

Sewage Ejection Pumps

Vertical Submerged Non-Clog Sewage Ejector Pumps for Industrial and Commercial Pumping

Weinman Type M-VS sewage ejection pumps are designed for industrial and commercial pumping of sewage, sludge and trash. The submerged sewage ejectors are built in a wide range of pump sizes for a variety of applications. Auxiliary equipment is offered to assure the right model for your particular installation.

Accessories

Float Switch Weinman Sewage Ejectors are furnished with Square D Type GG-2 float switch. It is mounted on an elevated stand and equipped with movable rod and copper float measuring 6 inches in diameter by 9 inches long. Float switch can be furnished with Water Tight Type DW or explosion Resisting Type DR enclosures at additional cost.

Rubber Bearings Cutless water lubricated bearings can be used where bearings are submerged or water or liquids can be piped for lubrication and loads and temperatures are not injurious to rubber.

Mechanical Alternator Weinman Duplex Pumps are generally furnished with Square D 9038 Type AG mechanical alternator in place of the two float switches. Alternator can be furnished with Water Tight Type AW or Explosion Resisting Type AR enclosures at additional cost.

High Water Alarm Apex Markco high water alarm model LLC-1H with switch only, switch and horn, or switch, horn and reset button and panel. Senses static head pressure between media with bellows mounted in NEMA 1 enclosure. Trips microswitch on 2-3" fluid rise with no moving parts in the fluid.

Heads to 100'
Flows to 800GPM



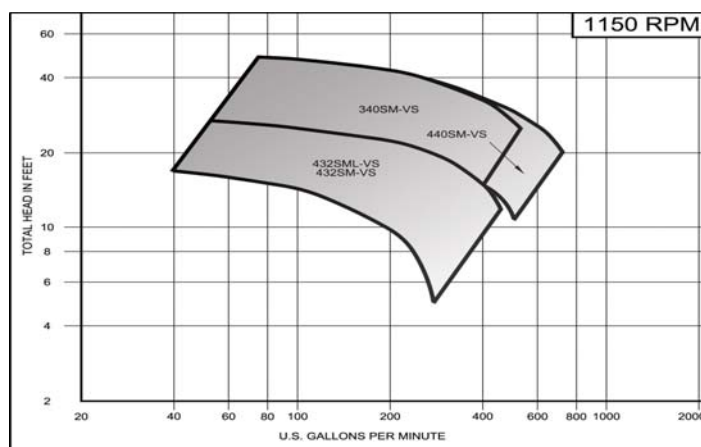
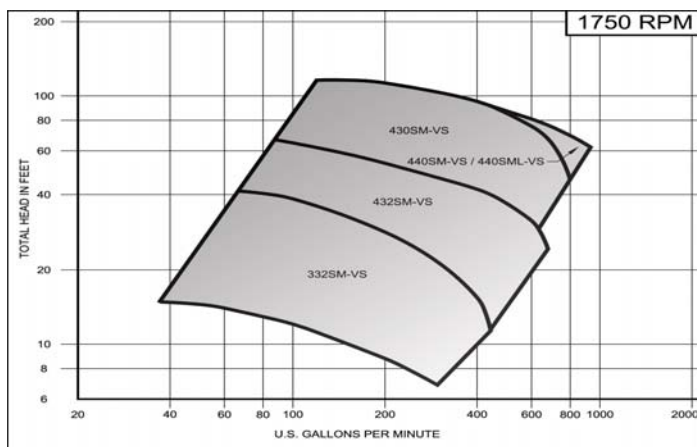

Flexible Coupling

- Woods coupling is standard. Using a flexible rubber sleeve instead of conventional spider, it absorbs misalignment and torsional shock. Requires no lubrication or adjustment once installed and aligned. Adjusting nut allows impeller clearance to be changed.

- One Piece** thrust collar and bearing cap seals out dirt and moisture, as well as transmitting the thrust load from the shaft to bearing.

- Grease Fittings and Lines** allow bearings to be lubricated from above.

- Packing Gland** prevents leakage of gases or liquid along shaft. Grease lubricated.

Drive Shaft

- Ground and polished steel or sufficient size to prevent whipping. Steel or optional stainless steel available.

Bottom Bearing

- Replaceable bronze grease lubricated bearing gives adequate support to impeller at all times. May be converted to optional "Graphitor" or rubber "Cutless" without special bearing housing.

Shaft Sleeve

- Renewable sleeve eliminates wear on shaft... reduces maintenance costs.

Impeller

- Conventional enclosed non-clog type, with repelling vanes on back shroud to prevent packing of solids behind impeller.

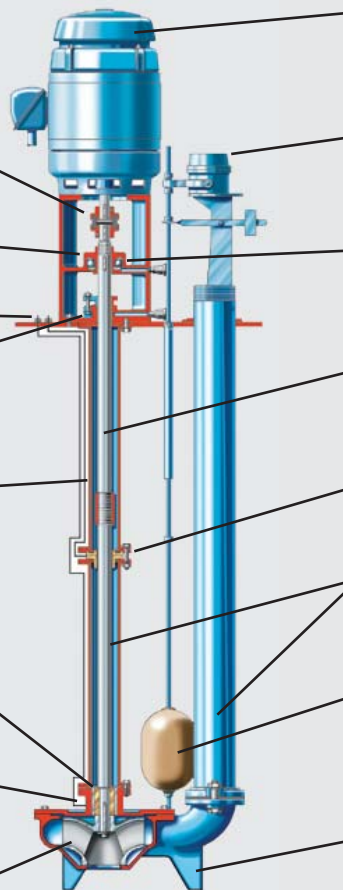

Motor

- NEMA type C flange-face motor mounts on driver pedestal without adapter or fittings.

Float Switch or Mechanical Alternator

- Heavy duty 2 pole switch or mechanical alternator is mounted on cast iron stand.

Thrust Bearing

- Grease lubricated angular contact-type ball thrust bearings carries both axial and radial loads.

Column and Shaft

- Lengths standardized to cover most sump depth requirements.

- Perfect Alignment** is provided by tenon fit between column and mating parts.

- Column** to discharge pipe spacing is in two sizes and allows for standardization of sizes and shape of basin covers.

Float

- Moveable copper float sides on non-corrosive float rod with adjustable stops. Eliminates need for high clearance over the float switch stand.

- Extra Heavy Duty Casing** of close-grained cast iron for long, corrosive-resistant underwater service.

CRANE®

PUMPS & SYSTEMS

A Crane Co. Company

Crane Pumps & Systems

420 Third Street
Piqua, Ohio 45356
(937) 778-8947
Fax (937) 773-7157

www.cranepumps.com

Crane Pumps & Systems Canada

83 West Drive
Brampton, Ont. Canada L6T 2J6
(905) 457-6223
Fax (905) 457-2650

Member of
Hydraulic
INDUSTRY

W800BRO - 6/10
Crane Pumps & Systems®
Printed in U.S.A.