



INSTALLATION, OPERATION & MAINTENANCE MANUAL

SK & SKX SERIES SHREDDER PUMPS Electric Submersible Pumps

Single Phase
115V & 230V
Three Phase
208V, 230V, 460V & 575V

CAST IRON

SINGLE PHASE

SK750C
SK1500C

THREE PHASE

SK08C SK55C
SK15C SK75C
SK22C SK110C
SK37C SK150C

316 STAINLESS STEEL

SINGLE PHASE

SKX750CSS
SKX1500CSS

THREE PHASE

SKX08CSS SKX55CSS
SKX15CSS SKX75CSS
SKX22CSS SKX110CSS
SKX37CSS SKX150CSS

Read this manual carefully before installing, operating or servicing these pump models. Observe all safety information. Failure to comply with instructions may result in personal injury and/or property damage. Please retain these instructions.

TABLE OF CONTENTS

INTRODUCTION.....	4
SAFETY	5
INSPECTION	6
PRE-INSTALLATION INSPECTION	6
OIL FILL QUANTITY/TYPE	7
PUMP INSTALLATION	7
POSITIONING THE PUMP	8
PUMP ROTATION	8
PUMP OPERATION.....	9
TYPICAL MUNICIPAL AND INDUSTRIAL WASTEWATER INTALLATION	9
MANUAL OPERATION	10
STOPPING	11
TYPICAL MUNICIPAL OR INDUSTRIAL WASTEWATER INSTALLATION	12
AUTOMATIC OPERATION	12
STOPPING.....	12
INTENDED METHODS OF CONNECTION.....	13
SINGLE PHASE WIRING INSTRUCTIONS	13
THREE PHASE WIRING INSTRUCTIONS.....	14
TROUBLE SHOOTING	15
PUMP WILL NOT RUN	15
PUMP RUNS BUT DOES NOT DELIVER RATED CAPACITY.....	15
SERVICING YOUR SUBMERSIBLE PUMP.....	15
MAINTAINING YOUR PUMP	16
CHANGING SEAL OIL	16
EXPLODED VIEW OF SK750C, SK1500C.....	17
EXPLODED VIEW OF SKX750CSS, SKX1500CSS.....	18
EXPLODED VIEW OF SK08C, SK15C.....	19
EXPLODED VIEW OF SKX08CSS, SKX15CSS.....	20
EXPLODED VIEW OF SK22C, SK37C.....	21
EXPLODED VIEW OF SKX22CSS, SKX37CSS.....	22
EXPLODED VIEW OF SK55C, SKX55CSS, SK75C, SKX75CSS.....	23
EXPLODED VIEW OF SK110C, SKX110CSS, SK150C, SKX150CSS	24
SK SERIES PARTS LIST.....	25
SKX SERIES PARTS LIST	27
SINGLE PHASE WIRING DIAGRAM 115V & 230V W/GOVERNOR SWITCH.....	29
MODELS SK750C, SKX750CSS, SK1500C, SKX1500C.....	29
THREE PHASE WIRING DIAGRAMS	30
208V.....	30
MODELS SK08C, SKX08CSS, SK15C, SKX15CSS, SK22C, SKX22CSS, SK37C, SKX37CSS, SK55C, SKX55CSS,	30
230V	31
MODELS SK08C, SKX08CSS, SK15C, SKX15CSS, SK22C, SKX22CSS, SK37C, SKX37CSS, SK55C, SKX55CSS, SKX75C, SKX75CSS, SK110C, SKX110CSS	31
460V.....	32
MODELS SK08C, SKX08CSS, SK15C, SKX15CSS, SK22C, SKX22CSS, SK37C, SKX37CSS, SK55C, SKX55CSS, SKX75C, SKX75CSS, SK110C, SKX110CSS, SK150C, SKX150CSS	32
575V.....	33
MODELS SK08C, SKX08CSS, SK15C, SKX15CSS, SK22C, SKX22CSS, SK37C, SKX37CSS, SK55C, SKX55CSS, SKX75C, SKX75CSS, SK110C, SKX110CSS, SK150C, SKX150CSS	33
SEAL MINDER®.....	34
WARRANTY AND LIMITATION OF LIABILITY.....	36
START-UP REPORT FORM.....	37
NOTES:.....	40



INTRODUCTION

This Installation, Operation and Maintenance manual provides important information on safety and the proper inspection, disassembly, assembly and testing of the BJM Pumps® SK & SKX Series submersible pump. This manual also contains information to optimize performance and longevity of your **BJM Pumps** submersible pump.

The submersible SK Series pumps are designed to pump wastewater and industrial wastewater that includes up to 10% by volume of solids. The SKX Series pumps are designed to pump corrosive liquids along with some solids in concentrations chemically compatible with 316SS and FKM. The SK & SKX Series pumps are not explosion-proof. They are not designed to pump volatile or flammable liquids.

Note: Consult chemical resistance chart for compatibility between pump materials and liquid before operating pump.

If you have any questions regarding the inspection, disassembly, and assembly or testing please contact your **BJM Pumps** distributor, or BJM Pumps, LLC.

BJM Pumps, LLC
123 Spencer Plain Rd.
Old Saybrook, CT 06475, USA

Phone: 877-256-7867
Phone: 860-399-5937
Fax: 860-399-7784

Information, including pump data sheets and performance curves, is also available on our web site: www.bjimpumps.com

For assistance with your electric power source, please contact a certified electrician.

Please pay attention to the following alert notifications. They are used to notify operators and maintenance personnel to pay special attention to procedures, to avoid causing damage to the equipment, and to avoid situations that could be dangerous to personnel.

NOTE: Instructions to aid in installation, operation, and maintenance or which clarify a procedure.

⚠ DANGER Immediate hazards that WILL result in severe personal injury or death. These instructions describe the procedure required and the injury which will result from failure to follow the procedure.

⚠ WARNING Hazards or unsafe practices that COULD result in severe personal injury or death. These instructions describe the procedure required, and the injury which could result from failure to follow the procedure.



⚠ CAUTION

Hazards or unsafe practices which COULD result in personal injury or product or property damage. These instructions describe the procedure required and the possible damage which could result from failure to follow the procedure.

SAFETY

Pump installations are seldom identical. Each installation and application can vary due to many different factors. It is the owner/service mechanics responsibility to repair, service, and test to ensure that the pump integrity is not compromised according to this manual.

⚠ WARNING

Risk of electric shock – this pump has not been investigated for use in swimming pool areas.

⚠ DANGER

Do not pump flammable, inflammable or volatile liquids. Death or serious injury will result.

⚠ WARNING

Before attempting to open or service the pump:

- 1) Familiarize yourself with this manual.
- 2) Unplug or disconnect the pump power cable to ensure that the pump will remain inoperative.
- 3) Allow the pump to cool if overheated.

⚠ WARNING

Do not operate the pump with a worn or damaged electric power cable. Death or serious injury could occur.

⚠ WARNING

Never attempt to alter the length or repair any power cable with a splice. The pump motor and pump motor and cable must be completely waterproof. Damage to the pump or personal injury may result from alterations.

⚠ WARNING

After the pump has been installed, make sure that the pump and all piping are secure before operation.

⚠ WARNING

Do not lift the pump by the power cable piping or discharge hose. Attach proper lifting equipment to the lifting handle (or lifting rings) fitted to the pump. Do not suspend the pump by the power cable.

⚠ WARNING

Obtain the services of a qualified electrician to troubleshoot, test and/or service the electrical components of this pump.



Pumps and related equipment must be installed and operated according to all national, local and industry standards.

INSPECTION

Review all safety information before servicing pump.

The following are recommended installation practices/procedures for the pump. If there are questions in regards to your specific application, contact your local **BJM Pumps** distributor or BJM Pumps, LLC.

PRE-INSTALLATION INSPECTION

- 1) Check the pump for damage that may have occurred during shipment.
- 2) Inspect the pump for any cracks, dents, damaged threads, etc.
- 3) Check power cord (and Seal Minder® cord, if installed) for any cuts or damage.
- 4) Check for, and tighten any hardware that appears loose.
- 5) Carefully read all tags, decals and markings on the pump.
- 6) Important: Always verify that the pump nameplate amps, voltage, phase, and HP ratings match your control panel and power supply.

Warranty does not cover damage caused by connecting pumps and controls to an incorrect power source (voltage/phase supply).

Record the model numbers and serial numbers from the pumps and control panel on the front of this instruction manual for future reference. Give it to the owner or affix it to the control panel when finished with the installation.

If anything appears to be abnormal, contact your **BJM Pumps** distributor or BJM Pumps, LLC. If damaged, the pump may need to be repaired before use. Do not install or use the pump until appropriate action has been taken.

Lubrication:

No additional lubrication is necessary. The shaft seal and bearings are fully lubricated from the factory. Seal oil should be checked once per year. See table: Oil Fill Quantity / Type.



OIL FILL QUANTITY/TYPE

OIL IN SEAL CHAMBER			
MODEL	U.S. FL. OZ.	CC.	TYPE OF OIL
SK750C	7.8	230	ISO 32 NSF Food Grade Mineral Oil
SK750C-3	7.8	230	ISO 32 NSF Food Grade Mineral Oil
SK1500C	7.8	230	ISO 32 NSF Food Grade Mineral Oil
SK08C	7.8	230	ISO 32 NSF Food Grade Mineral Oil
SK08C-3	7.8	230	ISO 32 NSF Food Grade Mineral Oil
SK15C	7.8	230	ISO 32 NSF Food Grade Mineral Oil
SK22C	10	296	ISO 32 NSF Food Grade Mineral Oil
SK37C	10	296	ISO 32 NSF Food Grade Mineral Oil
SK55C	84.5	2500	ISO 32 NSF Food Grade Mineral Oil
SK75C	84.5	2500	ISO 32 NSF Food Grade Mineral Oil
SK110C	87.9	2600	ISO 32 NSF Food Grade Mineral Oil
SK150C	87.9	2600	ISO 32 NSF Food Grade Mineral Oil

OIL IN SEAL CHAMBER			
MODEL	U.S. FL. OZ.	CC.	TYPE OF OIL
SKX750CSS	6.75	200	ISO 32 NSF Food Grade Mineral Oil
SKX750CSS-3	6.75	200	ISO 32 NSF Food Grade Mineral Oil
SKX1500CSS	6.75	200	ISO 32 NSF Food Grade Mineral Oil
SKX08CSS	6.75	200	ISO 32 NSF Food Grade Mineral Oil
SKX08CSS-3	6.75	200	ISO 32 NSF Food Grade Mineral Oil
SKX15CSS	6.75	200	ISO 32 NSF Food Grade Mineral Oil
SKX22CSS	12	355	ISO 32 NSF Food Grade Mineral Oil
SKX37CSS	12	355	ISO 32 NSF Food Grade Mineral Oil
SKX55CSS	84.5	2500	ISO 32 NSF Food Grade Mineral Oil
SKX75CSS	84.5	2500	ISO 32 NSF Food Grade Mineral Oil
SKX110CSS	87.9	2600	ISO 32 NSF Food Grade Mineral Oil
SKX150CSS	87.9	2600	ISO 32 NSF Food Grade Mineral Oil

Note: EPDM seals will use Propylene glycol instead of Shell FM32 oil

PUMP INSTALLATION

SK & SKX Series pumps have been evaluated for use with water or water based solutions with some solids. Please contact the manufacturer for additional information.

The Shredder pumps (1 and 2 HP) are not designed to pump unscreened solids which could contain matter such as bunched paper towels, feminine napkins, tampon applicators, etc. This type of debris can clog the pump & prevent it from operating properly. The **BJM Pumps** Shredder Pumps (7.5 HP and larger) are designed to handle unscreened sewage.



⚠ WARNING

Risk of electric shock. Pump models; SK750C, SK750C-3, SKX750CSS & SK750CSS-3 (115v) are supplied with a grounding conductor and grounding-type attachment plug. All 230V single phase pumps and all three phase pumps do not come with electric plug connectors. To reduce the risk of electric shock, be certain that it is connected only to a properly grounded, grounding-type receptacle.

Lifting:

Attach a rope or lifting chain (not included) to the handle (or lifting rings) on the top of the pump.

⚠ CAUTION

Do not lift the pump by the power cable or discharge hose/piping. Proper lifting equipment (rope/chain) must be used.

POSITIONING THE PUMP

BJM Pumps, SK & SKX Series pumps are designed to operate fully or partially submerged. Avoid running the pump dry for extended periods of time. Refer to data sheet for minimum submersion depth for your particular model. Data sheets can be obtained online at www.bjimpumps.com or by calling BJM Pumps, LLC at 860-399-5937. As a general rule, SK and SKX Series SIDE discharge pumps can pump down to a level above the suction screen. Pumping lower than screen will permit air to enter the pump and cavitate, lose prime or become air bound.

⚠ CAUTION

- Do not run pump dry.
- Pump liquid should not exceed a maximum temperature of 104°F.
- Never place the pump on loose or soft ground. The pump may sink, preventing water from reaching the impeller. Place on a solid surface or suspend the pump with a lifting rope/chain. The SK & SKX Series pumps are provided with a suction strainer to prevent large solids from clogging the impeller. Any spherical solids which pass through the strainer should pass through the pump.
- For maximum pumping capacity, use the proper size non-collapsible hose or rigid piping. A check valve may be installed after the discharge to prevent back flow when the pump is shut off.
- Take stand off of pump when using slide rail. Keep stand and reattach when transporting or handling the pump.

PUMP ROTATION

Two ways to check the correct pump rotation:

1. By looking at the impeller; the rotation of the impeller should be counter clockwise as shown in the picture below.



2. By looking from the top of the pump. Since the impeller cannot be seen, the best way to check the rotation is to check the kick back motion of the pump when the pump just starts. The kick back motion of the pump should be counter clockwise as shown in the picture below.

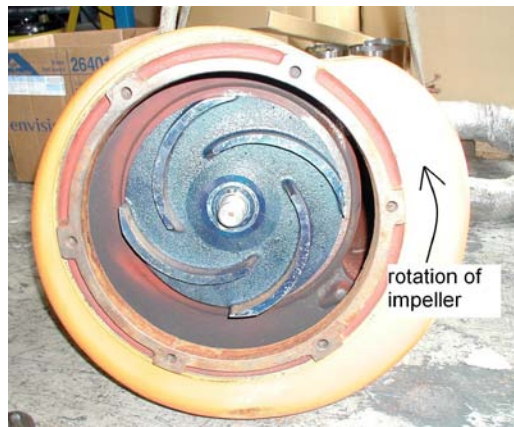

PUMP OPERATION

⚠ WARNING

This pump is designed to handle dirty water that contains some solids. It is not designed to pump volatile or flammable liquids. Do not attempt to pump any liquids which may damage the pump or endanger personnel as a result of pump failure.

⚠ DANGER

Do not operate this pump where explosive vapors or flammable material exist. Death or Serious injury will result.

TYPICAL MUNICIPAL AND INDUSTRIAL WASTEWATER INTALLATION

NOTE: Maximum recommended starts should not exceed 10 times per hour.



MANUAL OPERATION

All SK & SKX Models are provided with a 33' (10 m) power cord. **NEVER** splice the power cable due to safety and warranty considerations. Always keep the plug end dry.

Note: 230V, single phase and 208V, 230V, 460V & 575V three phase units do not have a plug and have to be provided separately.

⚠ WARNING

Do not alter the length or repair any power cable with a splice. The pump motor and cable must be completely waterproof. Damage to the pump or personal injury may result from alterations.

For manual operation: 115 volt: plug the power cable into any 115 volt grounded receptacle. 208, 230, 460 & 575 volt: Attach the proper plug, connect directly to the power source or control box. Check the direction of the rotation. Tilt the pump and start it. It should twist in the opposite direction of the arrow (on pump). It is recommended that a Ground Fault Interrupter (GFI) type receptacle (or equivalent) be used.

⚠ WARNING

Single phase pumps always use a three-prong grounded receptacle. It is recommended that a Ground Fault Interrupter (GFI) type receptacle (or equivalent) be used.

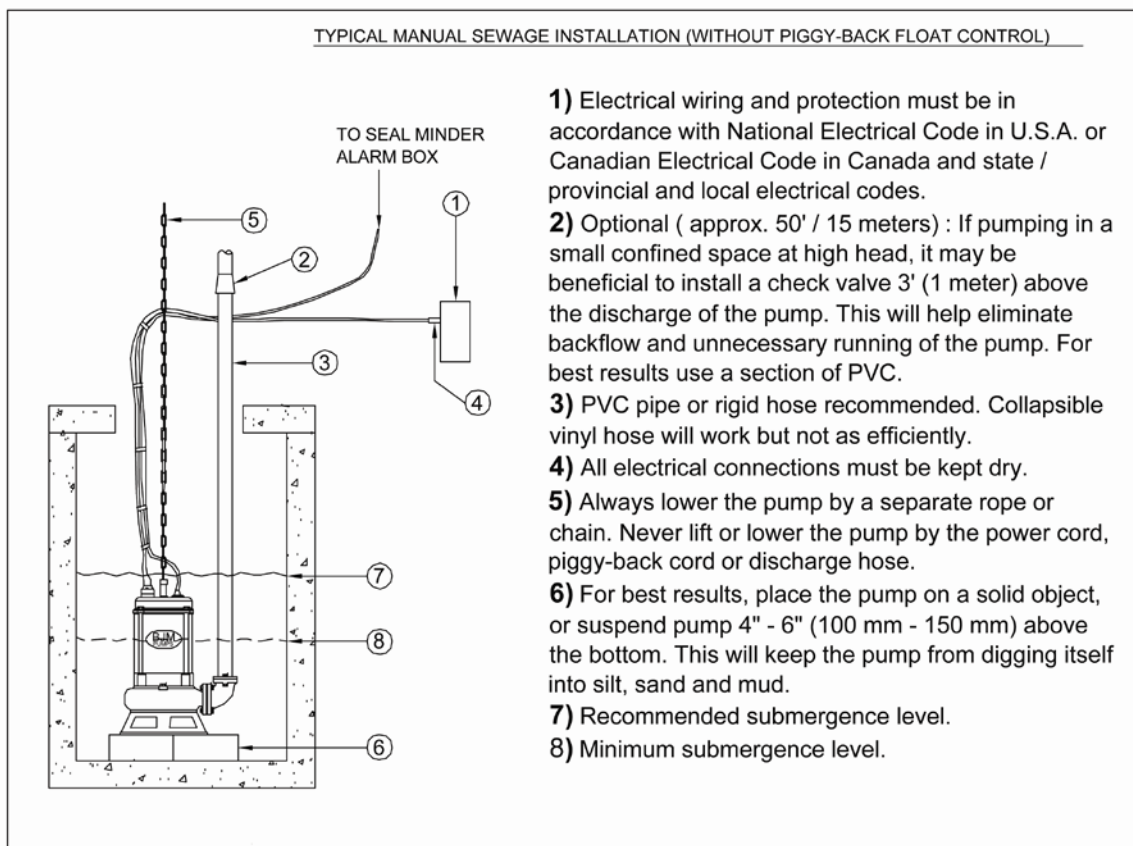



STOPPING

To stop the pump (manual and automatic mode), unplug it from the power source, turn off the breaker, or turn the power source off (generator).

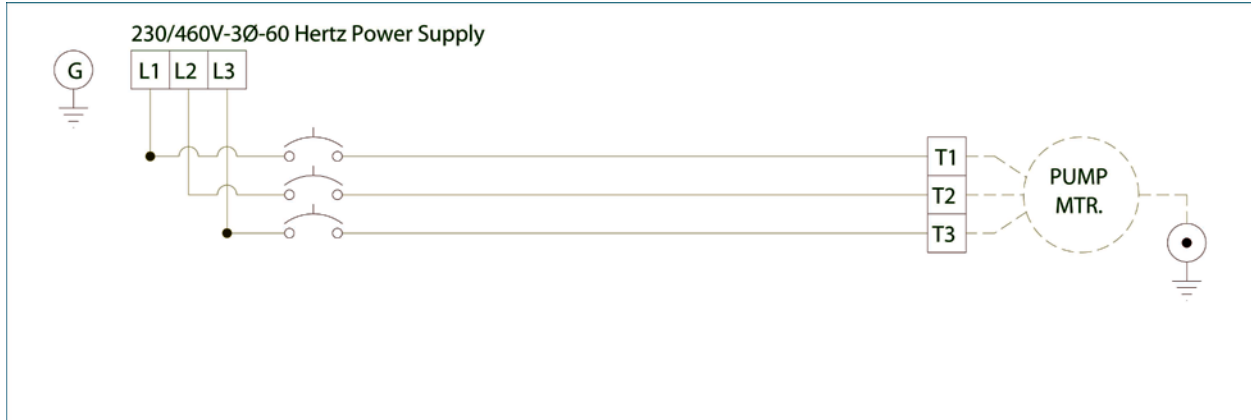

Typical 3 phase manual control 1

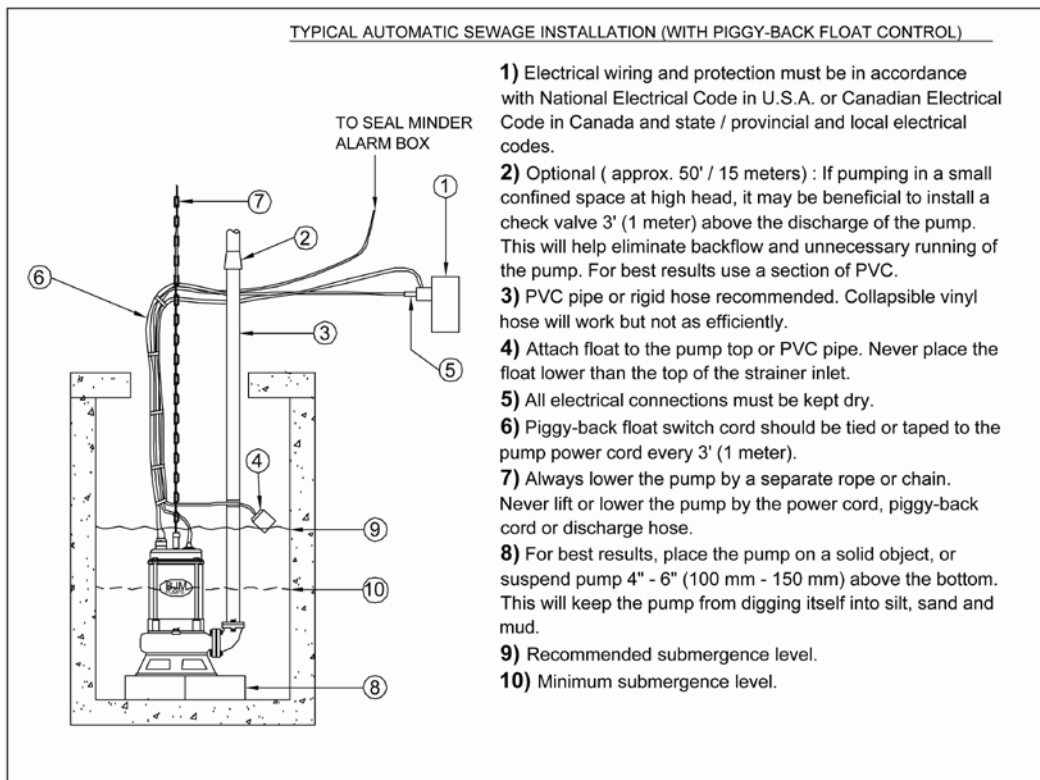

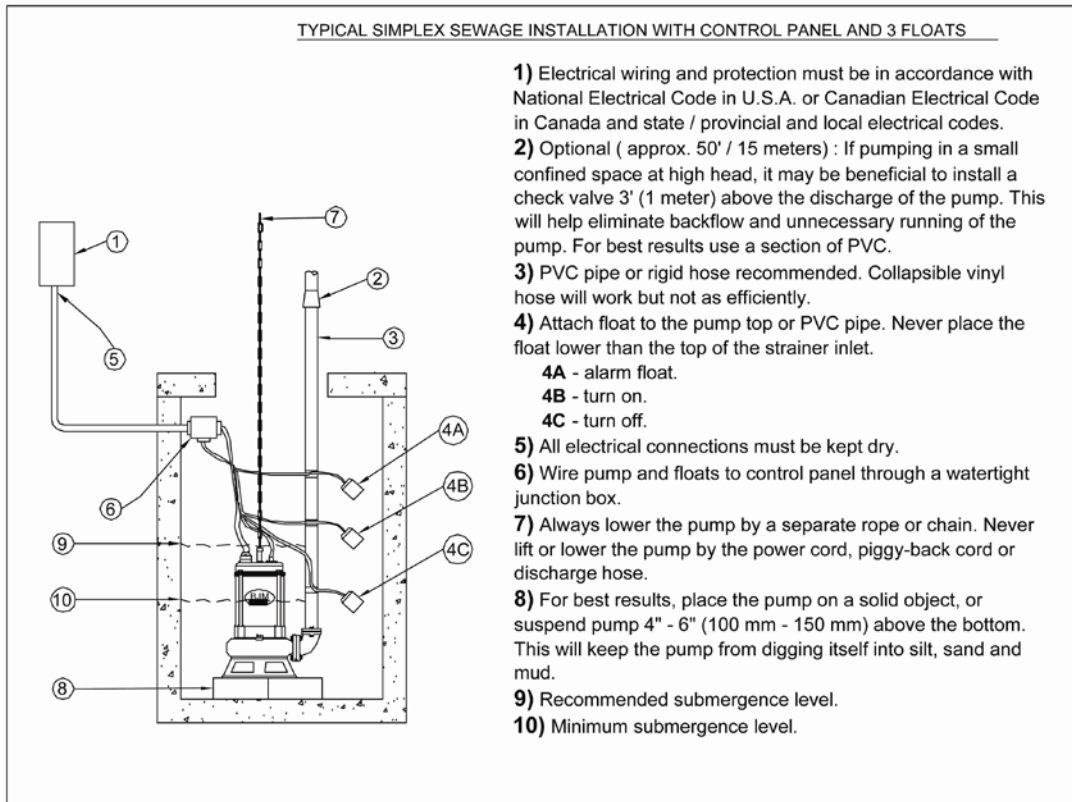

TYPICAL MUNICIPAL OR INDUSTRIAL WASTEWATER INSTALLATION

NOTE: Maximum recommended starts should not exceed 10 times per hour.

AUTOMATIC OPERATION

Float switches (wired into the pump motor or piggy-back style) are available from the factory as an option.

Note: 208V, 230V, 460V & 575V pumps do not have a plug installed.

Three phase pumps need a separate control box with float(s) for automatic operation.

STOPPING

To stop the pump (manual and automatic mode), unplug it from the power source, turn off the breaker, or turn the power source off (generator).

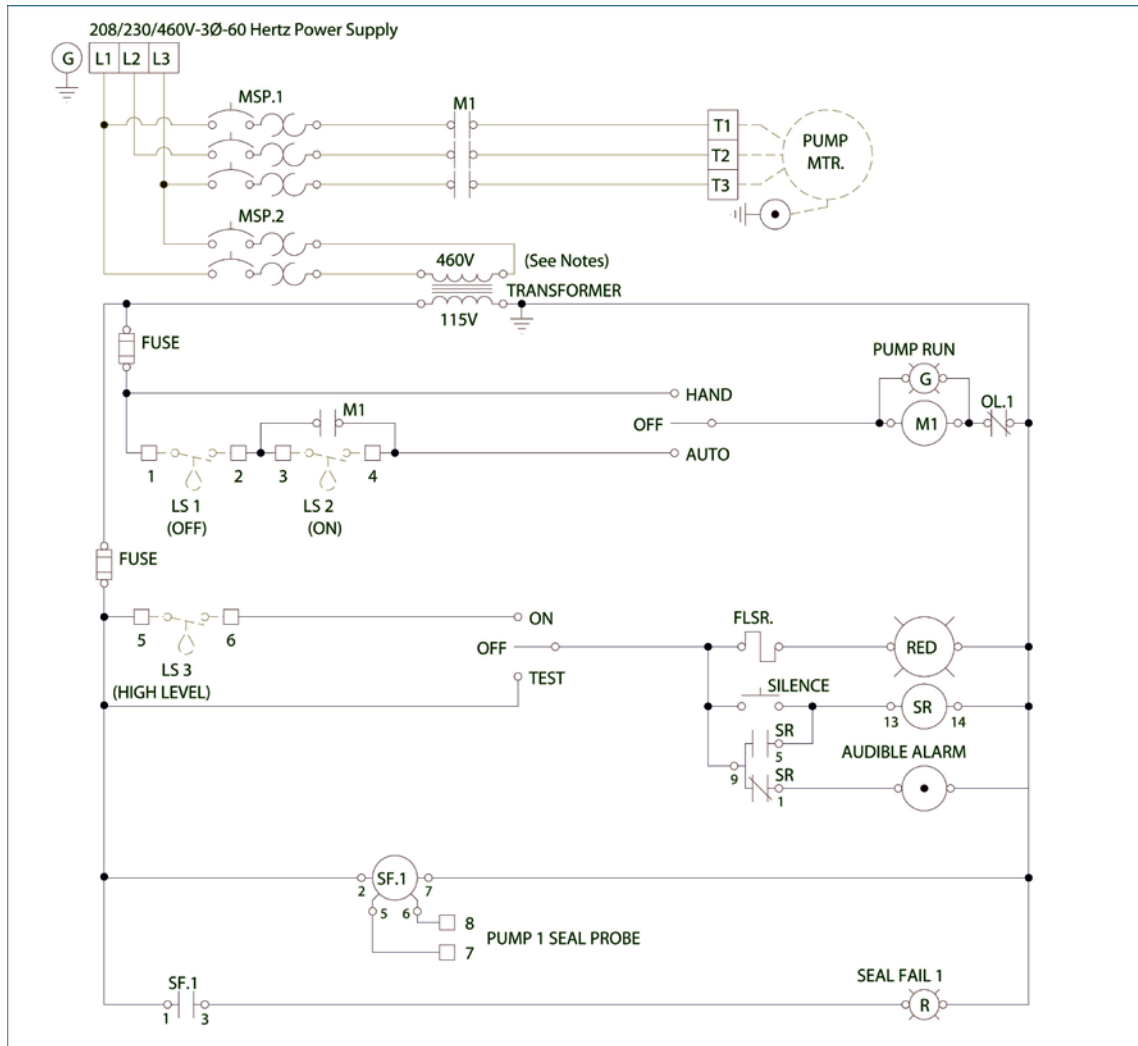

Typical 3 phase Auto Control 1

INTENDED METHODS OF CONNECTION



Use with approved motor control that matches motor input in full load amperes. "UTILISER UN DÉMARREUR APPROUVÉ CONVARIANT AU COURANT À PLEINE CHARGE DU MOTEUR."

BJM Pumps has been evaluated for use with water or water based solutions. Please contact the manufacturer for additional information.

SINGLE PHASE WIRING INSTRUCTIONS



FOR YOUR PROTECTION, ALWAYS DISCONNECT PUMP FROM ITS POWER SOURCE BEFORE HANDLING. Single phase pumps are supplied with a three prong grounded plug to help protect you against the possibility of electrical



shock. **DO NOT UNDER ANY CIRCUMSTANCES REMOVE THE GROUND PIN.** The three prong plug **must** be inserted into a mating three prong grounded receptacle. **IF** the installation does not have such a receptacle it must be changed to the proper type, wired and grounded in accordance with the National Electrical Code and all applicable local codes and ordinances.

⚠ CAUTION “Risk of electrical shock” Do not remove power supply cord and strain relief or connect conduit directly to the pump.

⚠ WARNING Installation and checking of electrical circuits and hardware should be performed by a qualified licensed electrician.

THREE PHASE WIRING INSTRUCTIONS

⚠ WARNING **FOR YOUR PROTECTION, ALWAYS DISCONNECT PUMP FROM ITS POWER SOURCE BEFORE HANDLING.**

⚠ CAUTION “Risk of electrical shock” Do not remove power supply cord and strain relief or connect conduit directly to the pump.

⚠ WARNING Installation and checking of electrical circuits and hardware should be performed by a qualified licensed electrician.

To automatically operate a non-automatic three phase pump, a control panel is required. Follow the instructions provided with the panel to wire the system. For automatic three phase pumps see automatic three phase wiring diagram.

Before installing a pump, check the pump rotation to insure that wiring has been connected properly to power source, and that the green lead of power cord (See wiring diagram), is connected to a valid ground, momentarily energize the pump, observing the directions of kick back due to starting torque. Rotation is correct if kick back is in the opposite direction of rotation arrow on the pump casing. If rotation is not correct, switching of any two power leads other than ground will provide the proper rotation.

⚠ DANGER **DO NOT PLACE HANDS IN PUMP SUCTION WHILE CHECKING MOTOR ROTATION. TO DO SO WILL CAUSE SEVERE PERSONAL INJURY.**

Three phase pumps have integral motor overload protection. It is recommended that all three phase pumps using a motor starting device also incorporate motor overload protection. Pumps **must** be installed in accordance with the National Electrical Code and all applicable local codes and ordinances. Pumps are not to be installed in locations classified as hazardous in accordance with National Electrical Code, ANSI/NFPA 70.



Connect pump to a junction box, outlet box, control box, enclosure with a wiring compartment that meets NEC and local codes. The provision for supply connection shall reduce the risk of water entry during temporary, limited submersion and shall comply with the applicable requirements of the Standard for Enclosures for Electrical Equipment, UL 50, or the standard for Metallic Outlet Boxes, UL 514A, and the standard for Motor-Operated Water Pumps. UL 778.

TROUBLE SHOOTING



Disconnect the power source to the pump BEFORE attempting any type of trouble shooting, service or repair.

PUMP WILL NOT RUN

1. Check power supply (fuses, breaker). Reset power.
2. Blocked impeller. Remove strainer, check and clean.
3. Defective cable or incorrect wiring.
4. Strainer clogged. Check and clean as necessary.
5. Float switch tangled/obstructed. Clean and free float switch from obstruction.
6. Float switch defective. Replace float switch.
7. Pump overheated or temperature of liquid exceeds pump operating temperature.

Warning: Pump will restart automatically when motor over-heat protection switch cools.

PUMP RUNS BUT DOES NOT DELIVER RATED CAPACITY

1. Discharge line clogged, restricted or hose kinked. Check discharge hose/pipe.
2. Worn impeller and/or suction cover. Inspect and replace as necessary.
3. Pump overloaded due to liquid pumped being too thick.
4. Pumping air. Check liquid level and position of pump.
5. Excessive voltage drops due to long cables.
6. Three phase only; pump running backwards, check rotation.

SERVICING YOUR SUBMERSIBLE PUMP

Pump should be disconnected from the electric power supply before proceeding to do any service or maintenance.

To service or repair your pump, please contact your local **BJM Pumps** distributor. Service should only be performed by a qualified electrician.



MAINTAINING YOUR PUMP

- Pump should be disconnected from the electric power supply before proceeding to do any service or maintenance.
- Pump should be inspected at regular intervals.
- More frequent inspections are required if the pump is used in a harsh environment.
- Preventative maintenance should be performed to reduce the chance of premature failure.
- Worn impellers and lip seals should be replaced.
- Cut or cracked power cords must be replaced. **(Never operate a pump with a cut, cracked or damaged power cord.)**
- Seal oil should be checked once per year.
- Maintenance should always be done when taking a pump out of service before storage.
- The impeller to suction cover clearance should be adjusted to between 0.01” to 0.02” for optimal cutting of the shredder. Shim kits are available if adjustment is required.
 - 1) Clean pump of dirt and other build up.
 - 2) Check condition of oil around the shaft seals.
 - 3) Check hydraulic parts: check for wear.
 - 4) Inspect power cable. Make sure that it is free of nicks or cuts.

CHANGING SEAL OIL

Changing the seal oil in the SK & SKX series pumps is very easy.

- 1) Make sure that the pump cable is disconnected from the power source.
- 2) Lay the pump down on its side.
- 3) Remove the screws that hold the bottom plate in place.
- 4) Remove bottom plate.
- 5) Remove screws holding the suction cover.
- 6) Remove the suction cover.
- 7) Remove the impeller.
- 8) Remove the inspection screw for the oil chamber (pos#50-08). Pour out a small sample of the oil. If it is milky white, or contains water, then the oil and possible, the mechanical seal, should be changed. If an oil change is needed.
- 9) Remove the screws that hold the oil chamber cover in place & remove the oil.
- 10) Replace the mechanical seal if necessary.
- 11) Replace the oil.
- 12) Assemble the pump.

EXPLODED VIEW OF SK750C, SK1500C

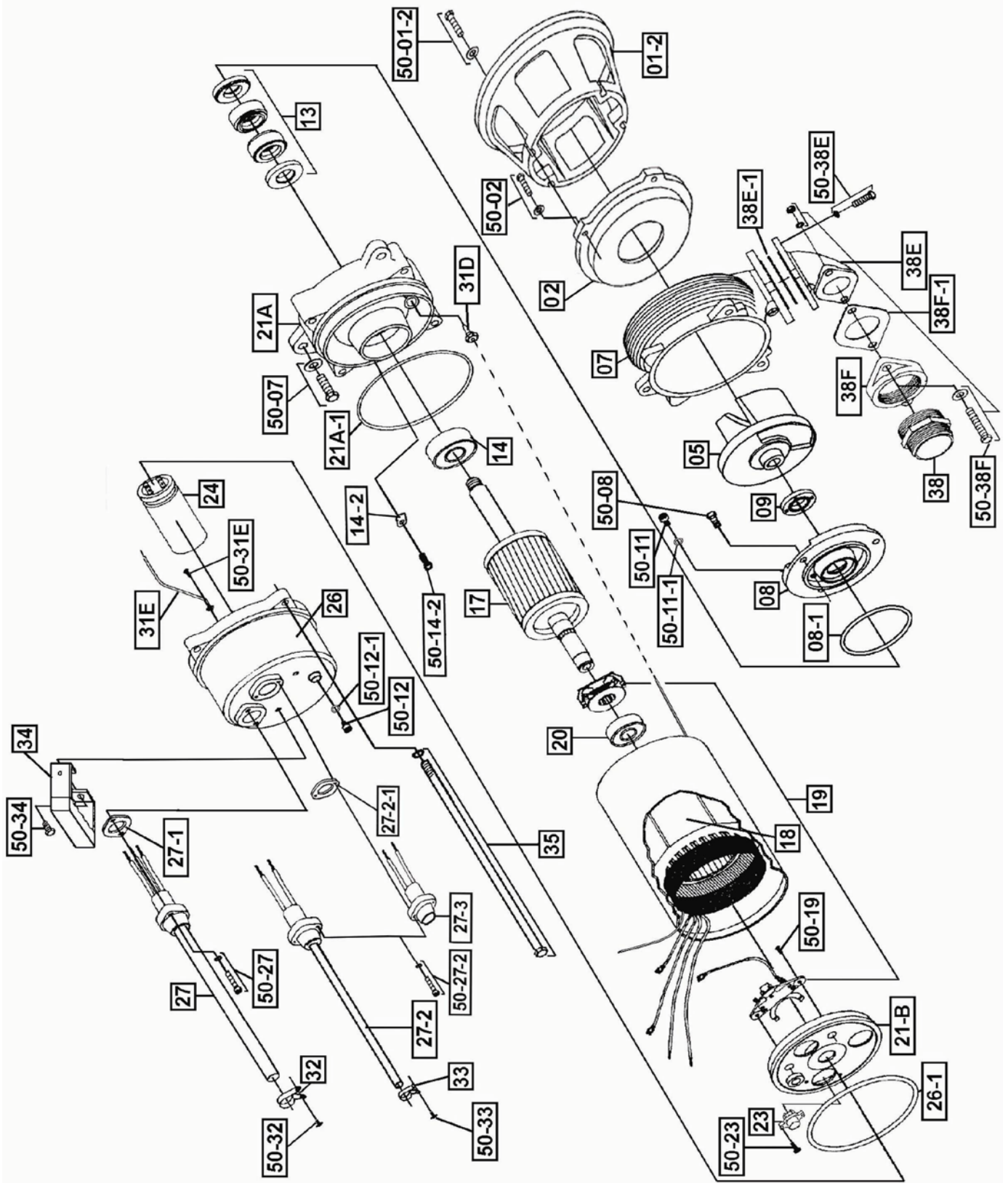



EXPLODED VIEW OF SKX750CSS, SKX1500CSS

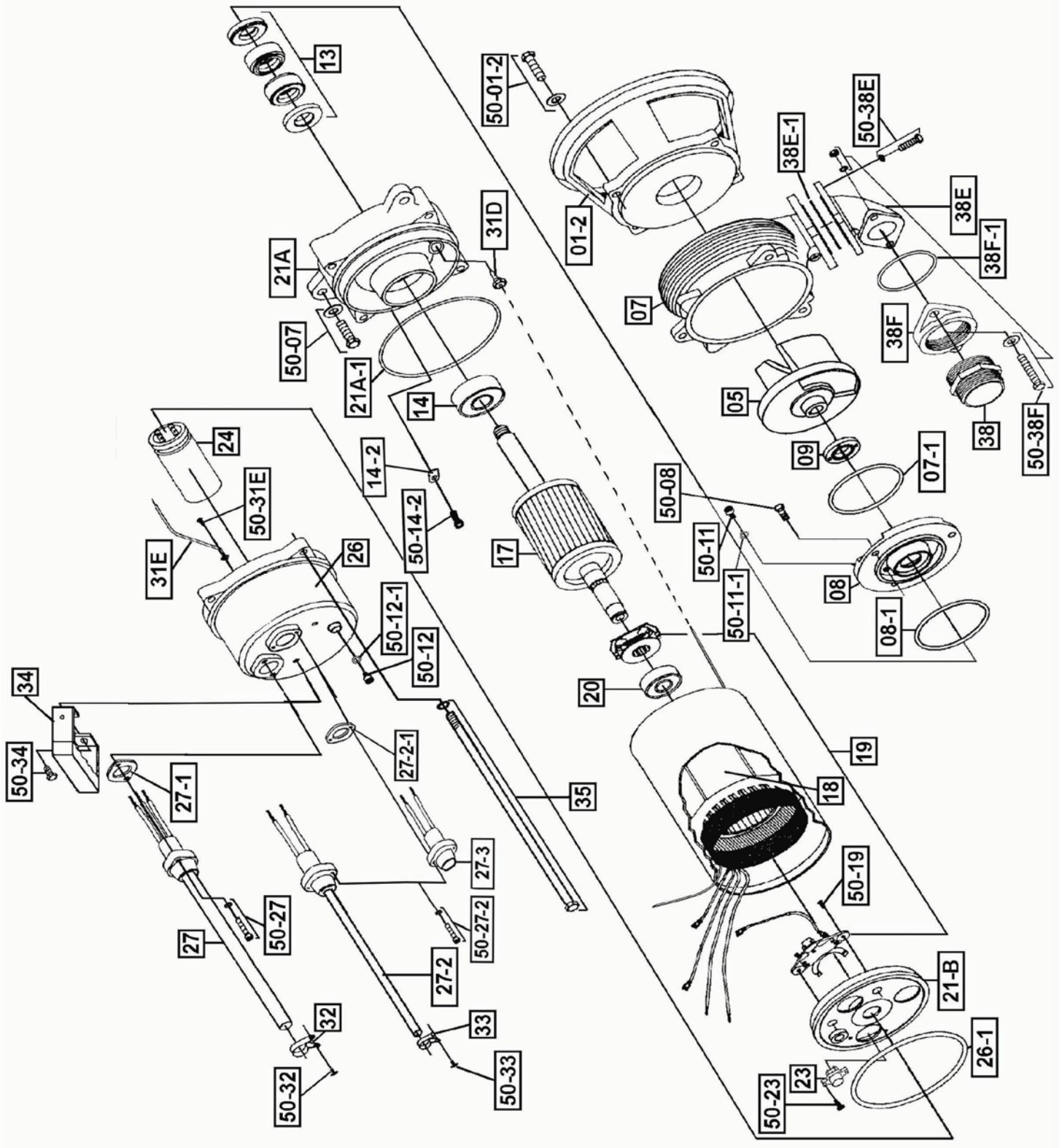

EXPLODED VIEW OF SK08C, SK15C

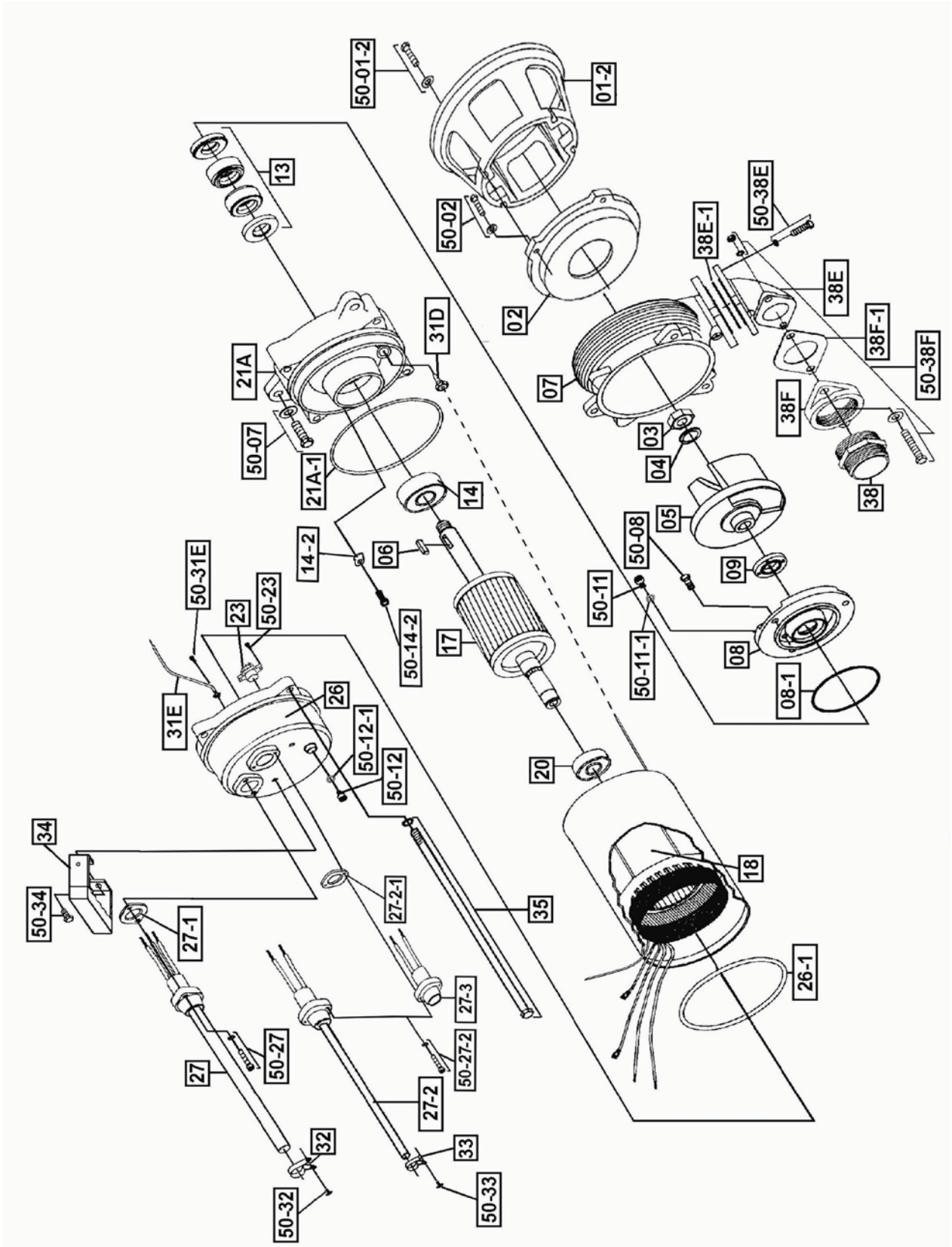



EXPLODED VIEW OF SKX08CSS, SKX15CSS

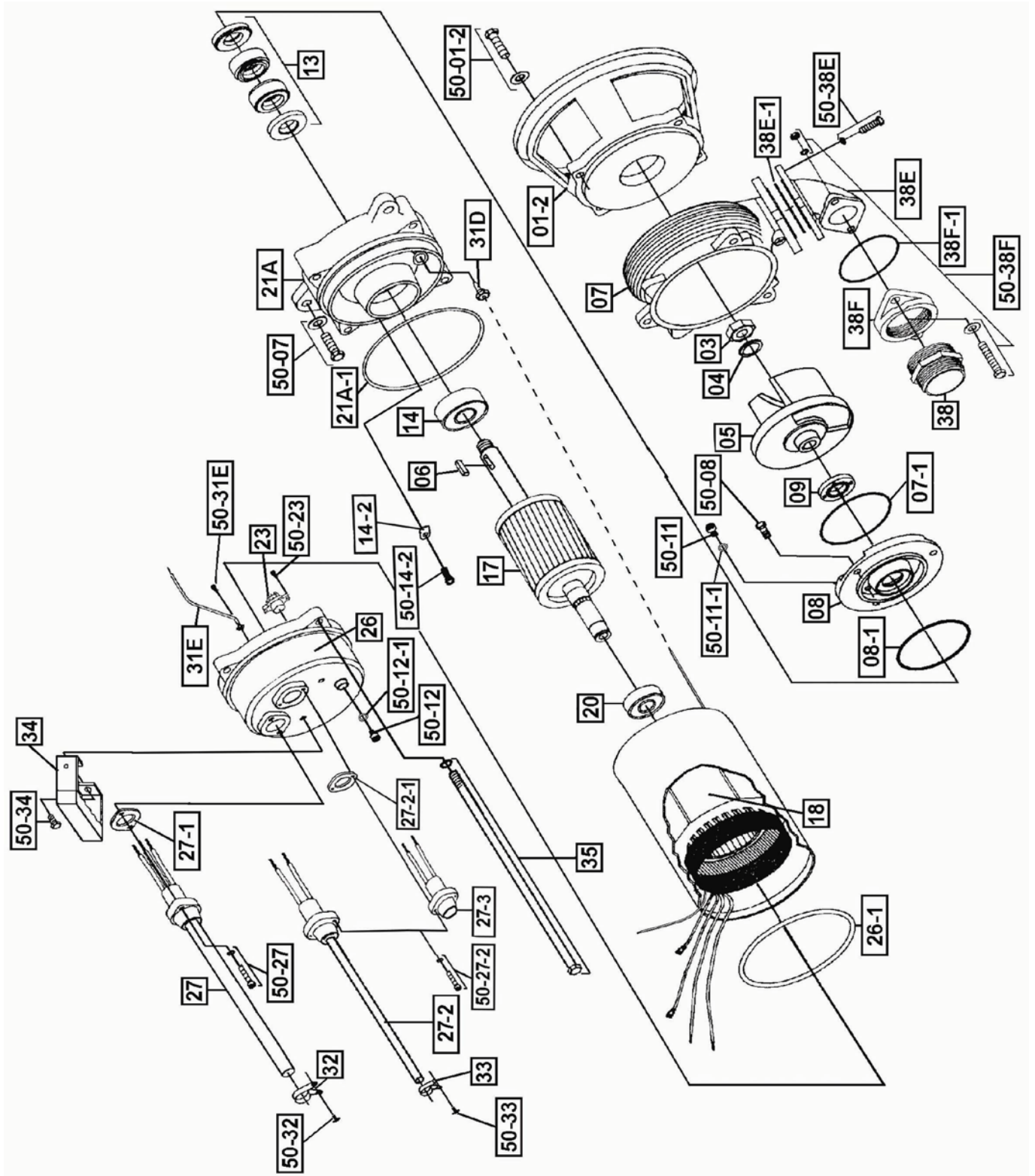



EXPLODED VIEW OF SK22C, SK37C

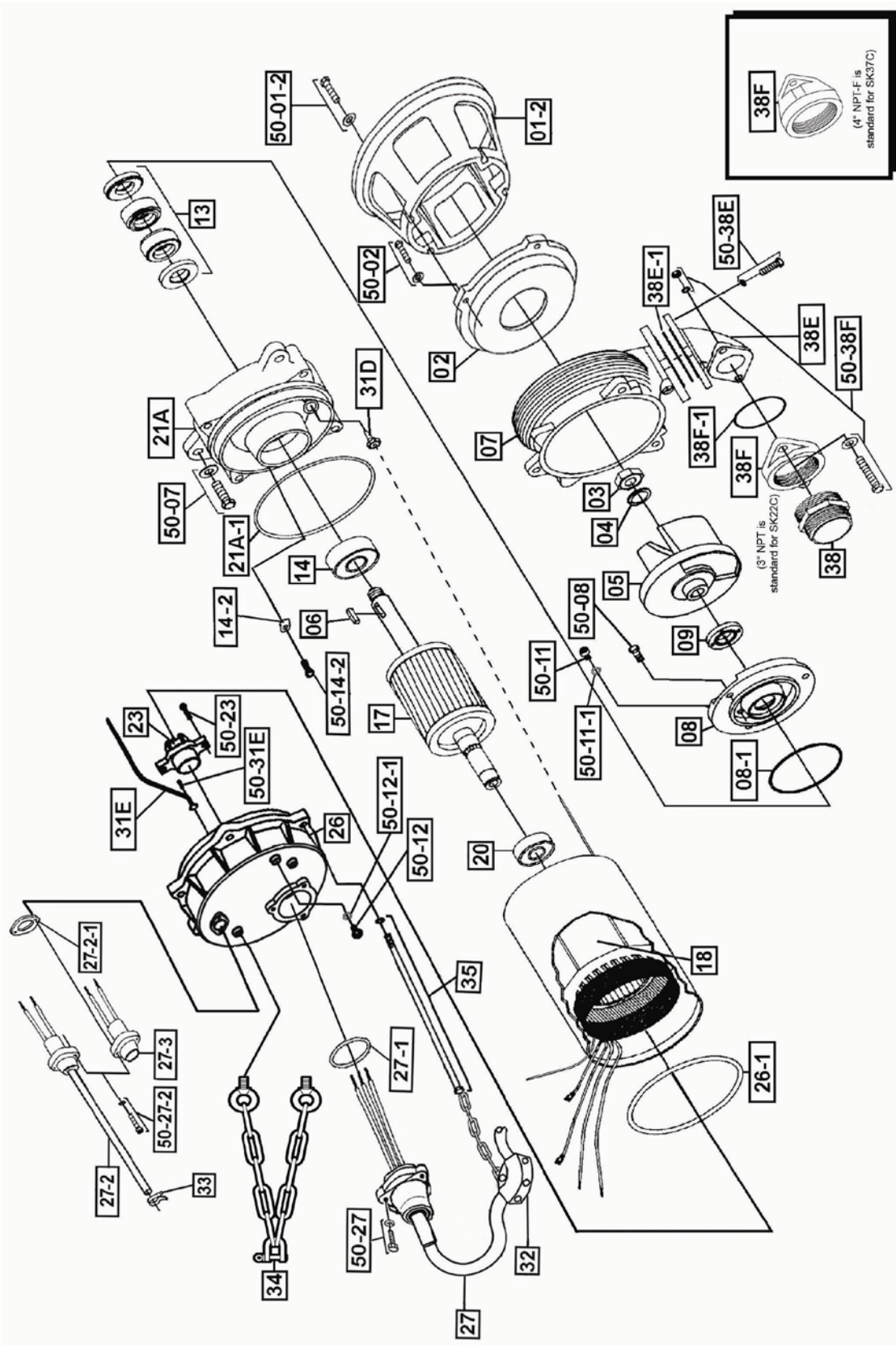



EXPLODED VIEW OF SKX22CSS, SKX37CSS

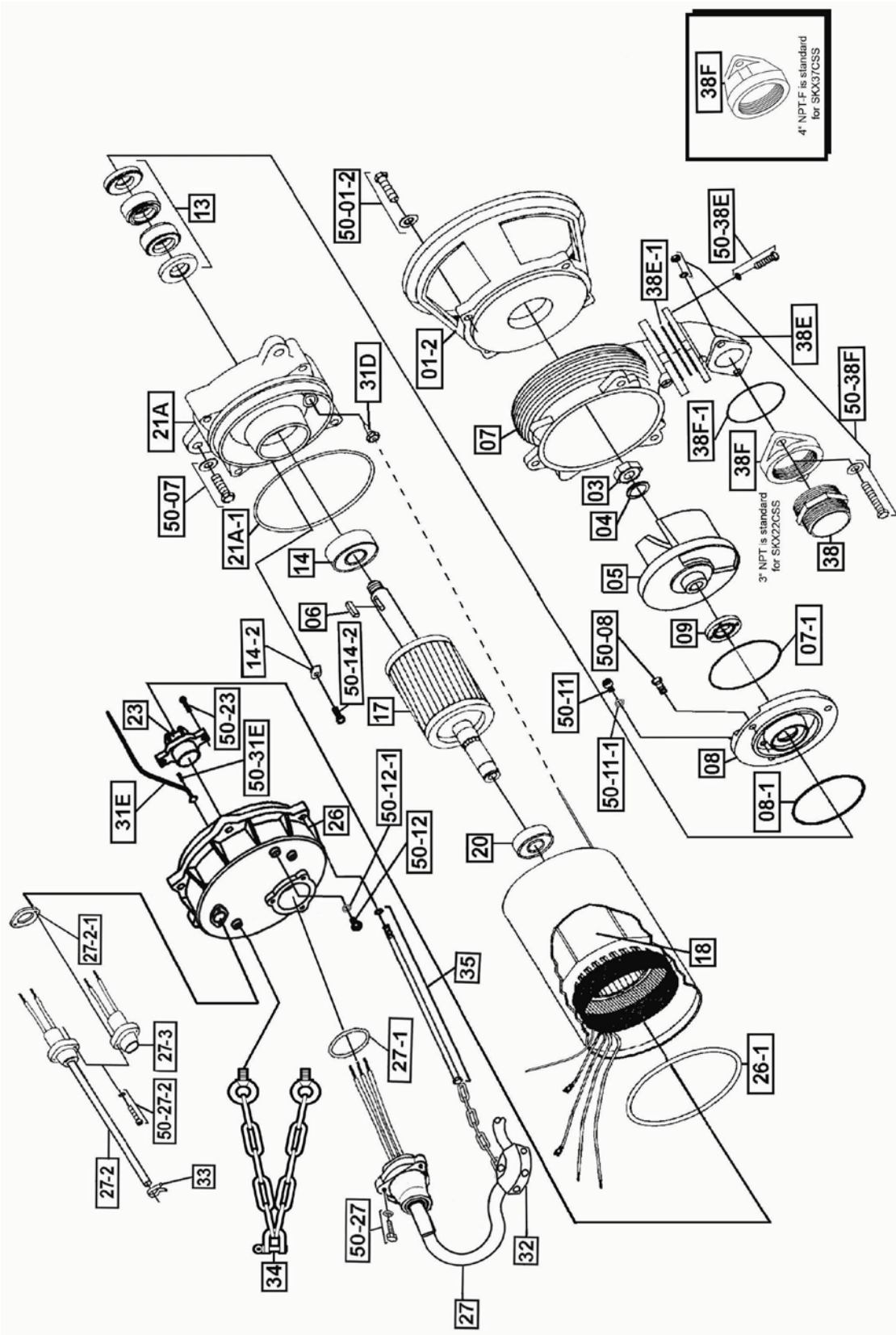



EXPLODED VIEW OF SK55C, SKX55CSS, SK75C, SKX75CSS

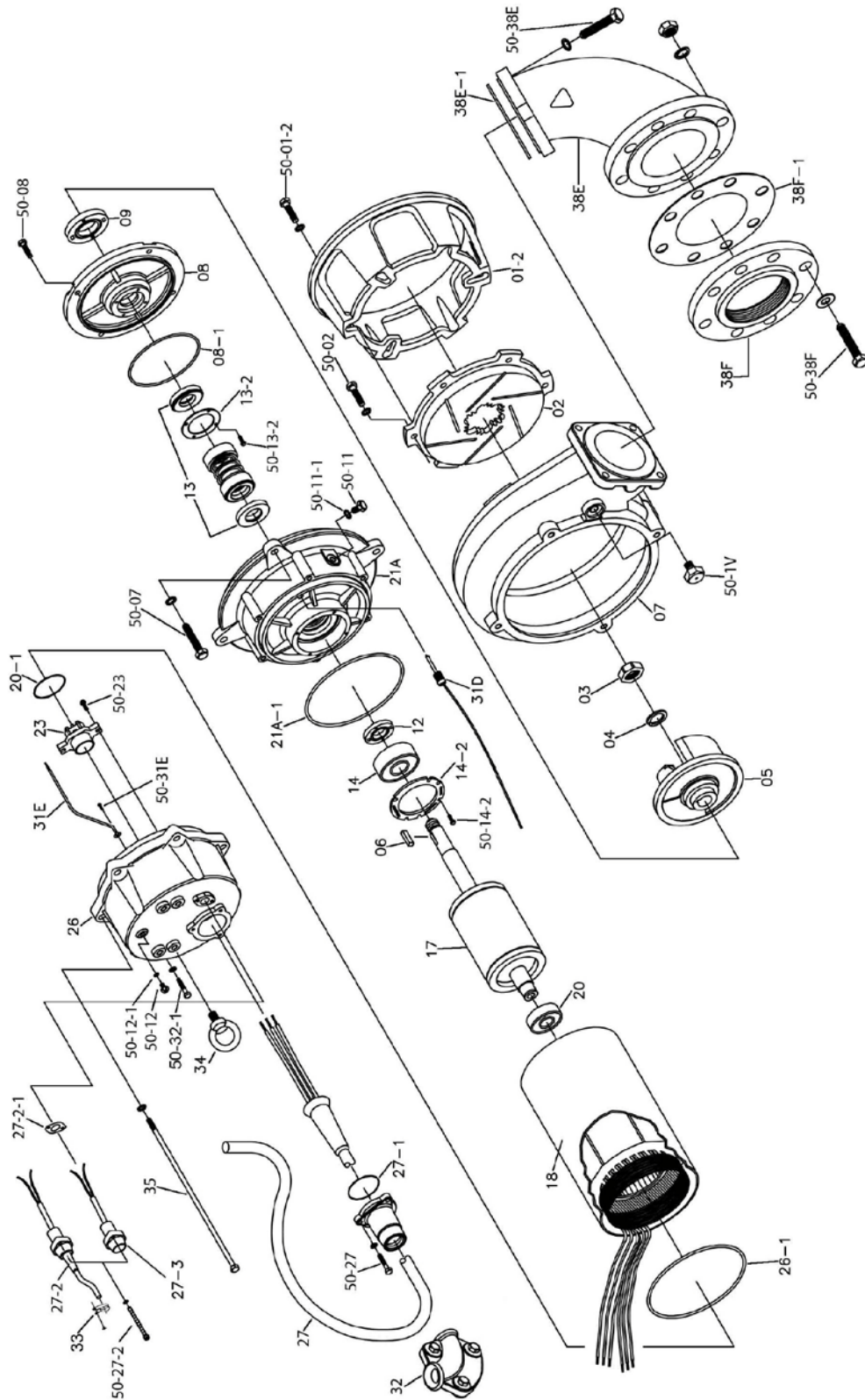



EXPLODED VIEW OF SK110C, SKX110CSS, SK150C, SKX150CSS

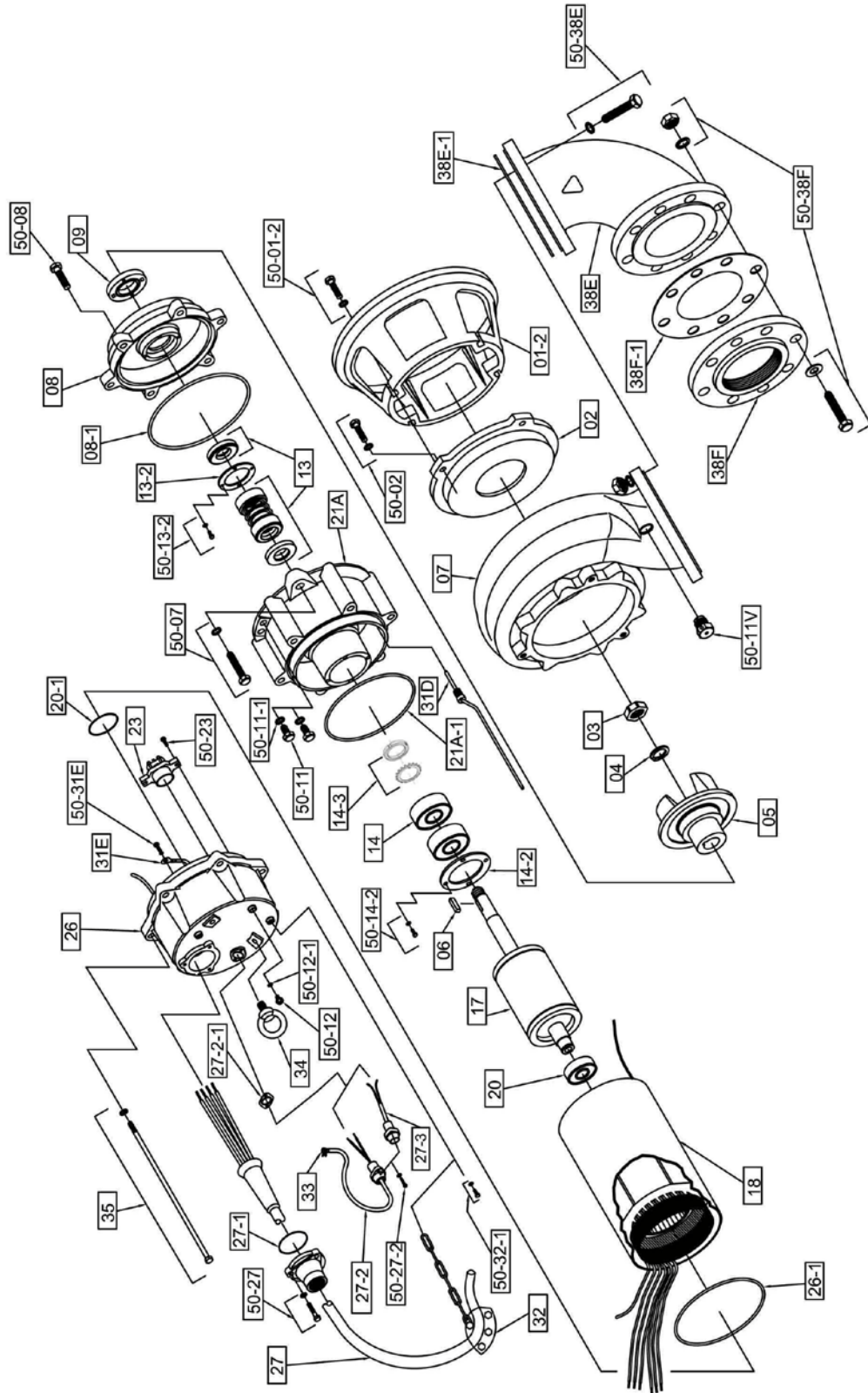

SK SERIES PARTS LIST

	Pump Model	SK750C	SK1500C	SK08C	SK15C	SK22C	SK37C	SK55C	SK75C	SK110C	SK150C
Pos. No.	Part Description	Part #	Part #	Part #	Part #	Part #	Part #	Part #	Part #	Part #	Part #
01-2	Stand Only	115B	120B	115B	120B	116B	119B	124C	124C	125C	125C
02	Suction Cover, Cast Iron	-	-	-	-	-	-	220	220	221	221
02	Suction Cover, Hi-Chrome	226A	227A	226A	227A	228A	229A	-	-	-	-
03	Impeller Nut	-	-	305	305	305	305	308C	308C	308C	308C
04	Impeller Washer	-	-	405C	405C	405C	405C	420	420	420	420
05	Impeller, Cast Iron	574C	575C	576C	577C	578C	579C	587C	588C	562C	563C
05	Impeller, Hi-Chrome	574A	575A	576A	577A	578A	579A	-	-	-	-
06	Impeller Key	-	-	602	602	602	602	610	610	610	613
07	Pump Housing	719C	718C	719C	718C	721C	723C	744C	744C	747C	747C
08	Oil Chamber Cover	810C	810C	810C	810C	822C	822C	823C	823C	825C	825C
08-1	O-Ring (Kit Only)	Kit	Kit	Kit	Kit	Kit	Kit	Kit	Kit	Kit	Kit
09	Lip Seal Buna-N	902C	902C	902C	902C	904C	904C	909C	909C	909C	909C
09	Lip Seal FKM (Optional)	903CV	903CV	903CV	903CV	905CV	905CV	914CV	914CV	914CV	914CV
09	Lip Seal EPDM (Optional)	903CE	903CE	903CE	903CE	905E	905E	912E	912E	912E	912E
12	Lip Seal for Lower Bearing	-	-	-	-	-	-	906C	906C	-	-
13	Mechanical Seal Buna-N	200215	200215	200215	200215	200302	200302	200308	200308	200308	200308
13	Mechanical Seal FKM (Optional)	200214	200214	200214	200214	200301	200301	200307	200307	200307	200307
13-2	Mechanical Seal Retainer	-	-	-	-	-	-	1377	1377	1377	1377
14	Lower Ball Bearing (* =Qty 2 Needed)	1401	1401	1401	1401	1402	1402	2012	2012	* 2012	* 2012
14-2	Lower Bearing Retainer	1453	1453	1453	1453	1453	1453	1454	1454	1455	1455
14-3	Lock Nut & Lock Washer	-	-	-	-	-	-	-	-	200424	200424
17	Rotor w/ Shaft 115/230V, 1PH	1705C	1706C	-	-	-	-	-	-	-	-
17	Rotor w/ Shaft, 3PH	-	-	1708C	1709C	1710C	1711C	1724C	1725C	1726C	1727C
18	Stator w/ Casing 115V, 1PH	200511	-	-	-	-	-	-	-	-	-
18	Stator w/ Casing 230V, 1PH	200570	200514	-	-	-	-	-	-	-	-
18	Stator w/ Casing 208V, 3PH	-	-	200524	200528	200532	200536	200669	-	-	-
18	Stator w/ Casing 230/460V, 3PH	-	-	200546	200550	200554	200558	200572	200576	200580	-
18	Stator w/ Casing 460V, 3PH	-	-	-	-	-	-	-	-	-	200584
18	Stator w/ Casing 575V, 3PH	-	-	200588	200592	200596	200600	200616	200622	200629	200636
19	Governor Switch w/Switch Plate	1904	1904	-	-	-	-	-	-	-	-
20	Upper Ball Bearing	2002	2002	2002	2002	2004	2004	2011	2011	2011	2011
20-1	O-Ring (Kit Only)	-	-	-	-	-	-	Kit	Kit	Kit	Kit
21A	Oil Chamber/Motor Housing	752C	752C	752C	752C	753C	753C	754C	754C	755C	755C
21A-1	O-Ring (Kit Only)	Kit	Kit	Kit	Kit	Kit	Kit	Kit	Kit	Kit	Kit
21B	Motor Cover Upper	2104	2104	-	-	-	-	-	-	-	-
23	Overload Protector 115V, 1PH	2306	-	-	-	-	-	-	-	-	-
23	Overload Protector 230V, 1PH	2314	2306	-	-	-	-	-	-	-	-
23	Overload Protector 208V, 3PH	-	-	2308A	2310A	2311A	2312A	2313	-	-	-
23	Overload Protector 230V, 3PH	-	-	2308A	2310A	2311A	2312A	2313	2315	2316A	-
23	Overload Protector 460V, 3PH	-	-	2309	2308B	2310B	2311B	2312B	2313	2316B	2316A
23	Overload Protector 575V, 3PH	-	-	2317	2309	2308B	2310B	2311B	2312B	2313	2316B
24	Capacitor 115V	2450	-	-	-	-	-	-	-	-	-
24	Capacitor 230V	2451	2469	-	-	-	-	-	-	-	-
26	Pump Top Cover (w/ Sensor Opening)	2651B	2651B	2670B	2670B	2671B	2671B	2673	2673	2674	2675
26-1	O-Ring Kit Only	Kit	Kit	Kit	Kit	Kit	Kit	Kit	Kit	Kit	Kit
27	Power Cable w/ Gland-115V, 1PH	2713	-	-	-	-	-	-	-	-	-

27	Power Cable w/ Gland- 230V,1PH, No Plug	2713B	2713B	-	-	-	-	-	-	-	-
	Pump Model	SK750C	SK1500C	SK08C	SK15C	SK22C	SK37C	SK55C	SK75C	SK110C	SK150C
Pos. No.	Part Description	Part #	Part #	Part #	Part #	Part #	Part #	Part #	Part #	Part #	Part #
27	Power Cable w/ Gland- 3PH	-	-	2722	2722	2725	2726	2731	2731	2727	2727
27-1	O-Ring Kit Only	Kit	Kit	Kit	Kit	Kit	Kit	Kit	Kit	Kit	Kit
27-2	Oil Sensor Cable	2736	2736	2736	2736	2736	2736	2736	2736	2736	2736
27-2-1	O-Ring Kit Only	Kit	Kit	Kit	Kit	Kit	Kit	Kit	Kit	Kit	Kit
27-3	Seal Minder Cap	2738	2738	2738	2738	2738	2738	2738	2738	2738	2738
31D	Oil Sensor w/Wire and Ring Term.	2330	2330	2330	2330	2330	2330	2330	2330	2330	2330
31E	Ground Wire w/Ring Term.	2776	2776	2776	2776	2776	2776	2776	2776	2776	2776
32	Power Cord Line Clip / Strain Relief	3200	3200	3200	3200	3208	3208	3210	3210	3211	3211
33	Oil Sensor Cord Line Clip	3203	3203	3203	3203	3203	3203	3203	3203	3203	3203
34	Handle / Chain Handle	3420	3420	3420	3420	3413	3413	-	-	-	-
34	Lifting Ring	-	-	-	-	-	-	3423	3423	3423	3423
35	Rod Bolts	4103	4104	4105	4106	4107	4108	4112	4113	4114	4115
38	Discharge Nipple 2"	3802	-	3802	-	-	-	-	-	-	-
38	Discharge Nipple 3"	-	3804	-	3804	3804	3804	-	-	-	-
38E	Discharge Elbow	3831	3820C	3831	3820C	3820C	3820C	3833	3833	3834C	3834C
38E-1	Gasket, Discharge Elbow Buna-N	4075	4072	4075	4072	4072	4072	4073	4073	4076	4076
38E-1	Gasket, Disch. Elbow FKM (Optional)	4075V	4072V	4075V	4072V	4072V	4072V	4073V	4073V	4076V	4076V
38F	Discharge Flange 2"	3822	-	3822	-	-	-	-	-	-	-
38F	Discharge Flange 3"	-	3810	-	3810	3810	3810	-	-	-	-
38F	Discharge Flange 4"	-	-	-	-	3816C	3816C	3835	3835	-	-
38F	Discharge Flange 6"	-	-	-	-	-	-	-	-	3812C	3812C
38F-1	Gasket, Discharge Flange Buna-N	4070	4071	4070	4071	4071	4071	4074	4074	4076	4076
38F-1	Gasket, Disch. Flange FKM (Optional)	4070V	4071V	4070V	4071V	4071V	4071V	4074V	4074V	4076V	4076V
50-01-2	Bolt for Strainer/Stand	5013	5013	5013	5013	5013	5013	5022	5022	5069	5069
50-02	Bolt for Suction Cover	5013	5013	5013	5013	5013	5013	5022	5022	5069	5069
50-07	Screw for Oil Chamber/Motor Housing	5013	5013	5013	5013	5013	5013	5061	5061	5070	5070
50-08	Screw for Oil Chamber Cover	5009	5009	5009	5009	5009	5009	5034	5034	5071	5071
50-11	Screw for Oil Fill	5008	5008	5008	5008	5008	5008	5051	5051	5072	5072
50-11-1	O-Ring (Kit Only)	Kit	Kit	Kit	Kit	Kit	Kit	Kit	Kit	Kit	Kit
50-11V	Air Release Valve	-	-	-	-	-	-	5080	5080	5080	5080
50-12	Screw for Pressure Check	5008	5008	5008	5008	5008	5008	5008	5008	5008	5008
50-12-1	O-Ring (Kit Only)	Kit	Kit	Kit	Kit	Kit	Kit	Kit	Kit	Kit	Kit
50-13-2	Screw for Seal Retainer	-	-	-	-	-	-	5001	5001	5001	5001
50-14-2	Screw for Brg. Retainer	5009	5009	5009	5009	5009	5009	5010	5010	5010	5010
50-19	Screw for Gov. Switch Plate	5002	5002	-	-	-	-	-	-	-	-
50-23	Screw for Overload	5028	5028	5028	5028	5028	5028	5028	5028	5028	5078
50-27	Screw for Power Cord	5004	5004	5004	5004	5004	5004	5034	5034	5034	5034
50-27-2	Screw for Oil Sensor Cord	5004	5004	5004	5004	5004	5004	5004	5004	5004	5004
50-31E	Screw for Ground Wire	5000	5000	5000	5000	5000	5000	5000	5000	5000	5000
50-32/50-33	Screw for Line Clip	5001	5001	5001	5001	-	-	-	-	-	-
50-32-1	Bolt for Power Cord Chain	-	-	-	-	-	-	5077	5077	5077	5077
50-34	Screw for Handle	5009	5009	5009	5009	-	-	-	-	-	-
50-38E	Bolt for Discharge Elbow	5041	5043	5041	5043	5043	5043	5066	5066	5068	5068
50-38F	Bolt for Discharge Flange	5083	5083	5083	5083	5083	5041	5067	5067	5068	5068
	O-Ring Kit - Buna N	4030C	4030C	4041C	4041C	4042C	4042C	4051C	4051C	4053C	4053C

SKX SERIES PARTS LIST

	Pump Model	SKX750C	SKX1500C	SKX08C	SKX15C	SKX22C	SKX37C	SKX55C	SKX75C	SKX110C	SKX150C
Pos. No.	Part Description	Part #	Part #	Part #	Part #	Part #	Part #	Part #	Part #	Part #	Part #
01-2	Stand Only	115PX	120PX	115PX	120PX	116PX	119PX	124CX	124CX	125CX	125CX
02	Suction Cover	-	-	-	-	-	-	220X	220X	221X	221X
03	Impeller Nut	-	-	305	305	305	305	308C	308C	308C	308C
04	Impeller Washer	-	-	405C	405C	405C	405C	420	420	420	420
05	Impeller	574CX	575BX	576CX	577CX	578CX	579CX	587CX	588CX	562CX	563CX
06	Impeller Key	-	-	602	602	602	602	610	610	610	613
07	Pump Housing	719PX	718PX	719PX	718PX	721PX	723PX	744CX	744CX	747CX	747CX
07-1	O-Ring (Kit Only)	Kit	Kit	Kit	Kit	Kit	Kit	-	-	-	-
08	Oil Chamber Cover	810PX	810PX	810PX	810PX	822PX	822PX	823CX	823CX	825CX	825CX
08-1	O-Ring (Kit Only)	Kit	Kit	Kit	Kit	Kit	Kit	Kit	Kit	Kit	Kit
09	Lip Seal FKM	903CV	903CV	903CV	903CV	905CV	905CV	914CV	914CV	914CV	914CV
09	Lip Seal Buna-N (Optional)	902C	902C	902C	902C	904C	904C	909C	909C	909C	909C
09	Lip Seal EPDM (Optional)	903CE	903CE	903CE	903CE	905E	905E	912E	912E	912E	912E
12	Lip Seal for Lower Bearing	-	-	-	-	-	-	906C	906C	-	-
13	Mechanical Seal FKM	200214	200214	200214	200214	200301	200301	200307	200307	200307	200307
13	Mechanical Seal Buna-N (Optional)	200215	200215	200215	200215	200302	200302	200308	200308	200308	200308
13-2	Mechanical Seal Retainer	-	-	-	-	-	-	1377	1377	1377	1377
14	Lower Ball Bearing (*=qty 2 Needed)	1401	1401	1401	1401	1402	1402	2012	2012	* 2012	* 2012
14-2	Lower Bearing Retainer	1453	1453	1453	1453	1453	1453	1454	1454	1455	1455
14-3	Lock Nut & Lock Washer									200424	200424
17	Rotor w/ Shaft 115/230V, 1PH	1705CX	1706CX	-	-	-	-	-	-	-	-
17	Rotor w/ Shaft, 3PH	-	-	1708CX	1709CX	1710CX	1711CX	1724CX	1725CX	1726CX	1727CX
18	Stator w/ Casing 115V, 1PH	200513	-	-	-	-	-	-	-	-	-
18	Stator w/ Casing 230V, 1PH	200571	200516	-	-	-	-	-	-	-	-
18	Stator w/ Casing 208V, 3PH	-	-	200526	200530	200534	200538	200671	-	-	-
18	Stator w/ Casing 230/460V,3PH	-	-	200548	200552	200556	200560	200574	200578	200582	-
18	Stator w/ Casing 460V,3PH	-	-	-	-	-	-	-	-	-	200586
18	Stator w/ Casing 575V, 3PH	-	-	200590	200594	200598	200602	200618	200624	200631	200638
19	Governor Switch w/Switch Plate	1904	1904	-	-	-	-	-	-	-	-
20	Upper Ball Bearing	2002	2002	2002	2002	2004	2004	2011	2011	2011	2011
20-1	O-Ring (Kit Only)	-	-	-	-	-	-	Kit	Kit	Kit	Kit
21A	Oil Chamber/Motor Housing	752PX	752PX	752PX	752PX	753PX	753PX	754CX	754CX	755CX	755CX
21A-1	O-Ring (Kit Only)	Kit	Kit	Kit	Kit	Kit	Kit	Kit	Kit	Kit	Kit
21B	Motor Cover Upper	2104	2104	-	-	-	-	-	-	-	-
23	Overload Protector 115V, 1PH	2306	-	-	-	-	-	-	-	-	-
23	Overload Protector 230V, 1PH	2314	2306	-	-	-	-	-	-	-	-
23	Overload Protector 208V, 3PH	-	-	2308A	2310A	2311A	2312A	2313	-	-	-
23	Overload Protector 230V, 3PH	-	-	2308A	2310A	2311A	2312A	2313	2315	2316A	-
23	Overload Protector 460V, 3PH	-	-	2309	2308B	2310B	2311B	2312B	2313	2316B	2316A
23	Overload Protector 575V, 3PH	-	-	2317	2309	2308B	2310B	2311B	2312B	2313	2316B
24	Capacitor 115V	2450	-	-	-	-	-	-	-	-	-
24	Capacitor 230V	2451	2469	-	-	-	-	-	-	-	-
26	Pump Top Cover (w/ Sensor opening)	2651BX	2651BX	2670BX	2670BX	2671PX	2671PX	2673X	2673X	2674X	2675X
26-1	O-Ring (Kit Only)	Kit	Kit	Kit	Kit	Kit	Kit	Kit	Kit	Kit	Kit
27	Power Cable w/ Gland- 115V, 1PH	2713X	-	-	-	-	-	-	-	-	-
27	Power Cable w/ Gland- 230V, 1 PH, No Plug	2713BX	2713BX	-	-	-	-	-	-	-	-
27	Power Cable w/ Gland- 3PH	-	-	2722X	2722X	2725X	2726X	2731X	2731X	2727X	2727X
27-1	O-Ring (Kit Only)	Kit	Kit	Kit	Kit	Kit	Kit	Kit	Kit	Kit	Kit

27-2	Oil Sensor Cable	2736X	2736X	2736X	2736X	2736X	2736X	2736X	2736X	2736X	2736X
	Pump Model	SKX750C	SKX1500C	SKX08C	SKX15C	SKX22C	SKX37C	SKX55C	SKX75C	SKX110C	SKX150C
Pos. No.	Part Description	Part #	Part #	Part #	Part #	Part #	Part #	Part #	Part #	Part #	Part #
27-2-1	O-Ring Kit Only	Kit	Kit	Kit	Kit	Kit	Kit	Kit	Kit	Kit	Kit
27-3	Seal Minder Cap	2738X	2738X	2738X	2738X	2738X	2738X	2738X	2738X	2738X	2738X
31D	Oil Sensor w/Wire and Ring Term.	2330	2330	2330	2330	2330	2330	2330	2330	2330	2330
31E	Ground Wire w/Ring Term.	2776	2776	2776	2776	2776	2776	2776	2776	2776	2776
32	Power Cord Line Clip / Strain Relief	3213	3213	3200	3200	3216	3217	3210	3210	3211	3211
33	Oil Sensor Cord Line Clip	3203	3203	3203	3203	3203	3203	3203	3203	3203	3203
34	Handle / Chain Handle	3420	3420	3420	3420	3413X	3413X	-	-	-	-
34	Lifting Ring	-	-	-	-	-	-	3423X	3423X	3423X	3423X
35	Rod Bolts	4118	4119	4120	4121	4122	4123	4112	4113	4114	4115
38	Discharge Nipple 2"	3802X	-	3802X	-	-	-	-	-	-	-
38	Discharge Nipple 3"	-	3804X	-	3804X	3804X	3804X	-	-	-	-
38E	Discharge Elbow	3831PX	3820PX	3831PX	3820PX	3820PX	3820PX	3833X	3833X	3834CX	3834CX
38E-1	O-Ring, Discharge Elbow FKM	5127V	5128V	5127V	5128V	5128V	5128V	-	-	-	-
38E-1	Gasket, Discharge Elbow FKM	-	-	-	-	-	-	4073V	4073V	4076V	4076V
38E-1	Gasket, Disch. Elbow Buna-N (Optional)	-	-	-	-	-	-	4073	4073	4076	4076
38F	Discharge Flange 2"	3822PX	-	3822PX	-	-	-	-	-	-	-
38F	Discharge Flange 3"	-	3810PX	-	3810PX	3810PX	3810PX	-	-	-	-
38F	Discharge flange 4"	-	-	-	-	3816PX	3816PX	3835X	3835X	-	-
38F	Discharge flange 6"	-	-	-	-	-	-	-	-	3812CX	3812CX
38F-1	O-Ring 2" Discharge Flange FKM	5125V	-	5125V	-	-	-	-	-	-	-
38F-1	O-Ring, 3" Discharge Flange FKM	-	5126V	-	5126V	5126V	5126V	-	-	-	-
38F-1	O-Ring, 4" Discharge Flange FKM	-	-	-	-	5129V	5129V	-	-	-	-
38F-1	Gasket, 4" Discharge Flange FKM	-	-	-	-	-	-	4074V	4074V	-	-
38F-1	Gasket, 6" Discharge Flange FKM	-	-	-	-	-	-	-	-	4076V	4076V
38F-1	Gasket, 4" Disch. Flange Buna-N (Optional)	-	-	-	-	-	-	4074	4074	-	-
38F-1	Gasket, 6" Disch. Flange Buna-N (Optional)	-	-	-	-	-	-	-	-	4076	4076
50-01-2	Bolt for Strainer/Stand	5013	5013	5013	5013	5013	5013	5022	5022	5069	5069
50-02	Bolt for Suction Cover	-	-	-	-	-	-	5022	5022	5069	5069
50-07	Screw for Oil Chamber/Motor Housing	5097	5097	5097	5097	5097	5097	5061	5061	5070	5070
50-08	Screw for Oil Chamber Cover	5009	5009	5009	5009	5009	5009	5034	5034	5071	5071
50-11	Screw for Oil Fill	5008	5008	5008	5008	5008	5008	5051	5051	5072	5072
50-11-1	O-Ring (Kit Only)	Kit	Kit	Kit	Kit	Kit	Kit	Kit	Kit	Kit	Kit
50-11V	Air Release Valve	-	-	-	-	-	-	5080	5080	5080	5080
50-12	Screw for Pressure Check	5008	5008	5008	5008	5008	5008	5008	5008	5008	5008
50-12-1	O-Ring (Kit Only)	Kit	Kit	Kit	Kit	Kit	Kit	Kit	Kit	Kit	Kit
50-13-2	Screw for Seal Retainer	-	-	-	-	-	-	5001	5001	5001	5001
50-14-2	Screw for Bearing Retainer Plate	5009	5009	5009	5009	5009	5009	5010	5010	5010	5010
50-19	Screw for Gov. Switch Plate	5002	5002	-	-	-	-	-	-	-	-
50-23	Screw for Overload	5028	5028	5028	5028	5028	5028	5028	5028	5028	5078
50-27	Screw for Power Cord	5095	5095	5095	5095	5034	5034	5034	5034	5034	5034
50-27-2	Screw for Sensor Cord	5095	5095	5095	5095	5095	5095	5095	5095	5095	5095
50-31E	Screw for Ground Wire	5000	5000	5000	5000	5000	5000	5000	5000	5000	5000
50-32/50-33	Screw for Line Clip	5001	5001	5001	5001	-	-	-	-	-	-
50-32-1	Bolt for Power Cord Strain Relief Chain	-	-	-	-	-	-	5077	5077	5077	5077
50-34	Screw for Handle	5009	5009	5009	5009	-	-	-	-	-	-
50-38E	Bolt for Discharge Elbow	5093	5061	5093	5061	5061	5061	5066	5066	5068	5068
50-38F	Bolt for Discharge Flange	5014	5093	5014	5093	5093	5093	5067	5067	5068	5068
	O-Ring Kit - FKM	4031PV	4031PV	4046PV	4046PV	4044PV	4044PV	4052CV	4052CV	4054CV	4054CV
	O-Ring Kit - Buna-N (Optional)	-	-	-	-	-	-	4051C	4051C	4053C	4053C

SINGLE PHASE WIRING DIAGRAM 115V & 230V W/GOVERNOR SWITCH

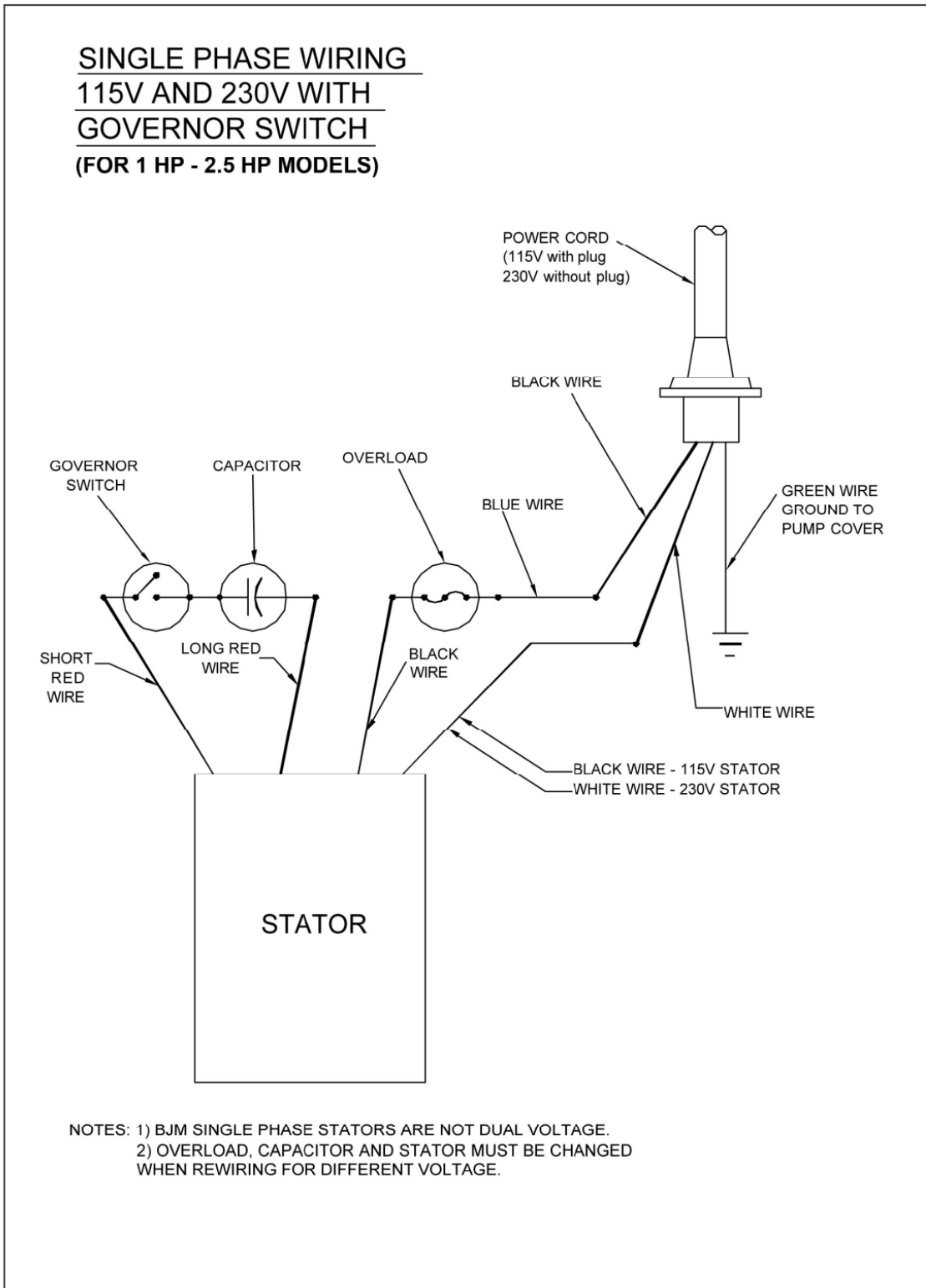

MODELS SK750C, SKX750CSS, SK1500C, SKX1500C

THREE PHASE WIRING DIAGRAMS

208V



WIRING DIAGRAM THREE PHASE 208V

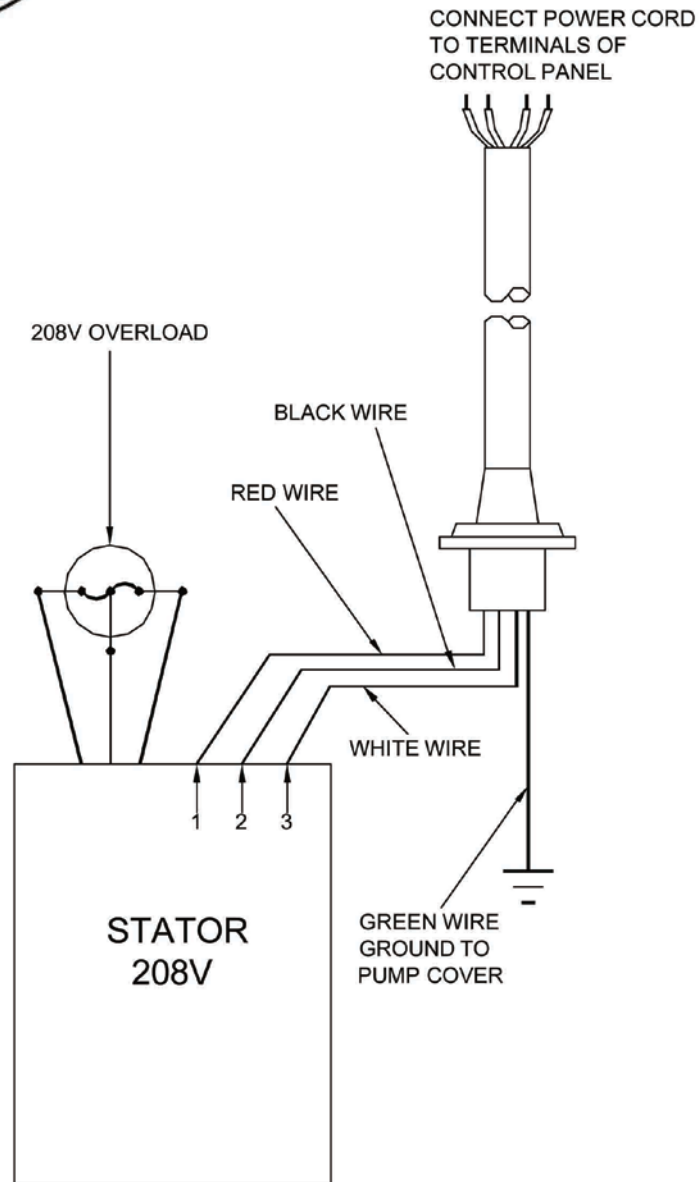

NOTE: 208V STATORS ARE SINGLE VOLTAGE STATORS AND HAVE 6 WIRE LEADS.

BJM Pumps, LLC - 123 Spencer Plain Road, Old Saybrook, CT 06475 - Phone:860-399-5937 - Fax:860-399-7784

REVISION 4/28/2006

Page 1 of 1

SPECIFICATIONS SUBJECT TO CHANGE WITHOUT NOTICE

MODELS SK08C, SKX08CSS, SK15C, SKX15CSS, SK22C, SKX22CSS, SK37C, SKX37CSS, SK55C, SKX55CSS,

230V



WIRING DIAGRAM
THREE PHASE 230V

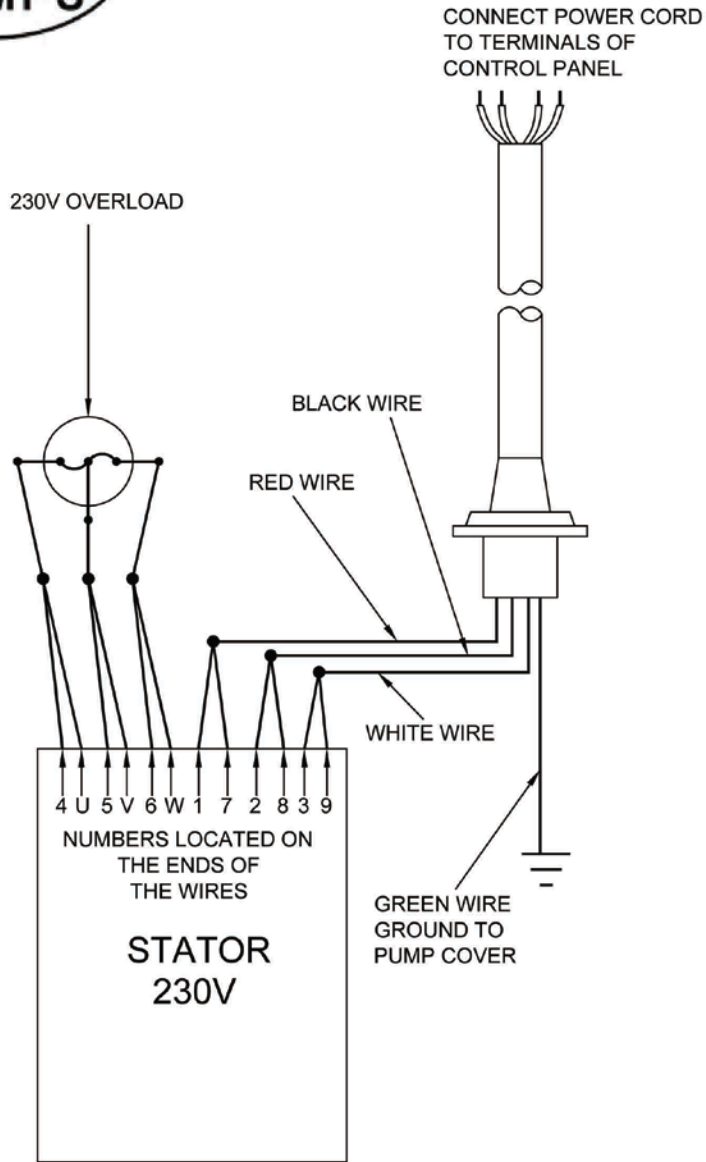

NOTE: OVERLOAD MUST BE CHANGED WHEN REWIRING FOR DIFFERENT VOLTAGE.

BJM Pumps, LLC - 123 Spencer Plain Road, Old Saybrook, CT 06475 - Phone:860-399-5937 - Fax:860-399-7784

REVISION 6/11/2004

Page 1 of 1

SPECIFICATIONS SUBJECT TO CHANGE WITHOUT NOTICE

MODELS SK08C, SKX08CSS, SK15C, SKX15CSS, SK22C, SKX22CSS, SK37C, SKX37CSS, SK55C, SKX55CSS, SKX75C, SKX75CSS, SK110C, SKX110CSS

460V



WIRING DIAGRAM
THREE PHASE 460V

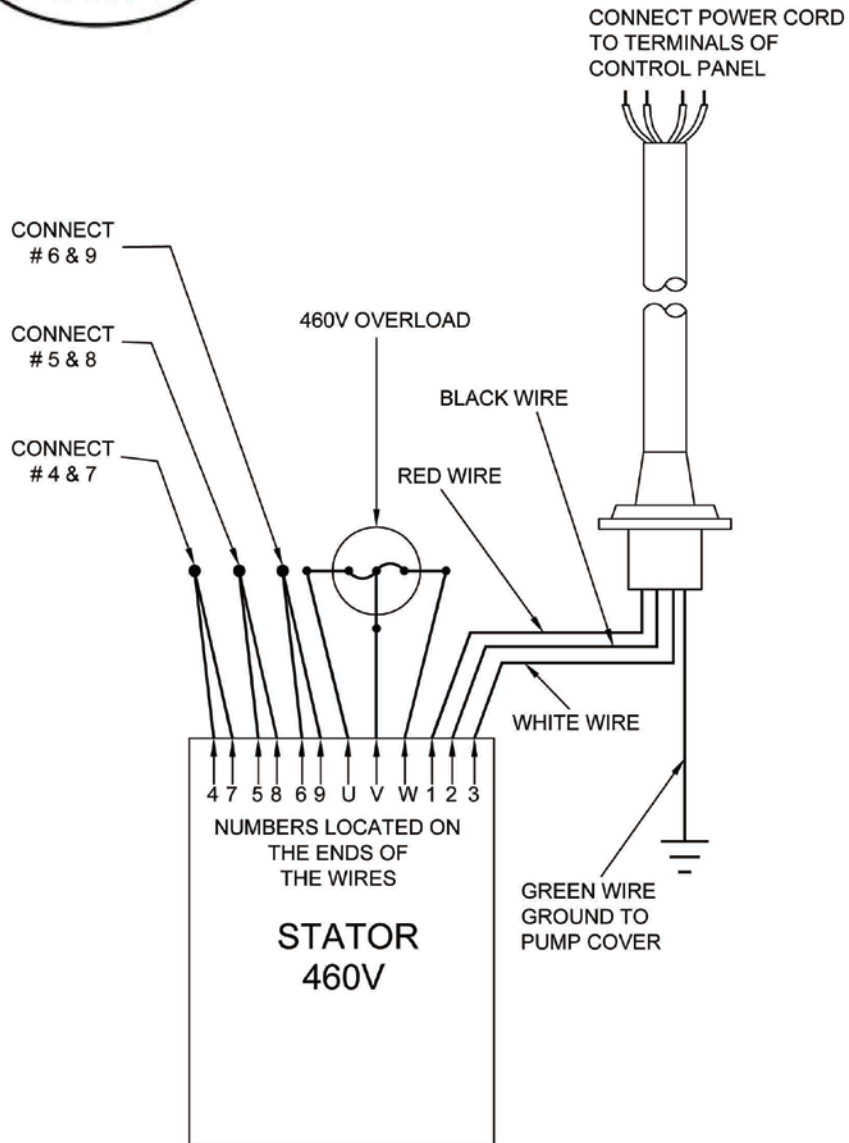

BJM Pumps, LLC - 123 Spencer Plain Road, Old Saybrook, CT 06475 - Phone:860-399-5937 - Fax:860-399-7784

REVISION 6/11/2004

Page 1 of 1

SPECIFICATIONS SUBJECT TO CHANGE WITHOUT NOTICE

MODELS SK08C, SKX08CSS, SK15C, SKX15CSS, SK22C, SKX22CSS, SK37C, SKX37CSS, SK55C, SKX55CSS, SKX75C, SKX75CSS, SK110C, SKX110CSS, SK150C, SKX150CSS

575V



WIRING DIAGRAM
THREE PHASE 575V

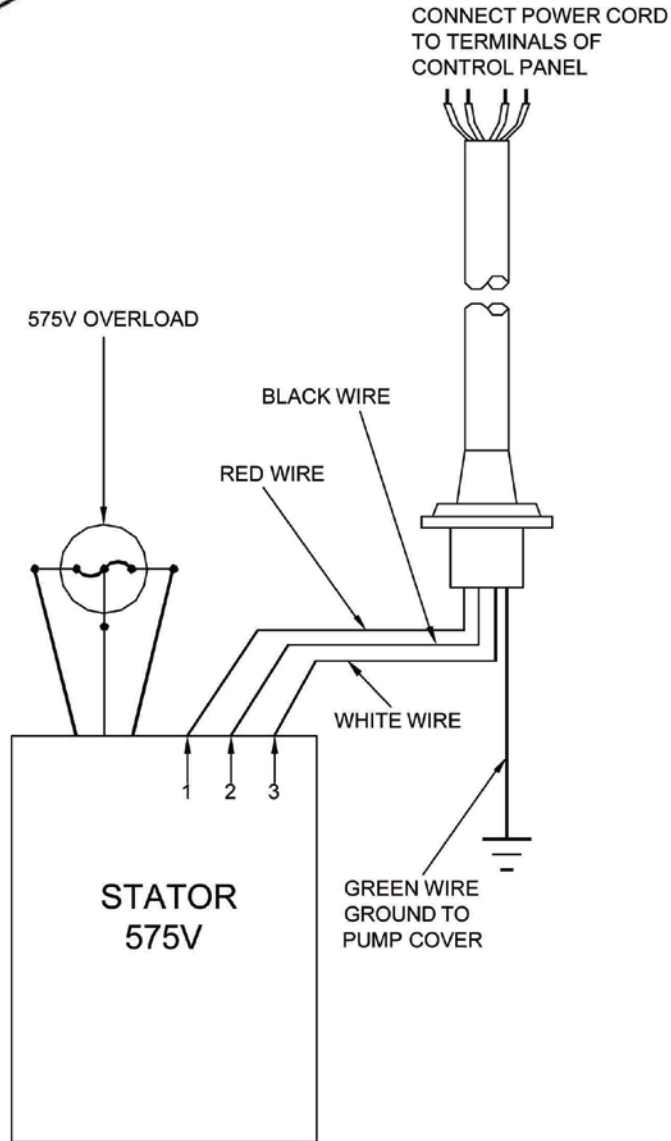

NOTE: 575V STATORS ARE SINGLE VOLTAGE STATORS AND HAVE 6 WIRE LEADS.

BJM Pumps, LLC - 123 Spencer Plain Road, Old Saybrook, CT 06475 - Phone:860-399-5937 - Fax:860-399-7784

REVISION 4/28/2006

Page 1 of 1

SPECIFICATIONS SUBJECT TO CHANGE WITHOUT NOTICE

MODELS SK08C, SKX08CSS, SK15C, SKX15CSS, SK22C, SKX22CSS, SK37C,
SKX37CSS, SK55C, SKX55CSS, SKX75C, SKX75CSS, SK110C, SKX110CSS, SK150C,
SKX150CSS

SEAL MINDER®



Seal Minder® INFORMATION

Seal Minder:

Also known as a seal failure circuit (or moisture detection circuit) is designed to inform the pump operator that there is moisture within the oil chamber. This early warning can allow the operator to schedule repair & inspection on the pump. The **Seal Minder** is a sensor probe inside the oil chamber. (The oil chamber houses the mechanical seals that are cooled & lubricated by oil). The **Seal Minder**, when properly connected to a control panel, can help indicate seal failure. The **Seal Minder** cord requires a seal fail circuit in control panel for warning signal.

The open end of the **Seal Minder** circuit cord should be connected to a control panel with an optional seal failure alarm relay circuit or a standalone **Seal Minder** Panel manufacturers can incorporate the **Seal Minder** cord option. BJM Pumps, LLC has a stand alone, **Seal Minder** panel for both simplex (P/N MSP8350A) and duplex (P/N MSP8350B) systems. For more information contact BJM Pumps, LLC or visit us online at www.bjmpumps.com

The **Seal Minder** cord has two leads, black and white. Note that the power cable is much larger and has 3 to five leads, depending on the model. Inside the pump, the black lead is connected to the casing ground, and the white lead is connected to the seal probe that is suspended into the oil chamber fluid. These leads need to be properly connected to the seal failure alarm relay circuit. Most controls that have provided for this option have a connection terminal point that is clearly marked for these connections. Consult the control panel manual for proper connection instructions.

Although highly recommended, the pump does not need a control box with seal fail relay or stand alone seal panel to operate.

If the operator does not use the Seal Minder:

1. The recommended procedure is to take the **Seal Minder** cord off the pump and seal with a **Seal Minder** cap (P/N M02738) and gasket (P/N M05121 for Buna, P/N M05121V for FKM). This should be done by an authorized BJM Pumps service center or distributor as not to void warranty Detailed instruction sheet available for this procedure.
2. Alternate method of securing **Seal Minder** cable if not being used: Tape the **Seal Minder** cord to the power cord. Make sure that the cords are taped together in an even run, at about 2' to 3' apart. Use electrical tape to tape off the end of the **Seal Minder** cable (Do not connect to power source). The taped leads should be kept dry and out of the liquid. (See next page for detailed drawing).

Seal Minder is a registered trademark of BJM Pumps, LLC

Seal Minder CORD DIAGRAM

(Seal Minder CORD REQUIRES A SEAL FAIL CIRCUIT IN CONTROL PANEL FOR WARNING SIGNAL)

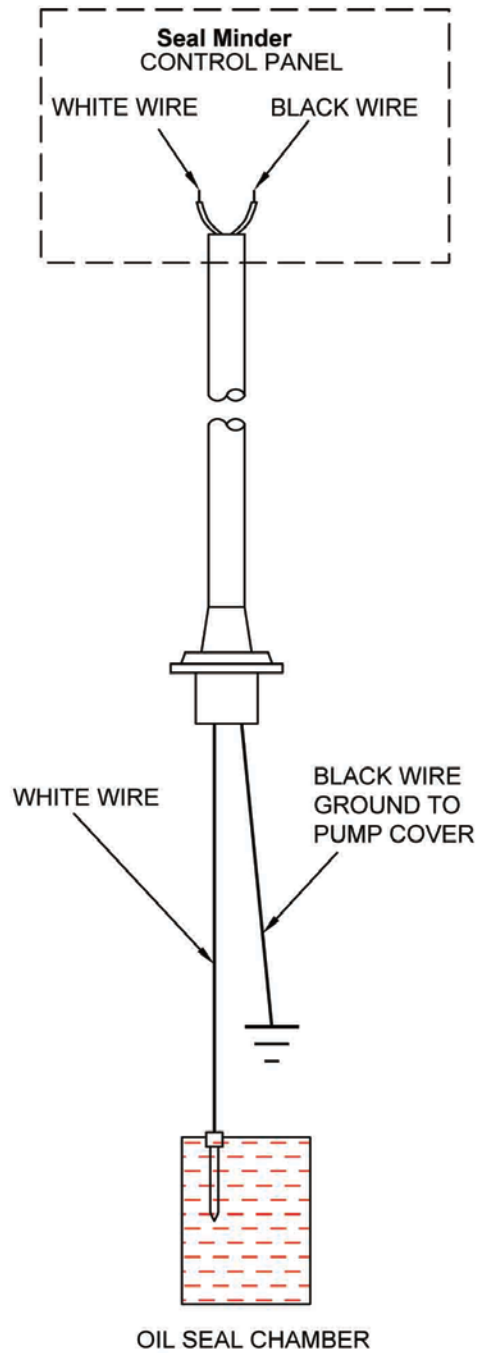

ALTERNATE METHOD OF SECURING Seal Minder CORD IF NOT USED

Seal Minder CORD SHOULD BE SECURED, CAPPED OFF & PROTECTED FROM MOISTURE

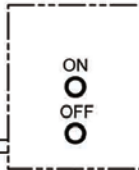

PUMP CONTROL PANEL (OPTIONAL)

TAPE Seal Minder CORD TO POWER CORD IN EVERY 2 TO 3 FEET APART

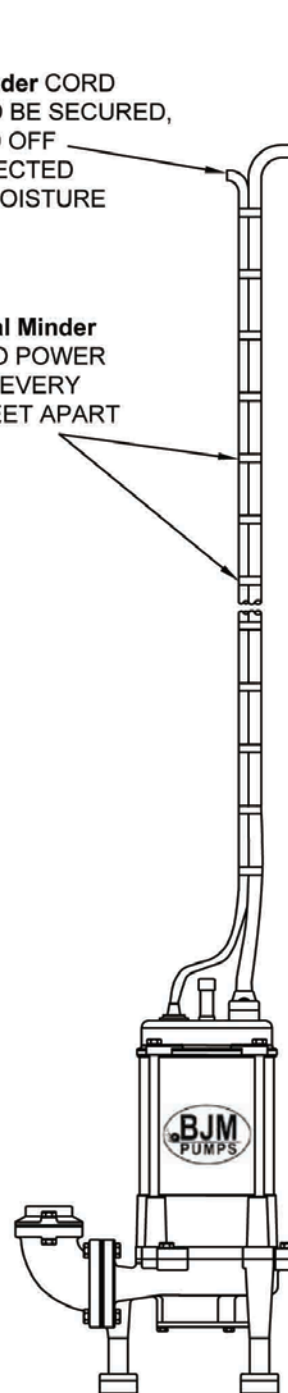

SPECIFICATIONS SUBJECT TO CHANGE WITHOUT NOTICE.

BJM Pumps, LLC - 123 SPENCER PLAIN ROAD, OLD SAYBROOK, CT 06475 - PHONE: 860-399-5937 - FAX: 860-399-7784
BJM Pumps® & Seal Minder® is a registered trademark of BJM Pumps, LLC. Copyright 2006-2009. All rights reserved.

BJM PUMPS, LLC
123 Spencer Plain Road
Old Saybrook, CT 06475, U.S.A.

WARRANTY AND LIMITATION OF LIABILITY

Unless otherwise expressly authorized in writing, specifying a longer or shorter period, BJM Pumps,LLC warrants for a period of eighteen (18) months from the date of shipment from the Point of Shipment, or one (1) year from the date of installation, whichever occurs first, that all products or parts thereof furnished by BJM Pumps,LLC under the brand name **BJM Pumps**, hereinafter referred to as the "Product" are free from defects in materials and workmanship and conform to the applicable specification.

BJM Pumps,LLC's liability for any breach of this warranty shall be limited solely to replacement or repair, at the sole option of BJM Pumps,LLC, of any part or parts of the Product found to be defective during the warranty period, provided the Product is properly installed and is being used as originally intended. Any breach of this warranty must be reported to BJM Pumps,LLC or BJM Pumps,LLC's authorized service representative within the aforementioned warranty period, and defective Product or parts thereof must be shipped to BJM Pumps,LLC or BJM Pumps,LLC's authorized representative, transportation charges prepaid. Any cost associated with removal or installation of a defective Product or part is excluded.

IT IS EXPRESSLY AGREED THAT THIS SHALL BE THE SOLE AND EXCLUSIVE REMEDY OF BJM PUMPS, LLC'S DISTRIBUTORS AND CUSTOMERS. UNDER NO CIRCUMSTANCES SHALL BJM PUMPS, LLC BE LIABLE FOR ANY COSTS, LOSS, EXPENSE, DAMAGES, SPECIAL DAMAGES, INCIDENTAL DAMAGES OR CONSEQUENTIAL DAMAGES ARISING DIRECTLY OR INDIRECTLY FROM THE DESIGN, MANUFACTURE, SALE, USE OR REPAIR OF THE PRODUCT, WHETHER BASED ON WARRANTY, CONTRACT, NEGLIGENCE, OR STRICT LIABILITY. IN NO EVENT WILL LIABILITY EXCEED THE PURCHASE PRICE OF THE PRODUCT.

THE WARRANTY AND LIMITS OF LIABILITY CONTAINED HEREIN ARE IN LIEU OF ALL OTHER WARRANTIES AND LIABILITIES, EXPRESSED OR IMPLIED. ALL IMPLIED WARRANTIES OF MERCHANTABILITY AND FITNESS FOR A PARTICULAR PURPOSE ARE HEREBY DISCLAIMED BY BJM PUMPS, LLC AND EXCLUDED FROM THIS WARRANTY.

BJM Pumps,LLC neither assumes, nor authorizes any person to assume for it, any other warranty obligation in connection with the sale of the Product. This warranty shall not apply to any Product or parts of Product which have (a) been repaired or altered outside of BJM Pumps,LLC's facilities unless such repair was authorized in advance by BJM Pumps,LLC or by its authorized representative; or (b) have been subject to misuse, negligence or accident; or (c) have been used in a manner contrary to BJM Pumps,LLC's instruction.

In any case of products not manufactured and sold under the BJM Pumps,LLC brand name, there is no warranty from BJM Pumps,LLC; however BJM Pumps,LLC will extend any warranty received from BJM Pumps,LLC's supplier of such products.

START-UP REPORT FORM

START-UP REPORT FORM

This form is designed to record the initial installation, and to serve as a guide for troubleshooting at a later date (if needed).

BJM Pumps, LLC
123 Spencer Plain Road
Old Saybrook, CT. 06475

Form with multiple rows for data entry: Pump Owner's Name, Location of Installation, Date of Installation, Dealer, Dealer Phone, Date of Purchase, Model, Serial No, Voltage, Phase, Hertz, HP, Does impeller turn freely by hand?, Condition of Equipment, Condition of Cable Jacket, Rotation: Direction of Impeller Rotation, Resistance of cable and Pump Motor, MEG OHM CHECK OF INSULATION, Condition of location at start-up, Was equipment stored, Liquid being pump, Debris in bottom of station?

START-UP REPORT FORM

Are guide rails vertical?	<input type="checkbox"/> Yes	<input type="checkbox"/> No
Is base elbow installed level?	<input type="checkbox"/> Yes	<input type="checkbox"/> No
Liquid level controls: Model _____		
Is control installed away from turbulence?	<input type="checkbox"/> Yes	<input type="checkbox"/> No
Float Operation Check		
Tip lowest float (stop float), all pumps should remain off. Tip second float (and stop float), one pump comes on. Tip third float (and stop float), both pumps on (alarm on simplex). Tip fourth float (and stop float), high level alarm on (omit on simplex).		
<input type="checkbox"/> Check here if using manual on/off only.		
Does liquid level ever drop below volute top?	<input type="checkbox"/> Yes	<input type="checkbox"/> No
Control Panel MFG & model no.		
Number of pumps operated by control panel		
NOTE: At no time should hole be made in top of control panel, unless proper sealing devices are utilized.		
Short Circuit protection:	Type:	
Number and size of short circuit device(s)	Amp rating:	
Overload type:	Size:	Amp rating:
Do protective devices comply with pump motor amp rating?	<input type="checkbox"/> Yes	<input type="checkbox"/> No
Are all pump connections tight?	<input type="checkbox"/> Yes	<input type="checkbox"/> No
Is the interior of the panel dry?	<input type="checkbox"/> Yes	<input type="checkbox"/> No If No, correct moisture problem.
Electrical readings		
SINGLE PHASE		
Voltage supply at panel line connection, pump off	L1	L2
Voltage supply at panel line connection, pump on	L1	L2
Amperage load connection, pump on	L1	L2
THREE PHASE		
Voltage supply at panel line connection, pump off		
L1-L2	L2-L3	L3-L1
Voltage supply at panel line connection, pump on		

START-UP REPORT FORM

L1-L2	L2-L3	L3-L1
Amperage load connection, pump on		
L1	L2	L3
FINAL CHECK		
Is pump secured properly?	<input type="checkbox"/> Yes	<input type="checkbox"/> No
Was pump checked for leaks?	<input type="checkbox"/> Yes	<input type="checkbox"/> No
Do check valves operate properly?	<input type="checkbox"/> Yes	<input type="checkbox"/> No
Flow: Do pumps appear to operate at proper rate?	<input type="checkbox"/> Yes	<input type="checkbox"/> No
Noise level:	Acceptable <input type="checkbox"/>	Unacceptable <input type="checkbox"/>
Comments:		
Installed by:		
Company:		
Person:		
Date:		

123 Spencer Plain Road • PO Box 1138 • Old Saybrook, CT 06475, USA
• Phone: (860) 399-5937 • Fax: (860) 399-7784
Email: sales@bjmcorp.com • Web Site: www.bjmpumps.com

BJM Pumps & Seal Minder is a registered trademark of BJM Pumps, LLC.
Copyright © 2006-2011 BJM Pumps, LLC. All rights reserved.