



INSTALLATION, OPERATION & MAINTENANCE MANUAL

FARHENHEIT™

S-F & SX-F SERIES SIDE DISCHARGE Electric Submersible Pumps

**Three Phase
208V, 230V, 460V & 575V**

CAST IRON THREE PHASE

S08C-F
S15C-F
S22C-F
S37C-F
S55C-F
S75C-F

316 STAINLESS STEEL THREE PHASE

SX08CSS-F
SX15CSS-F
SX22CSS-F
SX37CSS-F
SX55CSS-F
SX75CSS-F

Read this manual carefully before installing, operating or servicing these pump models. Observe all safety information. Failure to comply with instructions may result in personal injury and/or property damage. Please retain these instructions.

TABLE OF CONTENTS

INTRODUCTION.....	4
SAFETY	5
INSPECTION	6
PRE-INSTALLATION INSPECTION	6
OIL FILL QUANTITY/TYPE	6
PUMP INSTALLATION.....	6
POSITIONING THE PUMP.....	7
PUMP ROTATION.....	8
TYPICAL MANUAL WASTEWATER INSTALLATION	9
STOPPING	10
TYPICAL AUTOMATIC WASTEWATER INSTALLATION	10
STOPPING	11
INTENDED METHODS OF CONNECTION	11
THREE PHASE WIRING INSTRUCTIONS.....	11
TROUBLE SHOOTING	13
PUMP WILL NOT RUN.....	13
PUMP RUNS BUT DOES NOT DELIVER RATED CAPACITY	13
SERVICING YOUR SUBMERSIBLE PUMP	13
MAINTAINING YOUR PUMP	14
CHANGING SEAL OIL	14
EXPLODED VIEW OF S08C-F, SX08CSS-F, S15C-F, SX15CSS-F	15
EXPLODED VIEW OF S22C-F, SX22CSS-F, S37C-F, SX37CSS-F	16
EXPLODED VIEW OF S55C-F, SX55CSS-F, S75C-F, SX75CSS-F	17
S-F SERIES PARTS LIST.....	18
SX-F SERIES PARTS LIST	20
THREE PHASE WIRING DIAGRAMS	22
208V.....	22
MODELS S08C-F, SX08CSS-F, S15C-F, SX15CSS-F, S22C-F, SX22CSS-F, S37C-F, SX37CSS-F, S55C-F, SX55CSS-F, S75C-F, SX75CSS-F	22
230V.....	23
MODELS S08C-F, SX08CSS-F, S15C-F, SX15CSS-F, S22C-F, SX22CSS-F, S37C-F, SX37CSS-F, S55C-F, SX55CSS-F, S75C-F, SX75CSS-F	23
460V.....	24
MODELS S08CF, SX08CSS-F, S15C-F, SX15CSS-F, S22C-F, SX22CSS-F, S37C-F, SX37CSS-F, S55C-F, SX55CSS-F, S75C-F, SX75CSS-F	24
575V.....	25
MODELS S08C-F, SX08CSS-F, S15C-F, SX15CSS-F, S22C-F, SX22CSS-F, S37C-F, SX37CSS-F, S55C-F, SX55CSS-F, S75C-F, SX75CSS-F	25
SEAL MINDER®- THERMAL MOTOR SENSOR SWITCH.....	26
WARRANTY AND LIMITATION OF LIABILITY	28
START-UP REPORT FORM.....	29
NOTES:.....	32



INTRODUCTION

This Installation, Operation and Maintenance manual provides important information on safety and the proper inspection, disassembly, assembly and testing of the BJM Pumps® S-F & SX-F Series submersible pump. This manual also contains information to optimize performance and longevity of your **BJM Pumps** submersible pump. The F Series **Fahrenheit**™ pumps are engineered to pump water based liquids up to 200° Fahrenheit (93°C).

The submersible S-F Series pumps are designed to pump water and wastewater. The SX-F Series pumps are designed to pump corrosive liquids in concentrations chemically compatible with 316SS and FKM. The S-F & SX-F Series pumps are not explosion-proof. They are not designed to pump volatile or flammable liquids.

Note: Consult chemical resistance chart for compatibility between pump materials and liquid before operating pump. Consult BJM engineering if there is a question on chemical compatibility.

If you have any questions regarding the inspection, disassembly, assembly or testing please contact your **BJM Pumps** distributor, or BJM Pumps, LLC.

BJM Pumps, LLC
123 Spencer Plain Rd
Old Saybrook, CT 06475, USA

Phone: 877-256-7867
Phone: 860-399-5937
Fax: 860-399-7784

Information, including pump data sheets and performance curves, is also available on our web site: www.bjmpumps.com

For assistance with your electric power source, please contact a certified electrician.

Please pay attention to the following alert notifications. They are used to notify operators and maintenance personnel to pay special attention to procedures, to avoid causing damage to the equipment, and to avoid situations that could be dangerous to personnel.

NOTE: Instructions to aid in installation, operation, and maintenance or which clarify a procedure.

⚠ DANGER

Immediate hazards that WILL result in severe personal injury or death. These instructions describe the procedure required and the injury which will result from failure to follow the procedure.

⚠ WARNING

Hazards or unsafe practices that COULD result in severe personal injury or death. These instructions describe the procedure required, and the injury which could result from failure to follow the procedure.



⚠ CAUTION

Hazards or unsafe practices which COULD result in personal injury or product or property damage. These instructions describe the procedure required and the possible damage which could result from failure to follow the procedure.

SAFETY

Pump installations are seldom identical. Each installation and application can vary due to many different factors. It is the owner/service mechanics responsibility to repair, service, and test to ensure that the pump integrity is not compromised according to this manual.

⚠ WARNING

Risk of electric shock – this pump has not been investigated for use in swimming pool areas.

⚠ DANGER

Do not pump flammable or volatile liquids. Death or serious injury will result.

⚠ WARNING

Before attempting to open or service the pump:

- 1) Familiarize yourself with this manual.
- 2) Unplug or disconnect the pump power cable to ensure that the pump will remain inoperative.
- 3) Allow the pump to cool if overheated.

⚠ WARNING

Do not operate the pump with a worn or damaged electric power cable. Death or serious injury could occur.

⚠ WARNING

Never attempt to alter the length or repair any power cable with a splice. The pump motor and pump motor and cable must be completely waterproof. Damage to the pump or personal injury may result from alterations.

⚠ WARNING

After the pump has been installed, make sure that the pump and all piping are secure before operation.

⚠ WARNING

Do not lift the pump by the power cable piping or discharge hose. Attach proper lifting equipment to the lifting handle (or lifting rings) fitted to the pump. Do not suspend the pump by the power cable.

⚠ WARNING

Obtain the services of a qualified electrician to troubleshoot, test and/or service the electrical components of this pump.

⚠ CAUTION

Pumps and related equipment must be installed and operated according to all national, local and industry standards.



INSPECTION

Review all safety information before servicing pump.

The following are recommended installation practices/procedures for the pump. If there are questions in regards to your specific application, contact your local **BJM Pumps** distributor or BJM Pumps, LLC.

PRE-INSTALLATION INSPECTION

- 1) Check the pump for damage that may have occurred during shipment.
- 2) Inspect the pump for any cracks, dents, damaged threads, etc.
- 3) Check power cord and sensor cable for any cuts or damage.
- 4) Check for, and tighten any hardware that appears loose.
- 5) Carefully read all tags, decals and markings on the pump.
- 6) **Important:** Always verify that the pump nameplate, amps, voltage, phase, and HP ratings match your control panel and power supply.

Warranty does not cover damage caused by connecting pumps and controls to an incorrect power source (voltage/phase supply). Record the model numbers and serial numbers from the pumps and control panel on the front of this instruction manual for future reference. Give it to the owner or affix it to the control panel when finished with the installation.

If anything appears to be abnormal, contact your **BJM Pumps** distributor or BJM Pumps, LLC. If damaged, the pump may need to be repaired before use. Do not install or use the pump until appropriate action has been taken.

Lubrication:

No additional lubrication is necessary. The shaft seal and bearings are fully lubricated from the factory. Seal oil should be checked once per year. See table below.

OIL FILL QUANTITY/TYPE

OIL IN SEAL CHAMBER			
MODEL	U.S. FL. OZ.	CC.	TYPE OF OIL
S08C-F	6.8	201	ISO 32 NSF Food Grade Mineral Oil
S15C-F	7.8	230	ISO 32 NSF Food Grade Mineral Oil
S22C-F	10	296	ISO 32 NSF Food Grade Mineral Oil
S37C-F	10	296	ISO 32 NSF Food Grade Mineral Oil
S55C-F	35.5	1050	ISO 32 NSF Food Grade Mineral Oil
S75C-F	35.5	1050	ISO 32 NSF Food Grade Mineral Oil
OIL IN SEAL CHAMBER			
MODEL	U.S. FL. OZ.	CC.	TYPE OF OIL
SX08CSS-F	6.75	200	ISO 32 NSF Food Grade Mineral Oil
SX15CSS-F	6.75	200	ISO 32 NSF Food Grade Mineral Oil
SX22CSS-F	12	355	ISO 32 NSF Food Grade Mineral Oil
SX37CSS-F	12	355	ISO 32 NSF Food Grade Mineral Oil
SX55CSS-F	35.5	1050	ISO 32 NSF Food Grade Mineral Oil
SX75CSS-F	35.5	1050	ISO 32 NSF Food Grade Mineral Oil

NOTE: The stator on this model is oil filled. This needs to be changed annually when the seal oil is



changed. With the power cable entry removed, fill the motor chamber with oil to a level that insures the oil is covering the motor windings by $\frac{1}{2}$ ", and that will be above the upper bearing. Do not overfill, an air gap of 10-15% must be maintained for heat expansion.

PUMP INSTALLATION

S-F & SX-F Series pumps have been evaluated for use with water or water based solutions. Please contact the manufacturer for additional information.

⚠ WARNING

Risk of electric shock. Three phase pumps do not come with electric plug connectors. To reduce the risk of electric shock, be certain that it is connected only to a properly grounded, grounding-type receptacle.

Lifting:

Attach a rope or lifting chain (not included) to the handle (or lifting rings) on the top of the pump.

⚠ CAUTION

Do not lift the pump by the power cable or discharge hose/piping. Proper lifting equipment (rope/chain) must be used.

POSITIONING THE PUMP

BJM Pumps, S-F & SX-F Series pumps are designed to operate fully submerged. Data sheets can be obtained online at www.bjmpumps.com or by calling BJM Pumps, LLC at 860-399-5937.

⚠ CAUTION

- Do not run the pump dry.
- Pump liquid should not exceed a maximum temperature of 200°F (93°C).
- Never place the pump on loose or soft ground. The pump may sink, preventing water from reaching the impeller. Place on a solid surface or suspend the pump with a lifting rope/chain. The S-F & SX-F Series pumps are provided with a suction strainer to prevent large solids from clogging the impeller. Any spherical solids which pass through the strainer should pass through the pump.
- For maximum pumping capacity, use the proper size non-collapsible hose or rigid piping. A check valve may be installed after the discharge to prevent back flow when the pump is shut off.



PUMP ROTATION

Two ways to check the correct pump rotation:

1. By looking at the impeller; the rotation of the impeller should be counter clockwise as shown in the picture below.

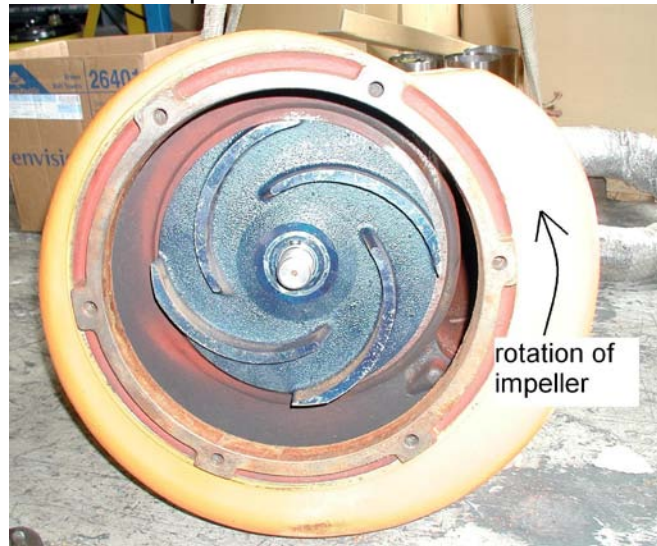

2. By looking from the top of the pump. Since the impeller cannot be seen, the best way to check the rotation is to check the kick back motion of the pump when the pump just starts. The kick back motion of the pump should be counter clockwise as shown in the picture below.





PUMP OPERATION

⚠ WARNING

This pump is designed to handle dirty water that contains some solids. It is not designed to pump volatile or flammable liquids. Do not attempt to pump any liquids which may damage the pump or endanger personnel as a result of pump failure.

⚠ DANGER

Do not operate this pump where explosive vapors or flammable material exist. Death or Serious injury will result.

TYPICAL MANUAL WASTEWATER INSTALLATION

NOTE: Maximum recommended starts should not exceed 10 times per hour.

All S-F & SX-F models are provided with a 33' (10 m) power cord. NEVER splice the power cable due to safety and warranty considerations. Always keep the lead end dry. Note: 208V, 230V, 460V & 575V three phase units do not have a plug and have to be provided separately.

⚠ WARNING

Do not alter the length or repair any power cable with a splice. The pump motor and cable must be completely waterproof. Damage to the pump or personal injury may result from alterations.

For manual operation: 208, 230, 460 & 575 volt: Connect directly to the power source or control box. Check the direction of the rotation. Tilt the pump and start it. It should twist in the opposite direction of the arrow (on pump).

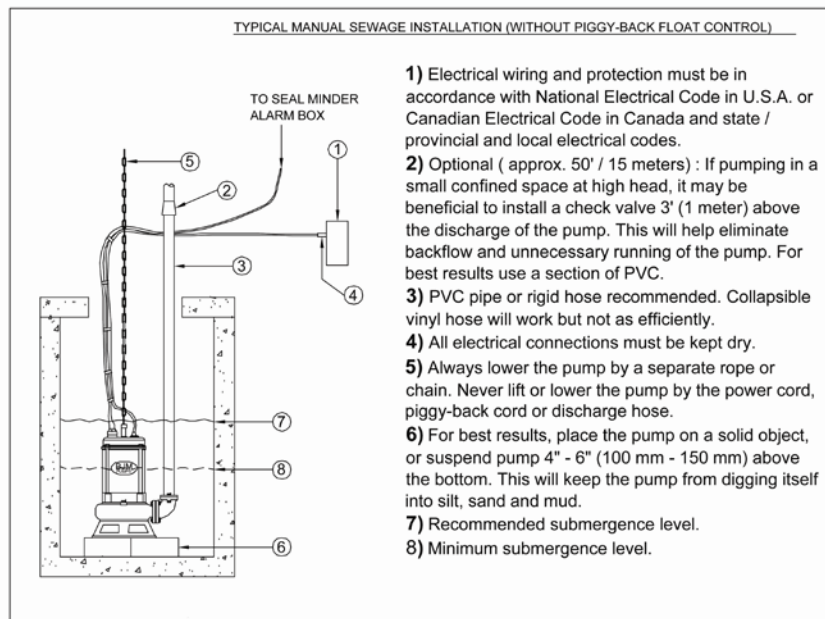



STOPPING

To stop the pump (manual and automatic mode), turn off the breaker, or turn the power source off (generator).

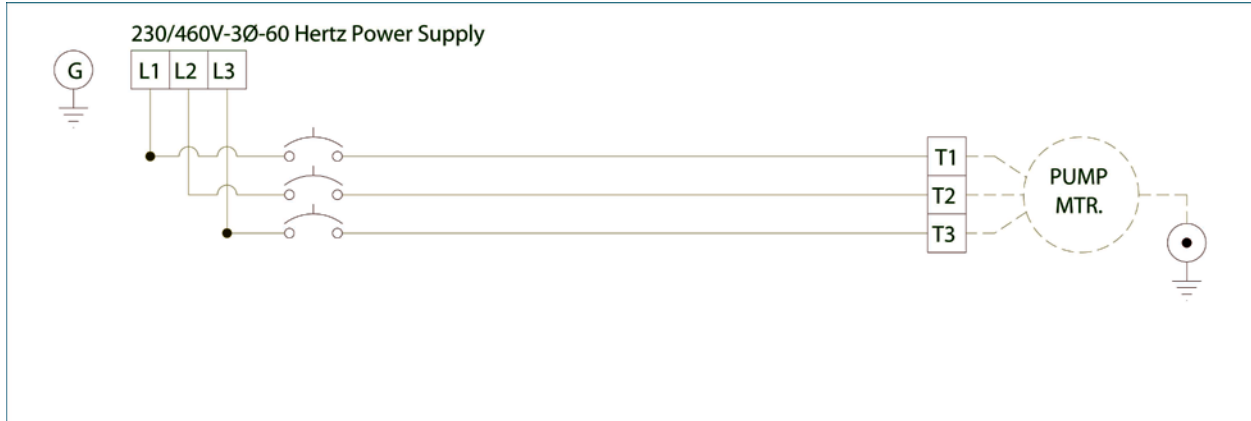

Typical 3 Phase Manual Control 1

TYPICAL AUTOMATIC WASTEWATER INSTALLATION

NOTE: Maximum recommended starts should not exceed 10 times per hour.

Three phase pumps need a separate control box with float(s) for automatic operation.

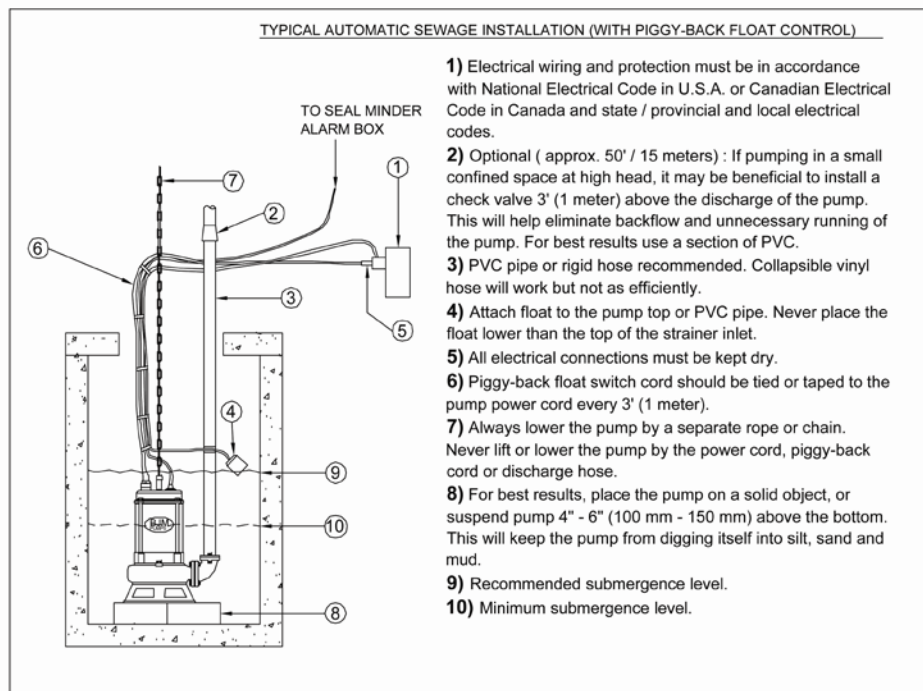

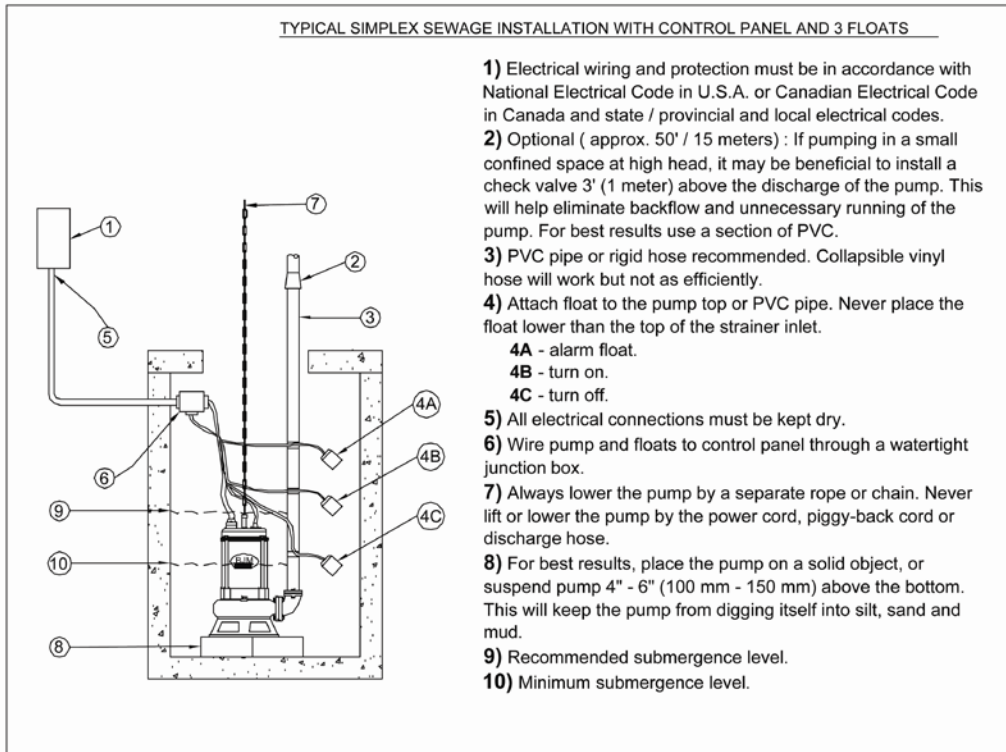

STOPPING

To stop the pump (manual and automatic mode), unplug it from the power source, turn off the breaker, or turn the power source off (generator).

INTENDED METHODS OF CONNECTION

⚠ CAUTION Use with approved motor control that matches motor input in full load amperes. "UTILISER UN DÉMARREUR APPROUVÉ CONVARIANT AU COURANT À PLEINE CHARGE DU MOTEUR."

BJM Pumps has been evaluated for use with water or water based solutions. Please contact the manufacturer for additional information.

THREE PHASE WIRING INSTRUCTIONS

⚠ WARNING FOR YOUR PROTECTION, ALWAYS DISCONNECT PUMP FROM ITS POWER SOURCE BEFORE HANDLING.

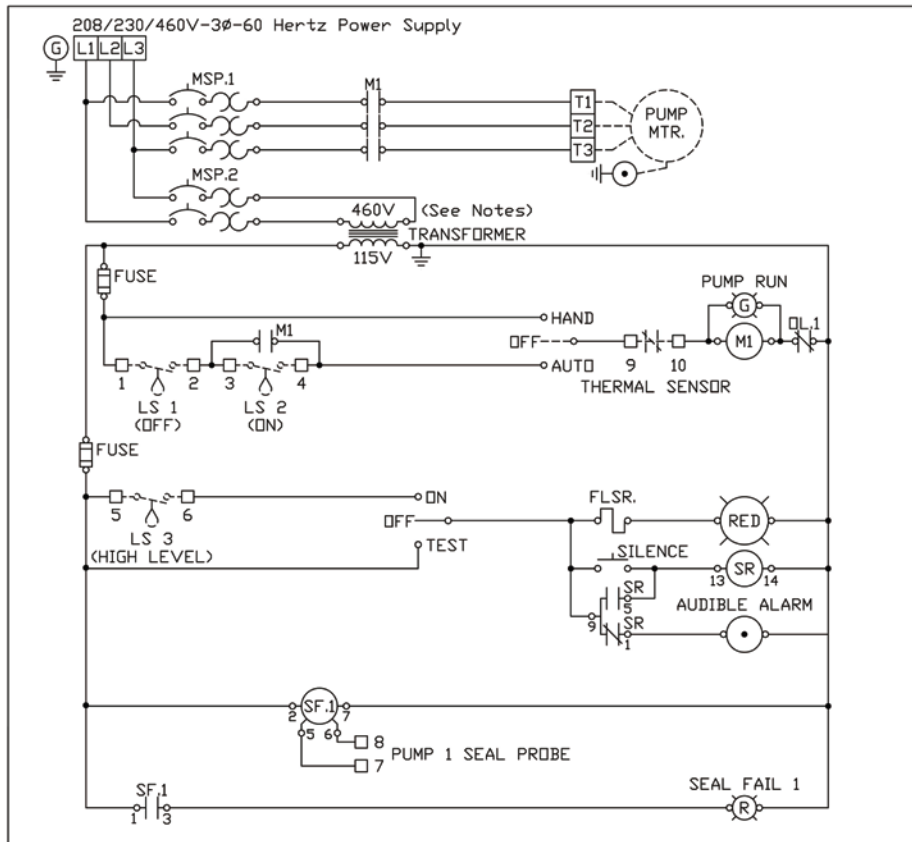

Typical 3 Phase Auto Control 1

⚠ CAUTION

“Risk of electrical shock” Do not remove power supply cord and strain relief.

⚠ WARNING

Installation and checking of electrical circuits and hardware should be performed by a qualified licensed electrician.

To automatically operate a non-automatic three phase pump, a control panel is required. Follow the instructions provided with the panel to wire the system. For automatic three phase pumps see automatic three phase wiring diagram.

Before installing a pump, make sure both of the ground leads and the power leads have been connected properly. Once the power connections have been confirmed, then check the pump rotation. Momentarily energize the pump, observing the directions of kick back due to starting torque. Rotation is correct if kick back is in the opposite direction of rotation arrow on the pump casing. If rotation is not correct, switching of any two power leads other than ground will provide the proper rotation.

⚠ DANGER

DO NOT PLACE HANDS IN PUMP SUCTION WHILE CHECKING MOTOR ROTATION. TO DO SO WILL CAUSE SEVERE PERSONAL INJURY.



Three phase pumps DO NOT have integral motor overload protection. Pumps **must** be installed in accordance with the National Electrical Code and all applicable local codes and ordinances. Pumps are not to be installed in locations classified as hazardous in accordance with National Electrical Code, ANSI/NFPA 70.

Connect pump to a junction box, outlet box, control box, enclosure with a wiring compartment that meets NEC and local codes. The provision for supply connection shall reduce the risk of water entry during temporary, limited submersion and shall comply with the applicable requirements of the Standard for Enclosures for Electrical Equipment, UL 50, or the standard for Metallic Outlet Boxes, UL 514A, and the standard for Motor-Operated Water Pumps. UL 778.

TROUBLE SHOOTING



Disconnect the power source to the pump BEFORE attempting any type of trouble shooting, service or repair.

PUMP WILL NOT RUN

1. Check power supply (fuses, breaker). Reset power.
2. Blocked impeller. Remove strainer, check and clean.
3. Defective cable or incorrect wiring.
4. Strainer clogged. Check and clean as necessary.
5. Float switch tangled/obstructed. Clean and free float switch from obstruction.
6. Float switch defective. Replace float switch.

PUMP RUNS BUT DOES NOT DELIVER RATED CAPACITY

1. Discharge line clogged, restricted or hose kinked. Check discharge hose/pipe.
2. Worn impeller and/or suction cover. Inspect and replace as necessary.
3. Pump overloaded due to liquid pumped being too thick.
4. Pumping air. Check liquid level and position of pump.
5. Excessive voltage drops due to long cables.
6. Three phase only; pump running backwards, check rotation.

SERVICING YOUR SUBMERSIBLE PUMP

Pump should be disconnected from the electric power supply before proceeding to do any service or maintenance.

To service or repair your pump, please contact your local **BJM Pumps** distributor. Service should only be performed by a qualified electrician. The design of the "F" series high temperature pump models is unique and requires specific knowledge to perform the proper assembly. BJM Pumps recommends that all electrical service work be performed at the factory to insure that the materials and assembly methods meet BJM standards.



MAINTAINING YOUR PUMP

- Pump should be disconnected from the electric power supply before proceeding to do any service or maintenance.
- Pump should be inspected at regular intervals.
- More frequent inspections are required if the pump is used in a harsh environment.
- Preventative maintenance should be performed to reduce the chance of premature failure.
- Worn impellers and lip seals should be replaced.
- Cut or cracked power cords must be replaced. **(Never operate a pump with a cut, cracked or damaged power cord.)**
- Seal oil should be checked once per year.
- Maintenance should always be done when taking a pump out of service before storage.
 - 1) Clean pump of dirt and other build up.
 - 2) Check condition of oil around the shaft seals.
 - 3) Check hydraulic parts: check for wear.
 - 4) Inspect power cable. Make sure that it is free of nicks or cuts.

CHANGING SEAL OIL

Changing the seal oil in the S-F & SX-F Series pumps is very easy.

- 1) Make sure that the pump is de-energized and locked out for service.
- 2) Lay the pump down on its side.
- 3) Remove the screws that hold the bottom plate in place.
- 4) Remove bottom plate.
- 5) Remove screws holding the suction cover.
- 6) Remove the suction cover.
- 7) Remove the impeller.
- 8) Remove the inspection screw for the oil chamber (pos#50-08). Pour out a small sample of the oil. If it is milky white, or contains water, then the oil and possible, the mechanical seal, should be changed. If an oil change is needed:
- 9) Remove the screws that hold the oil chamber cover in place & remove the oil.
- 10) Replace the mechanical seal if necessary.
- 11) Replace the oil.
- 12) Assemble the pump.



EXPLODED VIEW OF S08C-F, SX08CSS-F, S15C-F, SX15CSS-F

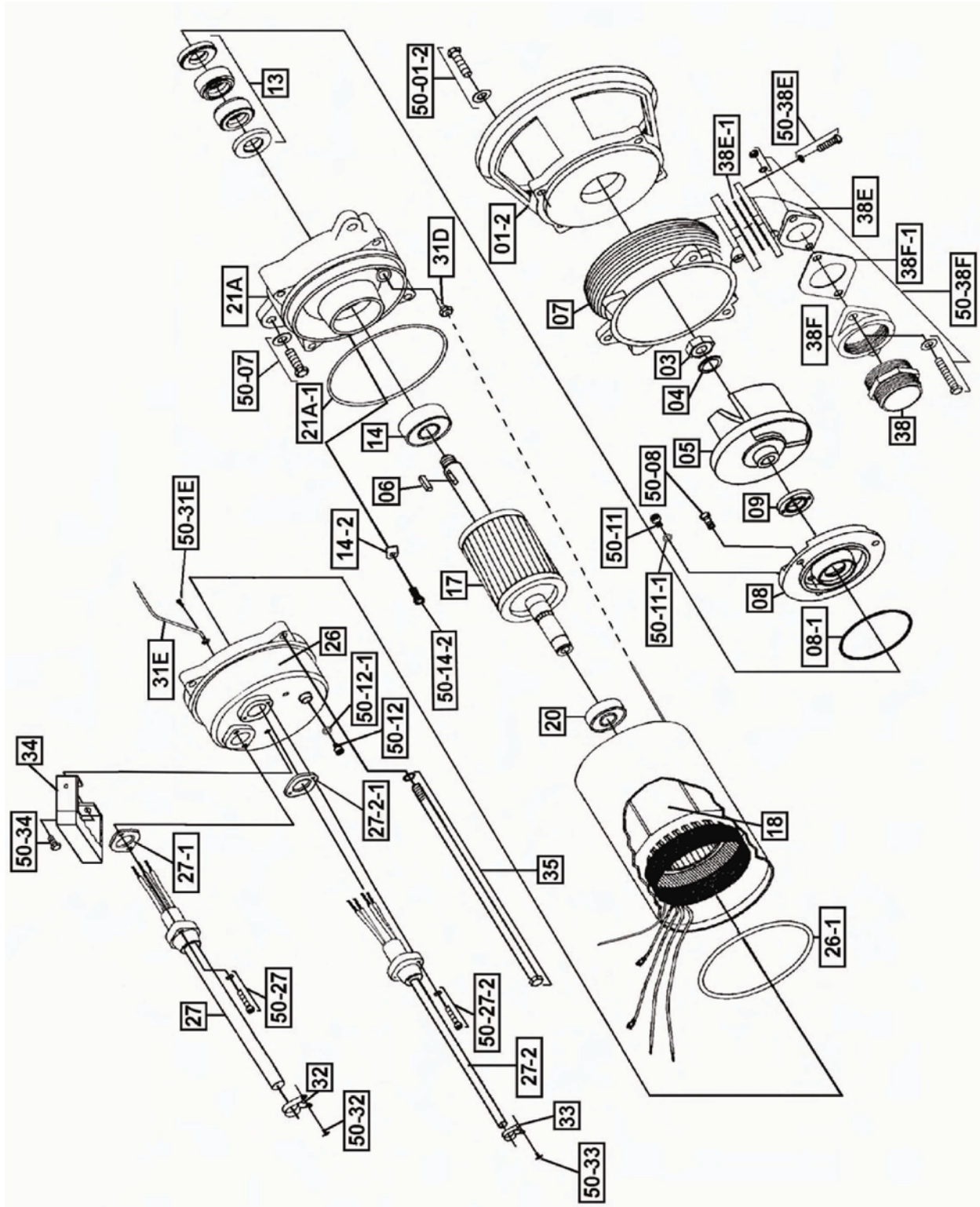



EXPLODED VIEW OF S22C-F, SX22CSS-F, S37C-F, SX37CSS-F

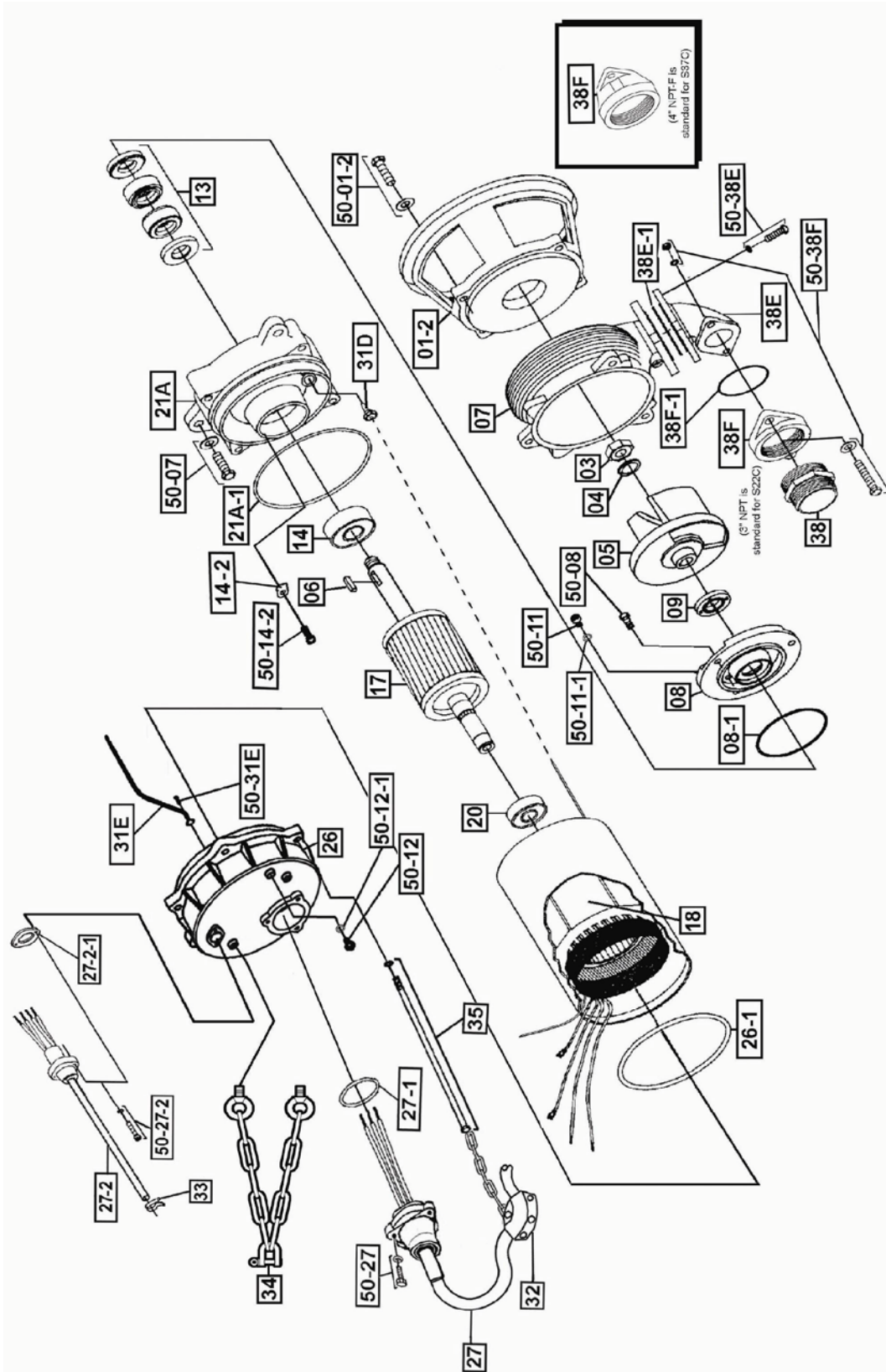



EXPLODED VIEW OF S55C-F, SX55CSS-F, S75C-F, SX75CSS-F

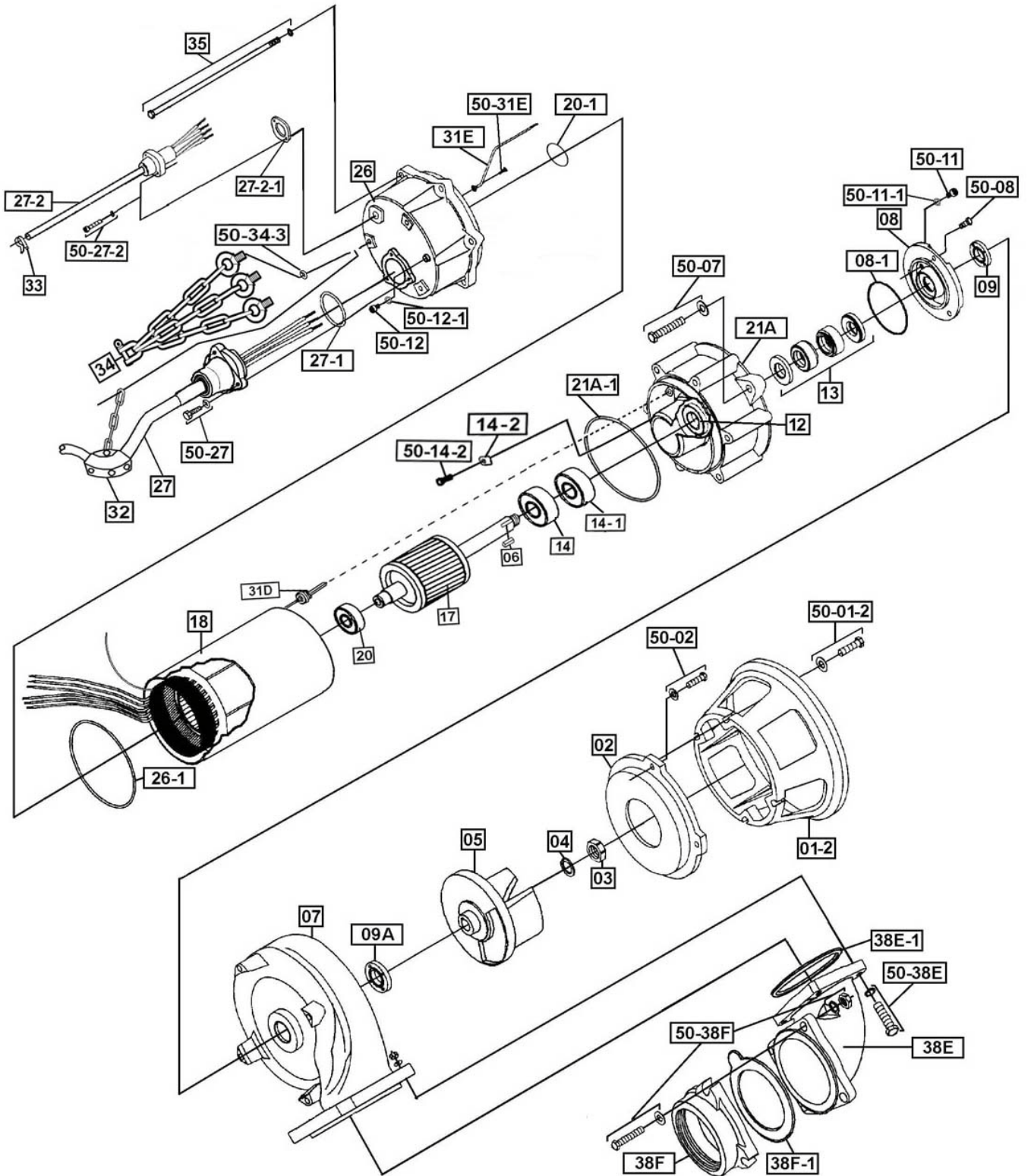

S-F SERIES PARTS LIST

	Pump Model	S08CF	S15CF	S22CF	S37CF	S55CF	S75CF
Pos. No.	Part Description	Part #	Part #	Part #	Part #	Part #	Part #
01-2	Stand	113C	114C	117C	118C	122C	122C
02	Bottom Plate	-	-	-	-	137C	137C
03	Impeller Nut	305	305	305	305	308C	308C
04	Impeller Washer	405C	405C	405C	405C	420	420
05	Impeller	553C	554C	555C	556C	560C	561C
06	Impeller Key	602	602	602	602	603C	603C
07	Pump Housing	719C	718C	721C	723C	743C	743C
08	Oil Chamber Cover	810C	810C	822C	822C	812C	812C
08-1	O-Ring (Kit Only)	Kit	Kit	Kit	Kit	Kit	Kit
09	Lip Seal FKM	903CV	903CV	905CV	905CV	912CV	912CV
09A	Lower Lip Seal FKM	-	-	-	-	912CV	912CV
12	Lip Seal for Lower Bearing	-	-	-	-	907CV	907CV
13	Mechanical Seal FKM	200214	200214	200301	200301	200304	200304
14	Lower Ball Bearing	1401	1401	1402	1402	1404	1405C
14-1	Lower Ball Bearing	-	-	-	-	1404	1405C
14-2	Lower Bearing Retainer Clip	1453	1453	1453	1453	1453	1453
17	Rotor w/ Shaft, 3PH	1708C	1709C	1710C	1711C	1715C	1716C
18	Stator w/ Casing 208V, 3 PH	200525	200529	200533	200537	200666	-
18	Stator w/ Casing 230/460V, 3PH	200547	200551	200555	200559	200563	200567
18	Stator w/ Casing 575V, 3PH	200589	200593	200597	200601	200606	200610
20	Upper Ball Bearing	2002	2002	2004	2004	2005	2005
20-1	O-Ring (Kit Only)	-	-	-	-	Kit	Kit
21A	Oil Chamber/Motor Housing	752C	752C	753C	753C	722C	714C
21A-1	O-Ring (Kit Only)	Kit	Kit	Kit	Kit	Kit	Kit
26	Pump Top Cover (W/ Sensor opening)	2670B	2670B	2671B	2671B	2672B	2672B
26-1	O-Ring (Kit Only)	Kit	Kit	Kit	Kit	Kit	Kit
27	Power Cable w/ Gland-3PH(high temp)	2722F	2722F	2731F	2731F	2731F	2731F
27-1	O-Ring (Kit Only)	Kit	Kit	Kit	Kit	Kit	Kit
27-2	Seal Minder/Temp. Sensor Cord (High Temp)	2736BF	2736BF	2736BF	2736BF	2736BF	2736BF
27-2-1	O-Ring Kit Only	Kit	Kit	Kit	Kit	Kit	Kit
31D	Seal Minder Sensor w/ wire	2330	2330	2330	2330	2330	2330
31E	Ground Wire w/Ring Term.	2776	2776	2776	2776	2776	2776

32	Power Cord Line Clip / Strain Relief	3200	3200	3208	3208	3208	3208
33	Seal Minder Sensor Cord Line Clip	3203	3203	3203	3203	3203	3203
34	Handle / Chain Handle	3420	3420	3413	3413	3418	3418
35	Rod Bolts	4105	4106	4107	4108	4109	4110
38	Discharge Nipple 2"	3802	-	-	-	-	-
38	Discharge Nipple 3"	3804	3804	3804	3804	-	-
38E	Discharge Elbow	3831	3820C	3820C	3820C	3821C	3821C
38E-1	Gasket, Discharge Elbow Viton	4075V	4072V	4072V	4072V	4073V	4073V
38F	Discharge Flange 2"	3822	-	-	-	-	-
38F	Discharge Flange 3"	-	3810	3810	3810	-	-
38F	Discharge Flange 4"	-	-	3816C	3816C	3806C	3806C
38F-1	Gasket, Discharge Flange FKM	4070V	4071V	4071V	4071V	4073V	4073V
50-01-2	Bolt for Strainer/Stand	5013	5013	5013	5013	5014	5014
50-02	Bolt for Suction Cover	-	-	-	-	5014	5014
50-07	Screw for Oil Chamber/Motor Housing	5013	5013	5013	5013	5014	5014
50-08	Screw for Oil Chamber Cover	5009	5009	5009	5009	5034	5034
50-11	Screw for Oil Fill	5008	5008	5008	5008	5008	5008
50-11-1	O-Ring (Kit Only)	Kit	Kit	Kit	Kit	Kit	Kit
50-12	Screw for Pressure Check	5008	5008	5008	5008	5008	5008
50-12-1	O-Ring (Kit Only)	Kit	Kit	Kit	Kit	Kit	Kit
50-14-2	Screw	5009	5009	5009	5009	5009	5009
50-27	Screw for Power Cord	5004	5004	5034	5034	5034	5034
50-27-2	Screw for Oil Sensor Cord	5004	5004	5004	5004	5004	5004
50-31E	Screw for Ground Wire	5000	5000	5000	5000	5000	5000
50-32/50-33	Screw for Line Clip	5001	5001	-	-	-	-
50-34	Screw for Handle	5009	5009	-	-	-	-
50-34-3	Lock Washer	-	-	-	-	402	402
50-38E	Bolt for Discharge Elbow	5041	5043	5043	5043	5079	5079
50-38F	Bolt for Discharge Flange	5083	5083	5083	5041	5081	5081
O-Ring Kit - FKM		4046CV	4046CV	4044CV	4044CV	4045CV	4045CV

SX-F SERIES PARTS LIST

	Pump Model	SX08CSSF	SX15CSSF	SX22CSSF	SX37CSSF	SX55CSSF	SX75CSSF
Pos. No.	Part Description	Part #	Part #	Part #	Part #	Part #	Part #
01-2	Stand	113PX	114PX	117PX	118PX	122CX	122CX
02	Bottom Plate	-	-	-	-	137CX	137CX
03	Impeller Nut	305	305	305	305	308C	308C
04	Impeller Washer	405C	405C	405C	405C	420	420
05	Impeller	553CX	554CX	555CX	556CX	560CX	561CX
06	Impeller Key	602	602	602	602	603C	603C
07	Pump Housing	719PX	718PX	721PX	723PX	743CX	743CX
07-1	O-Ring (Kit Only)	Kit	Kit	Kit	Kit	-	-
08	Oil Chamber Cover	810PX	810PX	822PX	822PX	812CX	812CX
08-1	O-Ring (Kit Only)	Kit	Kit	Kit	Kit	Kit	Kit
09	Lip Seal FKM	903CV	903CV	905CV	905CV	912CV	912CV
09A	Lower Lip Seal FKM	-	-	-	-	912CV	912CV
12	Lip Seal for Lower Bearing	-	-	-	-	907CV	907CV
13	Mechanical Seal FKM	200214	200214	200301	200301	200304	200304
14	Lower Ball Bearing	1401	1401	1402	1402	1404	1405C
14-1	Lower Ball Bearing	-	-	-	-	1404	1405C
14-2	Lower Bearing Retainer	1453	1453	1453	1453	1453	1453
17	Rotor w/ Shaft, 3PH	1708CX	1709CX	1710CX	1711CX	1715CX	1716CX
18	Stator w/ Casing 208V, 3PH	200527	200531	200535	200539	200668	-
18	Stator w/ Casing 230/460V, 3PH	200549	200553	200557	200561	200565	200569
18	Stator w/ Casing 575V, 3PH	200591	200595	200599	200603	200608	200612
20	Upper Ball Bearing	2002	2002	2004	2004	2005	2005
20-1	O-Ring (Kit Only)	-	-	-	-	Kit	Kit
21A	Oil Chamber/Motor Housing	752PX	752PX	753PX	753PX	722CX	714CX
21A-1	O-Ring (Kit Only)	Kit	Kit	Kit	Kit	Kit	Kit
26	Pump Top Cover (W/ Sensor opening)	2670BX	2670BX	2671PX	2671PX	2672BX	2672BX
26-1	O-Ring (Kit Only)	Kit	Kit	Kit	Kit	Kit	Kit
27	Power Cable w/ Gland- 3PH(high temp)	2722F	2722F	2731XF	2731XF	2731XF	2731XF
27-1	O-Ring (Kit Only)	Kit	Kit	Kit	Kit	Kit	Kit
27-2	Seal Minder/Temp. Sensor Cord (high temp)	2736BXF	2736BXF	2736BXF	2736BXF	2736BXF	2736BXF
27-2-1	O-Ring Kit Only	Kit	Kit	Kit	Kit	Kit	Kit
31D	Seal Minder Sensor w/Wire and Ring Term.	2330	2330	2330	2330	2330	2330
31E	Ground Wire w/Ring Term.	2776	2776	2776	2776	2776	2776
32	Power Cord Line Clip / Strain Relief	3200	3200	3216	3217	3208	3208

33	Oil Sensor Cord Line Clip	3203	3203	3203	3203	3203	3203
34	Handle / Chain Handle	3420	3420	3413X	3413X	3418X	3418X
35	Rod Bolts	4120	4121	4122	4123	4109	4110
38	Discharge Nipple 2"	3802X	-	-	-	-	-
38	Discharge Nipple 3"	-	3804X	3804X	3804X	-	-
38E	Discharge Elbow	3831PX	3820PX	3820PX	3820PX	3821CX	3821CX
38E-1	O-Ring, Discharge Elbow FKM	5127V	5128V	5128V	5128V	-	-
38E-1	Gasket, Discharge Elbow FKM	-	-	-	-	4073V	4073V
38F	Discharge Flange 2"	3822PX	-	-	-	-	-
38F	Discharge Flange 3"	-	3810PX	3810PX	3810PX	-	-
38F	Discharge Flange 4"	-	-	3816PX	3816PX	3806CX	3806CX
38F-1	O-Ring, 2" Discharge Flange FKM	5125V	-	-	-	-	-
38F-1	O-Ring, 3" Discharge Flange FKM	-	5126V	5126V	5126V	-	-
38F-1	O-Ring, 4" Discharge Flange FKM	-	-	5129V	5129V	-	-
38F-1	Gasket, 4" Discharge Flange FKM	-	-	-	-	4073V	4073V
50-01-2	Bolt for Strainer/Stand	5013	5013	5013	5013	5014	5014
50-02	Bolt for Suction Cover	-	-	-	-	5014	5014
50-07	Screw for Oil Chamber/Motor Housing	5097	5097	5097	5097	5014	5014
50-08	Screw for Oil Chamber Cover	5009	5009	5009	5009	5034	5034
50-11	Screw for Oil Fill	5008	5008	5008	5008	5008	5008
50-11-1	O-Ring (Kit Only)	Kit	Kit	Kit	Kit	Kit	Kit
50-12	Screw for Pressure Check	5008	5008	5008	5008	5008	5008
50-12-1	O-Ring (Kit Only)	Kit	Kit	Kit	Kit	Kit	Kit
50-14-2	Screw for Bearing Retainer	5009	5009	5009	5009	5009	5009
50-27	Screw for Power Cord	5095	5095	5034	5034	5034	5034
50-27-2	Screw for Oil Sensor Cord	5095	5095	5095	5095	5095	5095
50-31E	Screw for Ground Wire	5000	5000	5000	5000	5000	5000
50-32/50-33	Screw for Line Clip	5001	5001	-	-	-	-
50-34	Screw for Handle	5009	5009	-	-	-	-
50-34-3	Lock Washer	-	-	-	-	402	402
50-38E	Bolt for Discharge Elbow	5093	5061	5061	5061	5079	5079
50-38F	Bolt for Discharge Flange	5014	5093	5093	5093	5081	5081
	O-Ring Kit - FKM	4046PV	4046PV	4044PV	4044PV	4045CV	4045CV



THREE PHASE WIRING DIAGRAMS

208V

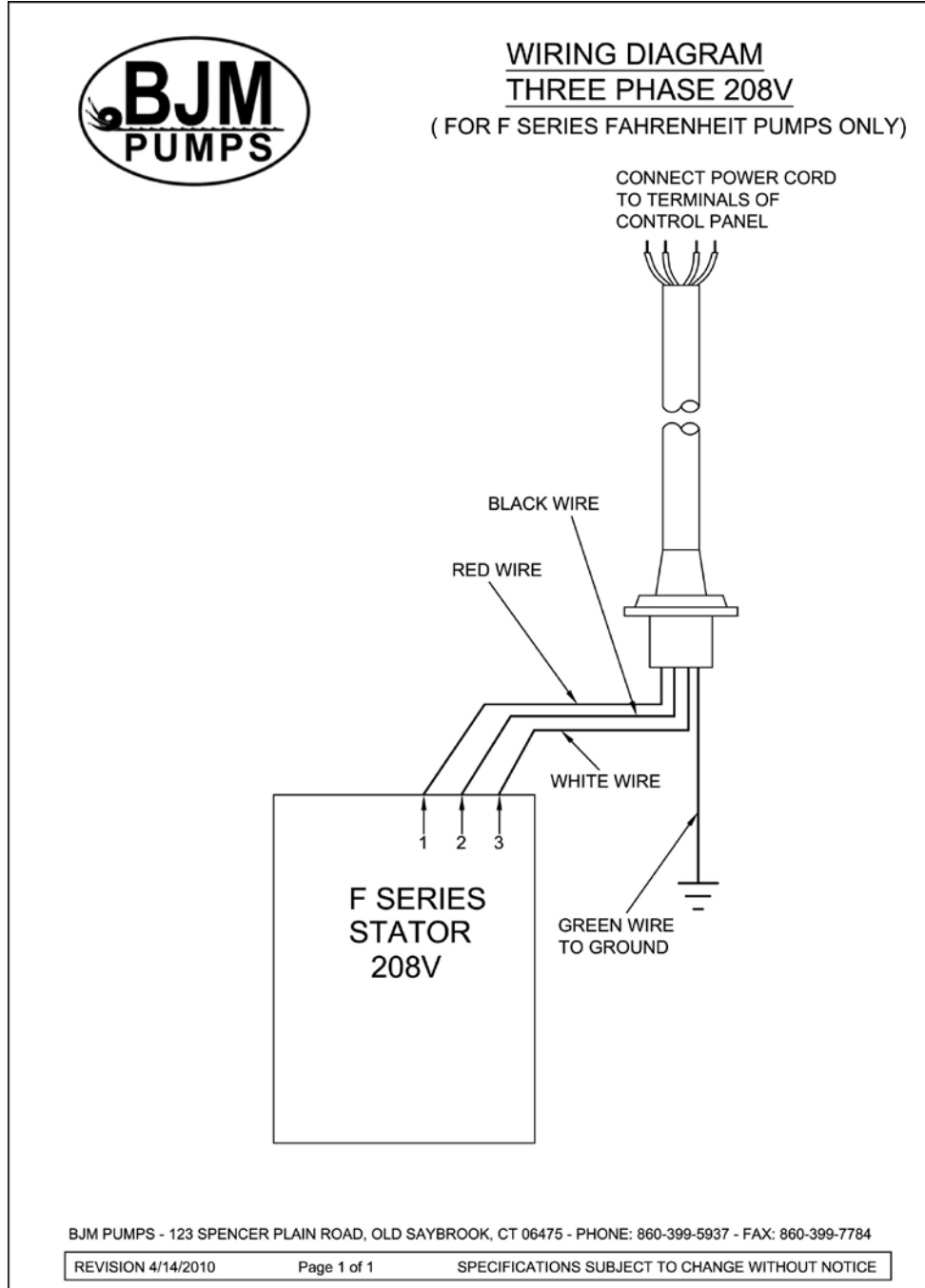

MODELS S08C-F, SX08CSS-F, S15C-F, SX15CSS-F, S22C-F, SX22CSS-F, S37C-F, SX37CSS-F,
S55C-F, SX55CSS-F, S75C-F, SX75CSS-F



230V

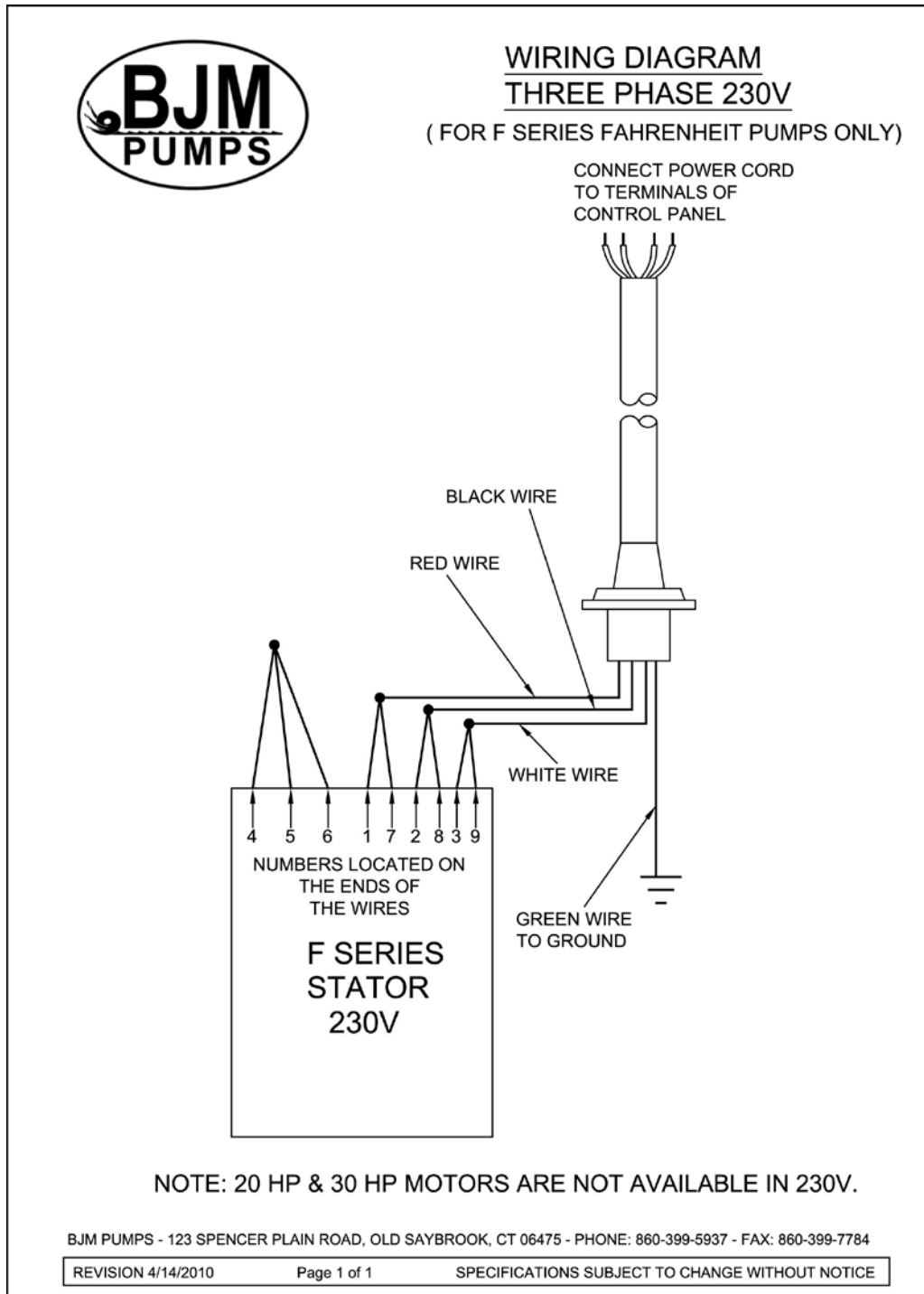

MODELS S08C-F, SX08CSS-F, S15C-F, SX15CSS-F, S22C-F, SX22CSS-F, S37C-F, SX37CSS-F,
S55C-F, SX55CSS-F, S75C-F, SX75CSS-F



460V

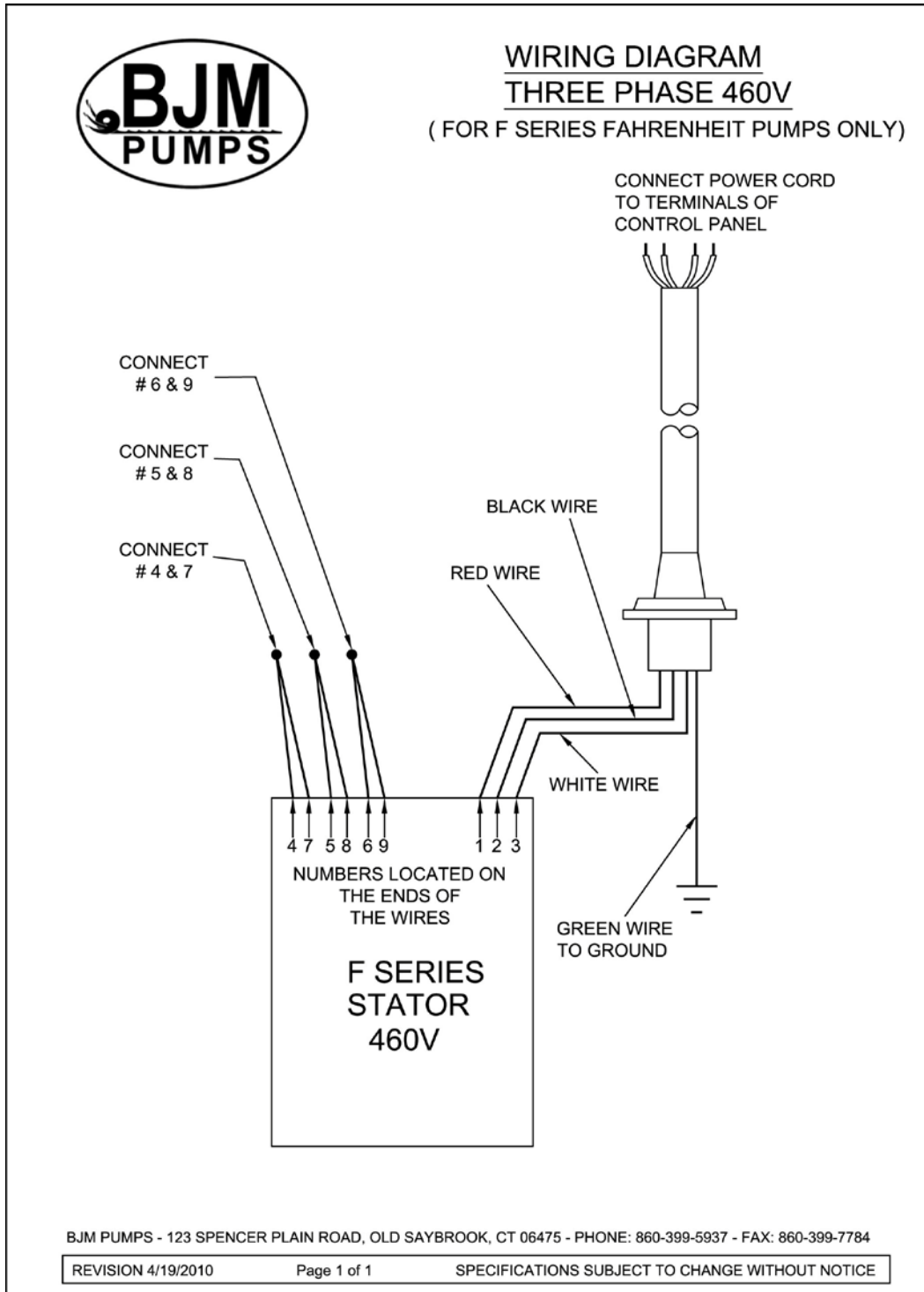

MODELS S08CF, SX08CSS-F, S15C-F, SX15CSS-F, S22C-F, SX22CSS-F, S37C-F, SX37CSS-F, S55C-F, SX55CSS-F, S75C-F, SX75CSS-F



575V

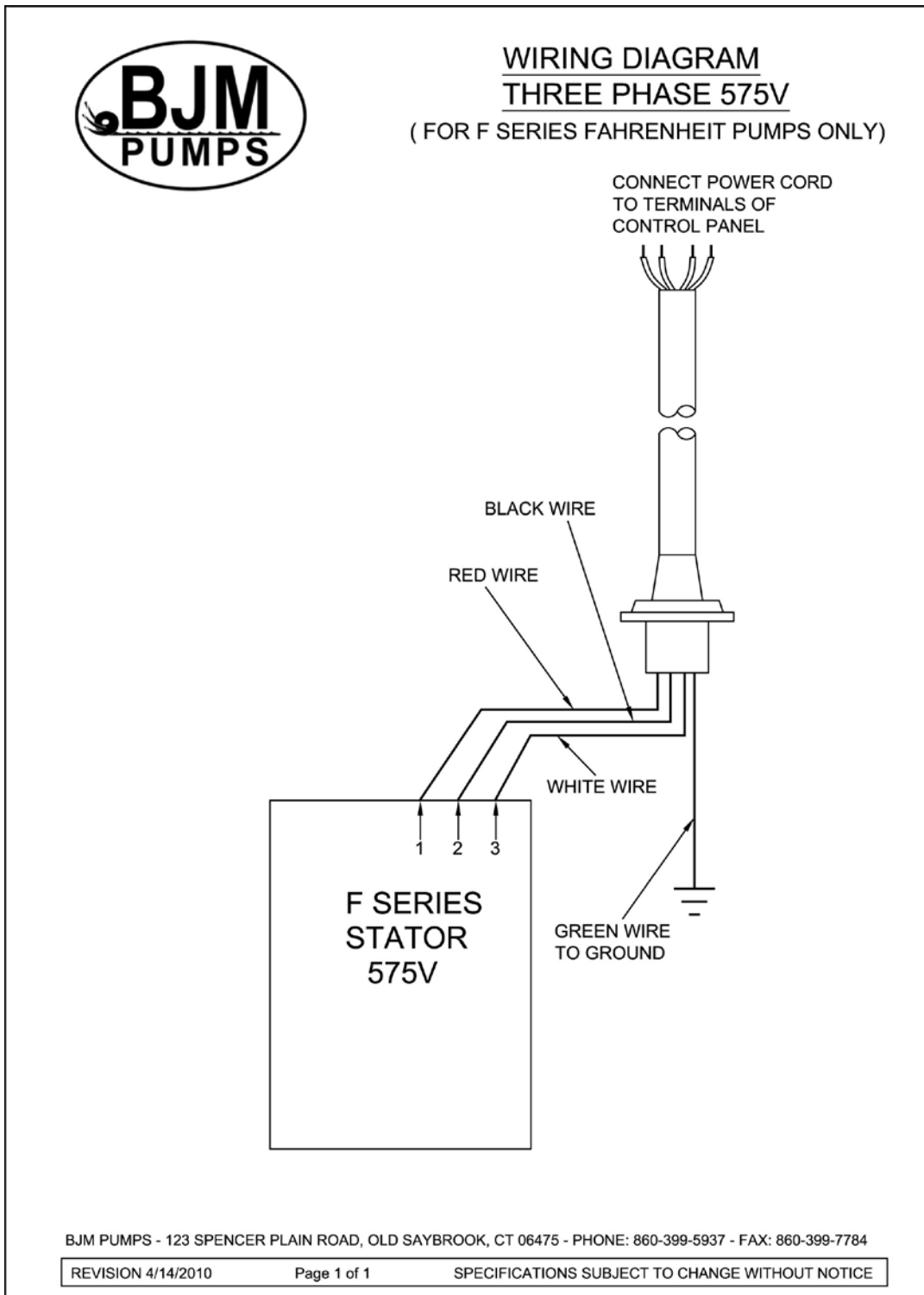

MODELS S08C-F, SX08CSS-F, S15C-F, SX15CSS-F, S22C-F, SX22CSS-F, S37C-F, SX37CSS-F, S55C-F, SX55CSS-F, S75C-F, SX75CSS-F



SEAL MINDER® - THERMAL MOTOR SENSOR SWITCH

(For high temperature pump models)

Seal Minder:

Also known as a seal failure circuit (or moisture detection circuit) is designed to inform the pump operator that there is moisture within the oil chamber. This early warning can allow the operator to schedule repair & inspection on the pump. The **Seal Minder** sensor probe is inside the oil chamber. (The oil chamber houses the mechanical seals that are cooled & lubricated by oil). The **Seal Minder**, when properly connected to a control panel, can help indicate seal failure. The **Seal Minder** cord requires a seal fail circuit in control panel for warning signal.

Along, with the **Seal Minder**, the **FAHRENHEIT**™ Series high temperature pumps also feature thermal temperature sensor switches that are imbedded into the motor stator windings. Three switches are imbedded into the stator windings and wired in series. The leads are connected to the pump control panel through the sensor cable. If the windings would see a temperature above 300 degrees F, then the switch(s) would open and cut power to the pump. Once the temperature dropped below 300 degrees F, the switch(s) would reset, and the pump would be returned to a state of operation. This feature is designed to prevent damage to the stator winding and allow for longer pump life.

The sensor cable consists of four leads, two are connected to the **Seal Minder**, and two are connected to the thermal sensor switches located in the stator windings. These four leads run to the pump control panel and connect to the proper connections points for seal alarm and thermal cut off. The black and white wires are for the **Seal Minder** connections and the seal sensors will be connected to the yellow and red wires. The three phase automatic wiring diagram shown earlier in the manual will give a guide to the connections in the control panel. The manual for the control panel should be consulted for the exact connections.

The sensor cable with **Seal Minder** and thermal sensor switch connections is standard on all **FAHRENHEIT**™ Series high temperature pumps. The cable is designed for a high temperature environment. The proper replacement part can be found parts list found in this manual. BJM Pumps, can supply a control with the Seal Minder and Thermal sensor switch option. Separate stand alone Seal Minder alarm panels are also available. Consult your BJM Pumps representative for part numbers and ordering details. BJM Pumps requires the **Seal Minder** and thermal sensor switches be used. Failure to connect or misuse of these devices will void warranty.

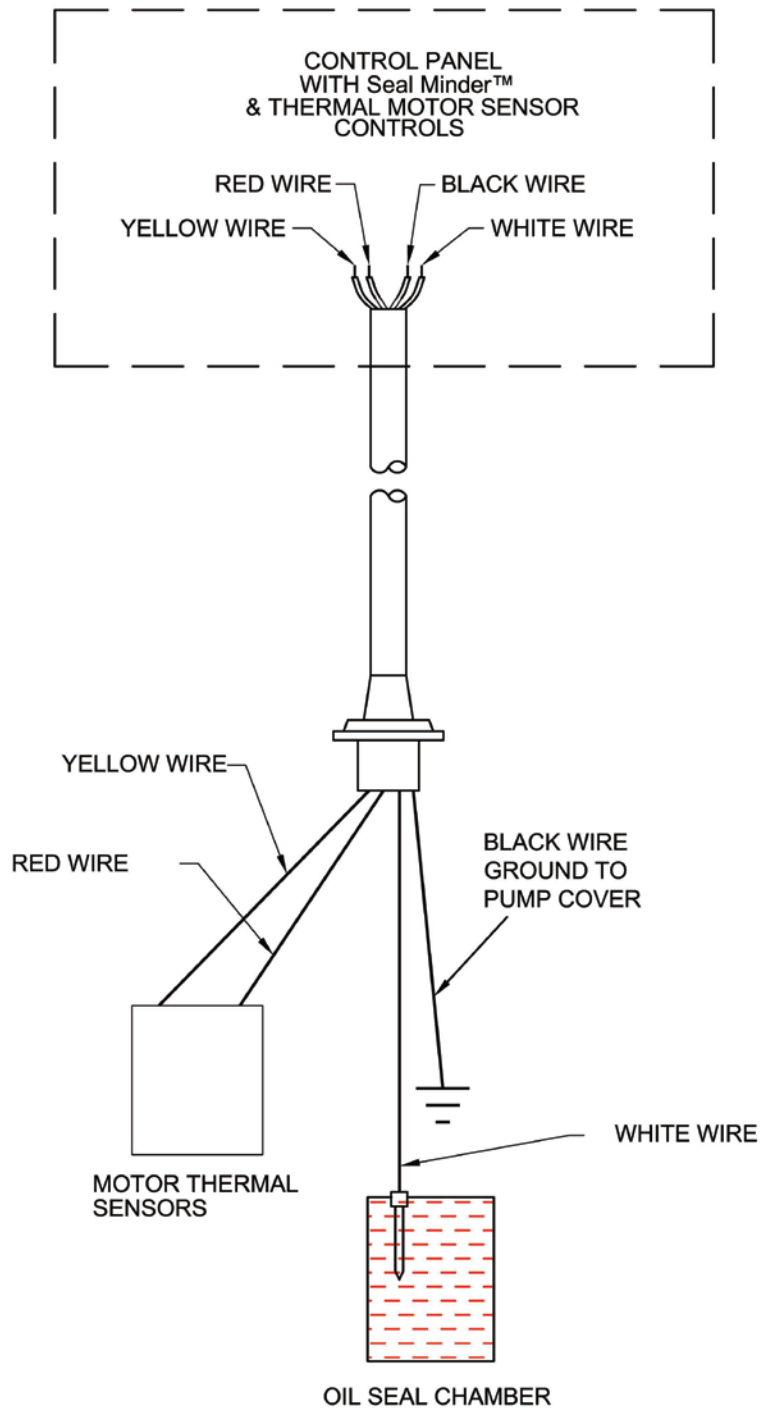

SPECIFICATIONS SUBJECT TO CHANGE WITHOUT NOTICE.

BJM Pumps, LLC - 123 SPENCER PLAIN ROAD, OLD SAYBROOK, CT 06475 - PHONE: 860-399-5937 - FAX: 860-399-7784

BJM PUMPS, LLC
123 Spencer Plain Road
Old Saybrook, CT 06475, U.S.A.

WARRANTY AND LIMITATION OF LIABILITY

Unless otherwise expressly authorized in writing, specifying a longer or shorter period, BJM Pumps, LLC warrants for a period of eighteen (18) months from the date of shipment from the Point of Shipment, or one (1) year from the date of installation, whichever occurs first, that all products or parts thereof furnished by BJM Pumps, LLC under the brand name **BJM Pumps**, hereinafter referred to as the "Product" are free from defects in materials and workmanship and conform to the applicable specification.

BJM Pumps, LLC's liability for any breach of this warranty shall be limited solely to replacement or repair, at the sole option of BJM Pumps, LLC, of any part or parts of the Product found to be defective during the warranty period, provided the Product is properly installed and is being used as originally intended. Any breach of this warranty must be reported to BJM Pumps, LLC or BJM Pumps, LLC's authorized service representative within the aforementioned warranty period, and defective Product or parts thereof must be shipped to BJM Pumps, LLC or BJM Pumps, LLC's authorized representative, transportation charges prepaid. Any cost associated with removal or installation of a defective Product or part is excluded.

IT IS EXPRESSLY AGREED THAT THIS SHALL BE THE SOLE AND EXCLUSIVE REMEDY OF BJM PUMPS, LLC'S DISTRIBUTORS AND CUSTOMERS. UNDER NO CIRCUMSTANCES SHALL BJM PUMPS, LLC BE LIABLE FOR ANY COSTS, LOSS, EXPENSE, DAMAGES, SPECIAL DAMAGES, INCIDENTAL DAMAGES OR CONSEQUENTIAL DAMAGES ARISING DIRECTLY OR INDIRECTLY FROM THE DESIGN, MANUFACTURE, SALE, USE OR REPAIR OF THE PRODUCT, WHETHER BASED ON WARRANTY, CONTRACT, NEGLIGENCE, OR STRICT LIABILITY. IN NO EVENT WILL LIABILITY EXCEED THE PURCHASE PRICE OF THE PRODUCT.

THE WARRANTY AND LIMITS OF LIABILITY CONTAINED HEREIN ARE IN LIEU OF ALL OTHER WARRANTIES AND LIABILITIES, EXPRESSED OR IMPLIED. ALL IMPLIED WARRANTIES OF MERCHANTABILITY AND FITNESS FOR A PARTICULAR PURPOSE ARE HEREBY DISCLAIMED BY BJM PUMPS, LLC AND EXCLUDED FROM THIS WARRANTY.

BJM Pumps, LLC neither assumes, nor authorizes any person to assume for it, any other warranty obligation in connection with the sale of the Product. This warranty shall not apply to any Product or parts of Product which have (a) been repaired or altered outside of BJM Pumps, LLC's facilities unless such repair was authorized in advance by BJM Pumps, LLC or by its authorized representative; or (b) have been subject to misuse, negligence or accident; or (c) have been used in a manner contrary to BJM Pumps, LLC's instruction.

In any case of products not manufactured and sold under the BJM Pumps, LLC brand name, there is no warranty from BJM Pumps, LLC; however BJM Pumps, LLC will extend any warranty received from BJM Pumps, LLC's supplier of such products.

START-UP REPORT FORM

START-UP REPORT FORM

This form is designed to record the initial installation, and to serve as a guide for troubleshooting at a later date (if needed).

BJM Pumps, LLC
 123 Spencer Plain Road
 Old Saybrook, CT. 06475

Pump Owner's Name			
Location of Installation		Date of Installation:	
Dealer		Dealer Phone ()	
Date of Purchase			
Model		Serial No	
Voltage	Phase	Hertz	HP
Does impeller turn freely by hand?		<input type="checkbox"/> Yes	<input type="checkbox"/> No
Condition of Equipment		<input type="checkbox"/> New	<input type="checkbox"/> Good <input type="checkbox"/> Fair <input type="checkbox"/> Poor
Condition of Cable Jacket		<input type="checkbox"/> New	<input type="checkbox"/> Good <input type="checkbox"/> Fair <input type="checkbox"/> Poor
Rotation: Direction of Impeller Rotation (viewed from bottom) (Use C/W for clockwise, CC/W for counterclockwise): _____			
Resistance of cable and Pump Motor (measured at pump control)			
Red-Black_____ohms		Red-White_____ohms	
White-Black_____ohms			
Resistance of ground circuit between control panel and outside of pumps _____ Ohms			
MEG OHM CHECK OF INSULATION			
Red to ground_____		White to ground_____	
Black to ground_____			
Condition of location at start-up		<input type="checkbox"/> Dry	<input type="checkbox"/> Wet <input type="checkbox"/> Muddy
Was equipment stored		<input type="checkbox"/> Yes	<input type="checkbox"/> No.
If YES, length of storage:			
Liquid being pump			
Debris in bottom of station?		<input type="checkbox"/> Yes	<input type="checkbox"/> No

START-UP REPORT FORM

Are guide rails vertical?	<input type="checkbox"/> Yes	<input type="checkbox"/> No
Is base elbow installed level?	<input type="checkbox"/> Yes	<input type="checkbox"/> No
Liquid level controls: Model _____		
Is control installed away from turbulence?	<input type="checkbox"/> Yes	<input type="checkbox"/> No
Float Operation Check		
Tip lowest float (stop float), all pumps should remain off. Tip second float (and stop float), one pump comes on. Tip third float (and stop float), both pumps on (alarm on simplex). Tip fourth float (and stop float), high level alarm on (omit on simplex).		
<input type="checkbox"/> Check here if using manual on/off only.		
Does liquid level ever drop below volute top?	<input type="checkbox"/> Yes	<input type="checkbox"/> No
Control Panel MFG & model no.		
Number of pumps operated by control panel		
NOTE: At no time should hole be made in top of control panel, unless proper sealing devices are utilized.		
Short Circuit protection:	Type:	
Number and size of short circuit device(s)	Amp rating:	
Overload type:	Size:	Amp rating:
Do protective devices comply with pump motor amp rating?	<input type="checkbox"/> Yes	<input type="checkbox"/> No
Are all pump connections tight?	<input type="checkbox"/> Yes	<input type="checkbox"/> No
Is the interior of the panel dry?	<input type="checkbox"/> Yes	<input type="checkbox"/> No If No, correct moisture problem.
Electrical readings		
SINGLE PHASE		
Voltage supply at panel line connection, pump off	L1	L2
Voltage supply at panel line connection, pump on	L1	L2
Amperage load connection, pump on	L1	L2
THREE PHASE		
Voltage supply at panel line connection, pump off		
L1-L2	L2-L3	L3-L1
Voltage supply at panel line connection, pump on		

START-UP REPORT FORM

L1-L2	L2-L3	L3-L1
Amperage load connection, pump on		
L1	L2	L3
FINAL CHECK		
Is pump secured properly?	<input type="checkbox"/> Yes	<input type="checkbox"/> No
Was pump checked for leaks?	<input type="checkbox"/> Yes	<input type="checkbox"/> No
Do check valves operate properly?	<input type="checkbox"/> Yes	<input type="checkbox"/> No
Flow: Do pumps appear to operate at proper rate?	<input type="checkbox"/> Yes	<input type="checkbox"/> No
Noise level:	Acceptable <input type="checkbox"/>	Unacceptable <input type="checkbox"/>
Comments:		
Installed by:		
Company:		
Person:		
Date:		

BJM Pumps, LLC
123 Spencer Plain Road • PO Box 1138 • Old Saybrook, CT 06475, USA
• Phone: (860) 399-5937 • Fax: (860) 399-7784
Email: sales@bjmpumps.com • Web Site: www.bjmpumps.com

FARMENHET[™] is a trademark of BJM Pumps, LLC.
BJM Pumps & Seal Minder is a registered trademark of BJM Pumps, LLC
Copyright © 2009-2011 BJM Pumps, LLC. All rights reserved