



ITT

B3/5AB2

Residential & Commercial Water Systems

CentriPro

Aquavar ABII

3AB2, 5AB2

 Variable Speed Constant Pressure Pump Controllers

FEATURES

- **Input Power^①:** 196-264 Volts, single phase 2-wire, grounded
- **Output Power:** Up to 230V three phase (based on input voltage). Motor rated for 208-230 V.
- **Input Controls:** Press and hold pressure increase/decrease buttons. Minimum speed and motor overload switch.
- **Signal Light:** Power on, pump running, pump stopped, faults/errors.
- **Electrical Efficiency:** Over 95%
- **Protection Against:** Short circuit, over/under voltage, motor overload, dead heading, suction loss, sensor fault, bound pump, over/under temperature.
- **Ambient Temperature:** 14° F to 122° F
- **Maximum Humidity:** 95% at 122° F, non-condensing
- **Enclosure:** NEMA 3R, IP 22 (Rain-tight)
- **Mounting:** Mount vertically, screws included
- **Cooling:** Convection with heat sink and fan
- **Transducer:** 0.5 - 4.5 VDC with 5 VDC power supply, 10' 3-wire cable.

① Low input voltage will affect motor operation.



CentriPro is a brand of ITT Corporation.

www.centripro.com

Engineered for life

PRODUCT OVERVIEW

Think of it as “Cruise Control” for your pump.

The Aquavar ABII pump controller provides an economical answer for municipal and private water systems with low water pressure. Both domestic and light commercial above ground boosters can benefit. As water use increases, the controller changes pump speed to maintain pressure. Large supply tanks are eliminated and up to 50% of the energy required by a full speed pump is saved.

CONTROLLER MODEL NUMBERS AND AMPERAGE / HP RANGES

- **3AB2** – 10.0 maximum amps, 3 HP, 230V, 3Ø Motors
- **5AB2** – 16.6 maximum amps, 5 HP, 230V, 3Ø Motors

SPECIFICATIONS

Controller Temperature Range:

- Minimum Ambient Temperature: 14° F (-10° C)
- Maximum Ambient Temperature: 122° F (50° C)

Input Voltage: 196 - 264 Volts, 1Ø, 2-Wire Grounded

Output Voltage: Up to 230V, 3Ø based on input voltage

Enclosure Dimensions:

- Height: 18.6"
- Width: 9.9"
- Depth: 5.3"

Packaged Dimensions:

- Height: 21"
- Width: 13"
- Depth: 8"

3AB2 Specifications:

- Amperage / HP Range: 10.0A / 3 HP maximum
- Unit Weight: 21 lbs.
- Packaged Weight: 23 lbs.
- Pressure Set Point: adjustable from 20 - 85 PSI with 100 PSI transducer
- Includes: 100 PSI Transducer, 10' Transducer Cable, Mounting Screws and Ground Clamp

5AB2 Specifications:

- Amperage / HP Range: 16.6A / 5 HP maximum
- Unit Weight: 22 lbs.
- Packaged Weight: 24 lbs.
- Pressure Set Point: adjustable from 20 - 100 PSI with 200 PSI transducer
- Includes: 200 PSI Transducer, 10' Transducer Cable, Mounting Screws and Ground Clamp

3AB2 AND 5AB2 PRESSURE RANGE DATA

Transducer	3AB2		5AB2	
	Minimum PSI	Maximum PSI	Minimum PSI	Maximum PSI
100 PSI ①	20	85	—	—
200 PSI ②	40	170	20	100

① Standard on 3AB2

② Standard on 5AB2

- Maximum system pressure for 3AB2 with 100 PSI Transducer is 85 PSI
- Maximum system pressure for 5AB2 with 100 PSI Transducer is 100 PSI
- System Pressure is Suction (Incoming) Pressure plus Pump "boost" Pressure. A pump that produces 50 PSI at 10 GPM with 30 PSI of suction pressure will provide 10 GPM at 80 PSI (50 + 30) System Pressure.

Complete Systems: pump with pre-wired controller, transducer with cable and tank tee are available. See Aquavar ABII Systems Bulletin, BAQUABII for data and variable speed curves.

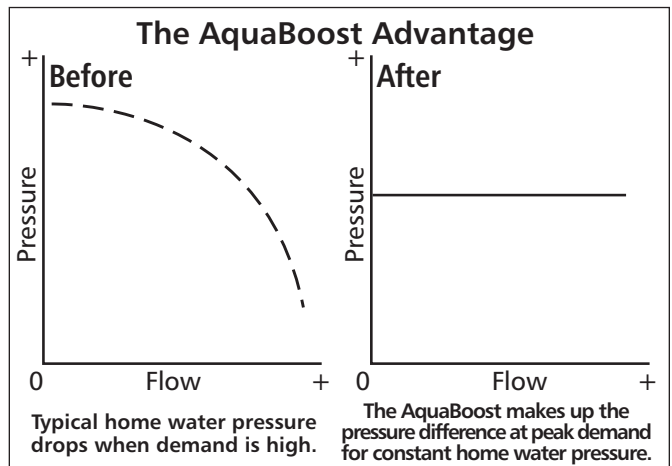

AGENCY LISTINGS



Tested to UL508C and
CSA 22.2 #14
Standards By Canadian
Standards Association
File #LR38549

Goulds Pumps is ISO 9001 Registered.

3AB2 UIB

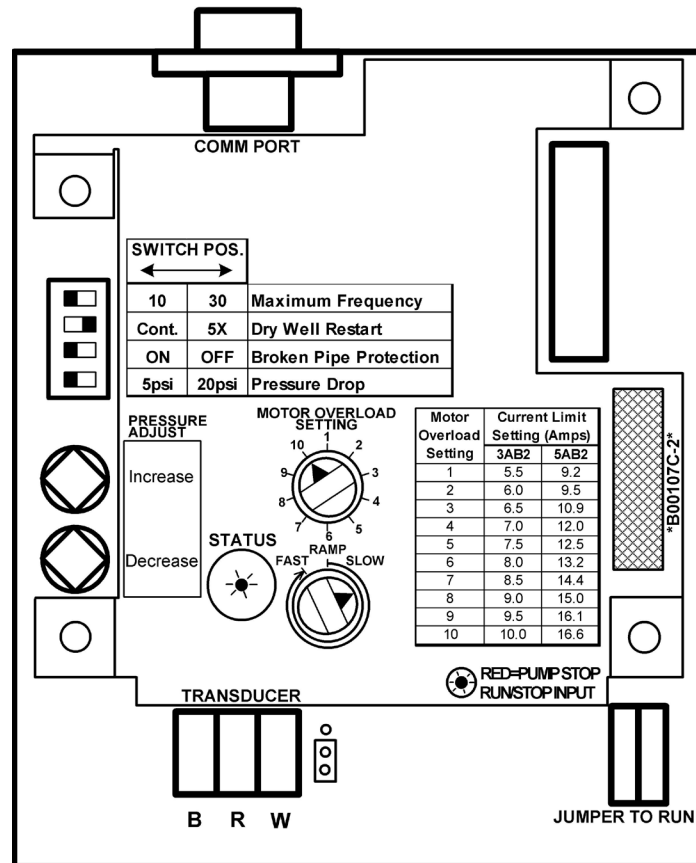

DIMENSIONS - 3AB2 AND 5AB2

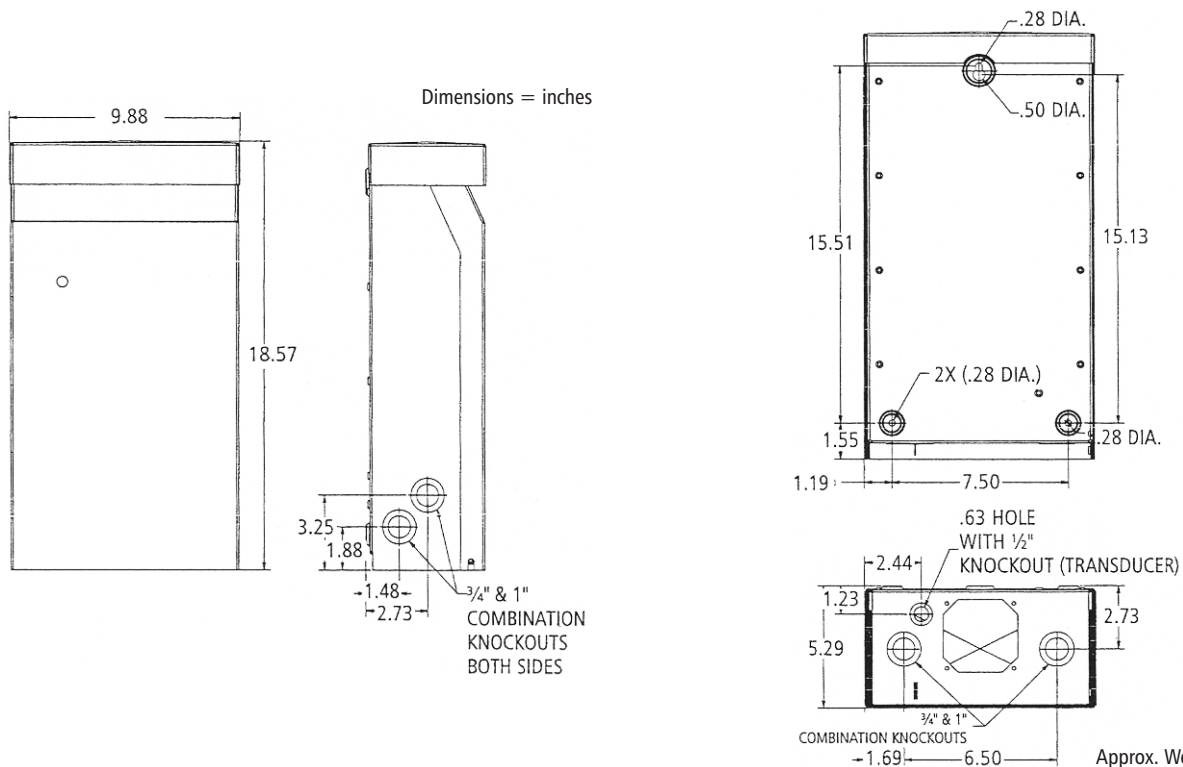

TYPICAL SYSTEM INSTALLATIONS

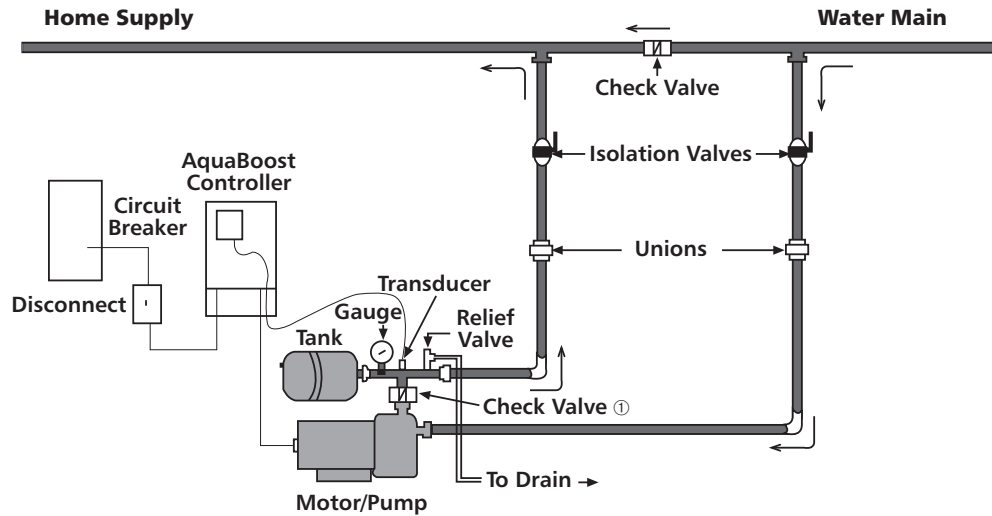

Figure 1
System Layout
for municipal hook-up

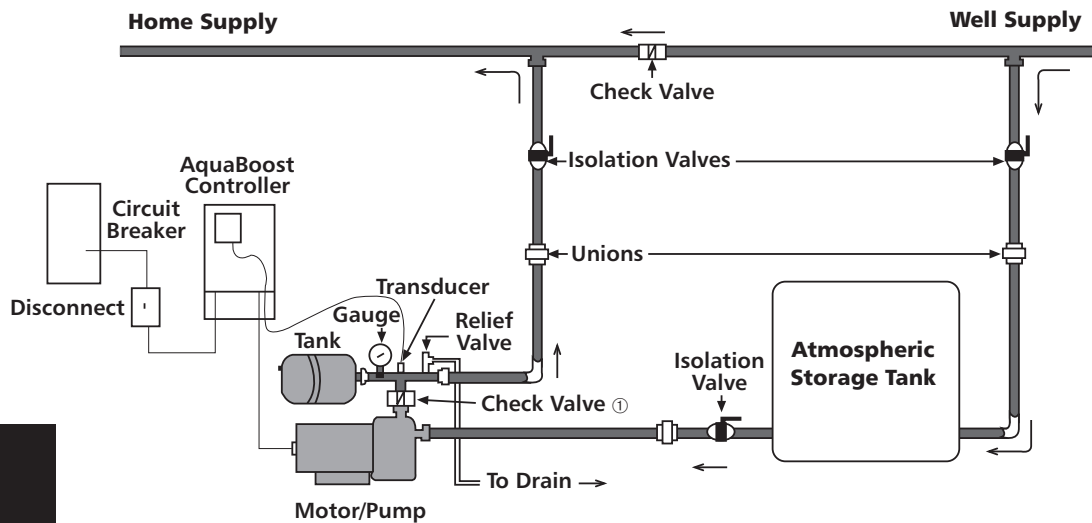

Figure 2
System Layout for
supply tank

① Installing the check valve on the discharge side of pump will allow faster turn off at no flow.

Note: Fittings and valves are not included with AquaBoost controllers.



ITT
2881 East Bayard Street, Seneca Falls, NY 13148
Phone: (315) 568-7123 • Fax: (315) 568-7973
www.centripro.com

CentriPro is a registered trademark of ITT Corporation.
ITT, the Engineered Blocks Symbol and Engineered for Life are registered trademarks of ITT Manufacturing Enterprises, Inc.

Copyright © 2010 ITT Corporation B3/5AB2 December, 2010 Printed in U.S.A.
SPECIFICATIONS ARE SUBJECT TO CHANGE WITHOUT NOTICE.

