

# DUPLEX NEMA 4X WEATHERPROOF PANELS

Single and Three Phase Control Panels

## FEATURES

NEMA 4X, 30 watt, flashing red light and alarm horn – 95db.

NEMA 4X, fiberglass enclosure with gasketed, hinged door and stainless steel hardware.

### Single Phase

Field adjustable for 115 or 230V, 60 Hz.  
2 pump circuit breakers.

### Three Phase

Field adjustable for 208/230 /460/575V, 60 Hz.  
115V control circuit transformer.  
2 adjustable motor overload protectors.  
Heaters not required.

Provides fully automatic operation for two pumps.

Solid state pump alternator circuit displays float status for ease of installation and trouble shooting.

Entire unit is UL and CUL listed.



## Wastewater

### APPLICATIONS

Superior quality duplex liquid level controller, automatic alternation for two pump operation. High level alarm warning designed for a variety of sump, effluent, sewage and water transfer applications.

### SPECIFICATIONS

- Accepts single or dual power feed.
- 2 hand-off-automatic (H-O-A) pump switches.
- On-off control circuit switch.
- 2 oversized magnetic contactors.
- Numbered terminal strip-screw type.
- **Float Switches** – **Note:** Please order float switches separately. We offer several types and models. See the Float Switch bulletin for available options. The type selected determines the quantity needed. The basin depth and panel location determine the required cord length. Contact your distributor or Customer Service for additional information.
- Electronic pump alternator.
- Alternator selector switch
- Lag pump start delay

### FEATURES

- Rugged NEMA 4X construction withstands even the most severe weather conditions and prevents corrosion.
- Provides fully automatic operation for two pumps. Alternates pump starting to distribute operating time. Provides extra pumping capacity in times of high inflow by energizing both pumps.
- Alternator selector toggle for maintenance on one or both pumps.
- Hinged door with lockable stainless steel latch for safe operation indoors or out.

- High level alarm circuit includes through door mounted silence switch for manual silence of alarm horn.
- Through door mounted alarm test switch insures proper operation of the alarm circuit without the need to open the panel.
- 2 through door mounted pump run lights.
- Top mounted high intensity flashing red light provides 360° visibility.
- Pulsating, corrosion proof alarm horn.
- These duplex controls are factory wired for operation with three float bulbs. An easy field modification for four float bulb operation using separate “lag-on” and “alarm bulbs” is provided.
- Alternator selector switch allows a choice of automatic alternation or operation of only pump 1 or pump 2. Typically used if one pump is down for maintenance.
- Lag pump start delay built-in. Delays starting lag pump for 5 seconds if both pumps attempt to start simultaneously as after a power outage.
- Panel can be wired for a single power feed for pumps and control circuit or the control circuit can be wired to a separate power supply to insure alarm integrity in case of a tripped main breaker.
- Auxiliary alarm contacts provided for remote alarm connection.
- Color coded wiring, screw type terminals and plug in sockets, ensure ease of field servicing.
- Field wiring diagram, panel schematic and installation instructions included.
- Requires three float switches or with optional fourth lag float, order separately.

### PANEL MODEL INFORMATION

SINGLE PHASE PANELS		THREE PHASE PANELS	
ORDER NUMBER	AMP RANGE	ORDER NUMBER	AMP RANGE
D10020	0-20	D31625	1.6 - 2.5
D12127	21-27	D32540	2.5 - 4.0
D12836	28-36	D34063	4.0 - 6.3
		D36310	6.3 - 10
		D31016	10 - 16
		D31620	16 - 20
		D32025	20 - 25
		D32232	22 - 32

### ADDITIONAL OPTIONS

**Code** (add as required)

- A = Guaranteed pump submergence circuit
- C = 115V condensation heater
- D = Single phase lightning arrestor
- E = Three phase lightning arrestor
- G = Elapsed time meter (2) – Duplex
- J = Seal fail circuit (2) – Duplex
- L = Cycle counter (2) – Duplex
- N = High temp. indicator with pump shutdown – Duplex

P = Special duplex Mini CAS seal fail and high temperature circuit for use on only three phase 15/20GD, 15/20GX and 1GA/2GA pumps. **For single phase**, see CentriPro single phase grinder control panels bulletin BCP1PGP for standard, BCP1PC1P for explosion proof.

T = 4 intrinsically safe relays in duplex panel

YY = Duplex dry contact for seal failure interface to building management system.

ZZ = Duplex dry contact for pump running interface to building management system.

When ordering options, add the appropriate code number as a suffix to the panel order number.

Example...D31625CG adds a condensation heater and (2) elapsed time meters.

### ENCLOSURE DIMENSIONS (in inches)

Single Phase						
A	B	C	D	E	F	G
10.1	15.5	18.3	14.8	6.8	7.2	13.3
Three Phase						
A	B	C	D	E	F	G
12.1	17.5	20.3	16.8	6.8	7.2	15.3
<b>NOTE:</b> Mounting holes are $\frac{3}{8}$ ".						

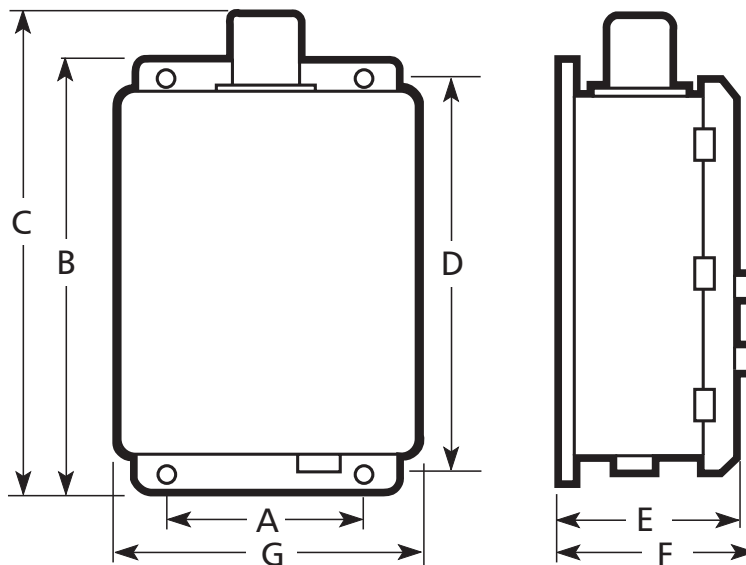

### SINGLE PHASE COMPONENTS

1. NEMA 4X enclosure
2. Flashing alarm light
3. Alarm horn (RB50)
4. Pump run light
5. Alarm silence button
6. Alarm test button
7. Control power on/off switch
8. H-O-A switch
9. Alarm reset button
10. Contactor (RB32)
11. Terminal strip
12. Alternator circuit (RB75)
13. Motor circuit breakers

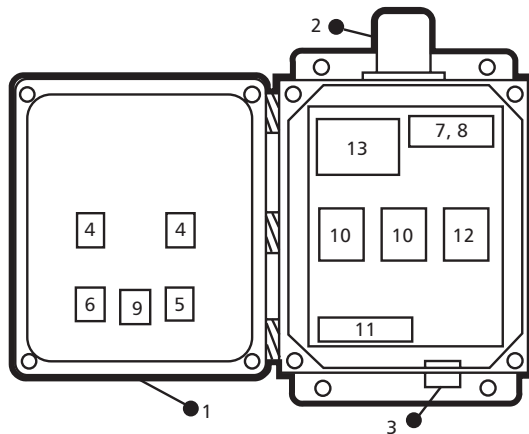

### THREE PHASE COMPONENTS

1. NEMA 4X enclosure
2. Flashing alarm light
3. Alarm horn (RB50)
4. Pump run light
5. Alarm silence button
6. Alarm test button
7. Control power on/off switch
8. H-O-A switch
9. Alarm reset button
10. Contactor (RB47)
11. Terminal strip
12. Alternator circuit (RB75)
13. Control transformer
14. Motor circuit protectors (RB52 through 57)

