

# SIMPLEX WEATHERPROOF CONTROL PANELS

Single and Three Phase Control Panel

## FEATURES

Rugged NEMA 4X construction withstands even the most severe weather conditions and prevents corrosion.

Solid state control board displays float status for ease of installation and troubleshooting.

Hinged door with lockable stainless steel latch for safe operation indoors and out.

High level alarm circuit includes spring loaded through door mounted silence switch for manual silence of alarm horn.

Through door mounted pump run light.

Top mounted high intensity flashing red light provides 360° visibility.

Pulsating, corrosion proof alarm horn.

Auxiliary alarm contacts provided for remote alarm connection.

Entire unit is UL and CUL listed.



## Wastewater

### APPLICATIONS

Superior quality simplex liquid level controller, automatically maintains pump operation, includes high level alarm warning for a variety of sump, effluent, sewage and water transfer applications.

### SPECIFICATIONS

- Accepts single or dual power feed.
- Hand-off-automatic (H-O-A) pump selection switch.
- On-off control circuit switch.
- Oversized magnetic contactor.
- Numbered terminal strip-screw type.
- **Float Switches** – **Note:** Please order float switches separately. We offer several types and models. See the Float Switch bulletin for available options. The type selected determines the quantity needed. The basin depth and panel location determine the required cord length. Contact your distributor or Customer Service for additional information.
- NEMA 4X, 30 watt, flashing red light.
- NEMA 4X, fiberglass enclosure with gasketed, hinged door and stainless steel hardware.
- Solid state printed circuit control board with float indicator lights.
- NEMA 4X, alarm horn – 95db.
- Auxiliary alarm contacts.

### Single Phase

- Field adjustable for 115 or 230 V, 60 Hz.

### Three Phase

- Field adjustable for 208/230/460/575 V, 60 Hz.
- 115V control circuit transformer.
- Adjustable motor overload protectors.
- **Heaters not required.**

### FEATURES

- Through door mounted alarm test switch insures proper operation of the alarm circuit without the need to open the panel.
- Color coded wiring, screw type terminals and plug in sockets, ensure ease of field servicing.
- Field wiring diagram, panel schematic and installation instructions included.
- Panel can be wired for a single power feed for pump and control circuit or the control circuit can be wired to a separate power supply to insure alarm integrity in case of a tripped pump breaker.

### PANEL MODEL INFORMATION

SINGLE PHASE PANELS		THREE PHASE PANELS	
ORDER NUMBER	AMP RANGE	ORDER NUMBER	AMP RANGE
S10020	0-20	S31625	1.6 - 2.5
S12136	21-36	S32540	2.5 - 4.0
		S34063	4.0 - 6.3
		S36310	6.3 - 10
		S31016	10 - 16
		S31620	16 - 20
		S32025	20 - 25
		S32232	22 - 32

### ADDITIONAL OPTIONS

**Code** (add as required)

- A = Guaranteed pump submergence circuit
- C = 115V condensation heater
- D = Single phase lightning arrestor
- E = Three phase lightning arrestor
- F = Elapsed time meter (1) – simplex
- H = Seal fail circuit (1) – simplex
- K = Cycle counter – Simplex
- M = High temp. indicator with shutdown – Simplex

O = Special simplex seal fail and high temperature circuit for use on only three phase 15/20GD, 15/20GX and 1GA/2GA pumps. For **single phase**, see CentriPro single phase grinder control panels bulletin BCP1PGP for standard, BCP1PC1P for explosion proof.

Y = Simplex dry contact for seal failure interface to building management system.

Z = Simplex dry contact for pump running interface to building management system.

When ordering options, add the appropriate code number as a suffix to the panel order number.

Example: S10020CF adds a cond. heater and (1) elapsed time meter.

### ENCLOSURE DIMENSIONS (in inches)

Single Phase						
A	B	C	D	E	F	G
6.3	11.5	14.3	10.8	5.5	6.0	9.3
Three Phase						
A	B	C	D	E	F	G
8.3	13.5	16.3	12.8	5.6	6.1	11.3
<b>NOTE:</b> Mounting holes are $\frac{3}{8}$ ".						

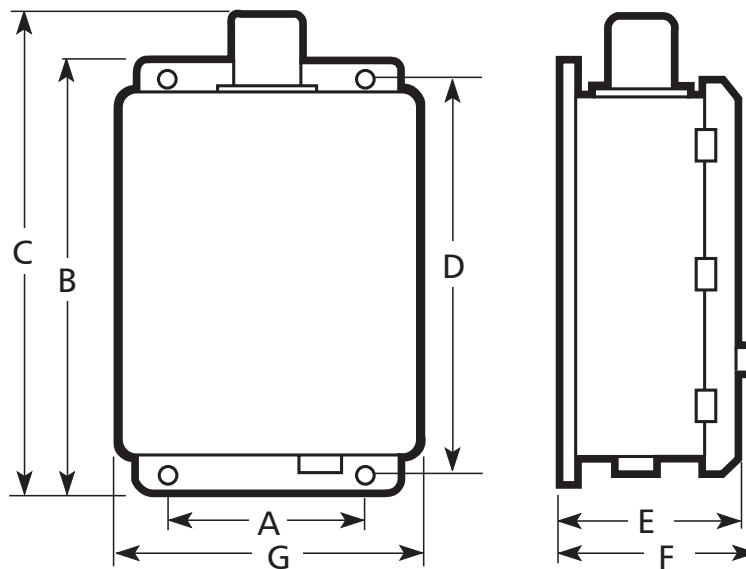

## COMPONENTS

1. NEMA 4X fiberglass enclosure
2. Flashing red alarm light
3. Alarm horn
4. Pump run light
5. Alarm test button
6. Alarm horn silence button
7. Control power on/off switch
8. H-O-A selector switch

9. Contactor
10. Terminal wiring strip – power and pumps
11. Terminal wiring strip – floats
12. Solid-state control board

### Three phase models only

13. Motor circuit protector-upper left corner
14. Transformer-upper right corner

