

# ITT

IM205

Wastewater

## Vortex Series

Installation, Operation and Maintenance Instructions



*Engineered for life*



## Table of Contents

Introduction and Safety .....	2
Technical Data .....	7
General .....	7
Components.....	7
Start Up Procedures .....	8
Delivery Check.....	4
Oil Level .....	8
Power Supply .....	8
Cable Entry .....	8
Motor Protection.....	8
Motor Check.....	8
Installation Parts.....	9
Direction of Rotation .....	9
Current Check.....	9
Start Frequency .....	10
Minimum and Maximum Submersible Depth .....	10
Installation Options .....	11
Installation - Slide Rail .....	11
Check Point Installation.....	12
Installation - Hard Piped .....	12
Routine Maintenance.....	14
General .....	14
Maintenance Schedule .....	14
Lubricants .....	14
Cable Entry .....	14
Oil Level .....	15
Oil Change.....	15
Motor Housing .....	15
Transportation and Storage.....	16
Seal Fail and High Temperature .....	17
Seal Fail.....	17
High Temperature .....	17
Trouble Shooting .....	18
APPENDIX 1: Cable Connections.....	20
Limited Warranty.....	22

## Owners Information

Complete this information for your records. Model number and serial number may be found on the tag mounted to the motor adapter.

Pump Model Number \_\_\_\_\_

Pump Serial Number \_\_\_\_\_

Control Model Number \_\_\_\_\_

Dealer \_\_\_\_\_

Dealer phone number \_\_\_\_\_

Date of purchase \_\_\_\_\_

Date of installation \_\_\_\_\_

# I. Introduction and Safety

## Introduction

### Foreward

We thank you for choosing an ITT pump, which will undoubtedly serve you both reliably and economically for a long time, providing you observe the Maintenance instructions given in this manual.

The Vortex pump is designed to pump sewage and other solids containing waste water. Proper use and maintenance will prolong the operational life of your ITT pump. This manual contains different warnings and safety instruction. Read this manual properly, so that dangerous situations, physical injury or damage can be avoided. The pump is designed for professional use only. Service and maintenance may only be done by authorized personal, after reading this manual. The pump in basic version may not be used in a potentially explosive atmosphere.

### Description

This manual provides instructions for the Installation, Operation and Maintenance of the Vortex pumps. This manual covers the standard product plus common options that are available.

### Requirement

This manual must be read and understood before installation and start-up. ITT shall not be liable for physical injury, damage or delays caused by a failure to observe the instructions for installation, operation and maintenance contained in this manual.

### Content

This instruction manual covers several different pump models that all have similar power end configurations. Most assembly, disassembly and inspection procedures are the same for all the pumps. However, where there are differences, they are called out separately within the manual. The design, materials and workmanship incorporated in the construction of the pumps makes them capable of giving long, trouble free service. The life and satisfactory service of any mechanical unit, however, is enhanced and extended by correct application, proper installation, periodic inspection, condition monitoring and careful maintenance. This instruction manual was prepared to assist operators in understanding the construction and the correct methods of installing, operating and maintaining these pumps.

### Key Topics

- Technical Data
- Start up Procedures
- Installation Options
- Routine Maintenance
- Transportation and Storage
- Seal Fail and High Temperature
- Trouble Shooting
- Cable Connections

## Safety

It is extremely important that you read, understand, and follow the safety messages and regulations carefully before handling an ITT product. They are published to help prevent

- personal accidents and health problems
- damage to the product
- product malfunction

Observe all safety messages highlighted in other sections of this manual.





A pump is a pressure-containing device with rotating parts that can be dangerous.



**Caution:** You must observe the instructions for installation, operation, and maintenance contained in this manual. Failure to do so could result in physical injury, damage, or delays.

## Safety message levels

Table 1: Definitions

Safety message level	Indication
 <u>Danger:</u>	Indicates a hazardous situation which, if not avoided, will result in death or serious injury.
 <u>Warning:</u>	Indicates a hazardous situation which, if not avoided, could result in death or serious injury.
 <u>Caution:</u>	Indicates a hazardous situation which, if not avoided, could result in minor or moderate injury.
<u>Note:</u>	Indicates a potential situation which, if not avoided, may result in undesirable results or state. Indicates a practice not related to personal injury.
 <u>Electrical Hazard:</u>	Indicates the possibility of electrical risks if directions are not applied in a proper manner.

## Environmental safety

### Preventive measures for the working area

Always keep the pump station clean to avoid and/or discover emissions.

### Recycling guidelines

Always recycle according to the guidelines listed below:

1. Follow local laws and regulations regarding recycling if the unit or parts are accepted by an authorized recycling company.
2. If the first guideline is not applicable then return the unit or parts to the nearest ITT representative.

### Waste and emissions

Observe these safety regulations regarding waste and emissions:

- Dispose appropriately of all waste.
- Handle and dispose of the pumpage in compliance with applicable environmental regulations.
- Clean-up all spills in accordance with safety and environmental procedures.
- Report all environmental emissions to the appropriate authorities.

### Reference for electrical installation

For electrical installation recycling requirements, consult your local electric utility.

## User health and safety

### Safety equipment

Use safety equipment according to the company regulations. The following safety equipment should be used within the working area depending on the fluid being pumped:

- helmet
- safety goggles (with side shields)
- protective shoes
- protective gloves
- gas mask
- hearing protection

---

**Note:** The noise level of the product is lower than 70 dB. However, the noise level of 70 dB may be exceeded in some installations and at certain operating points on the performance curve. Make sure that you understand the noise level requirements in the environment where the pump is installed. Failure to do so may result in hearing loss or violation of local laws.

---

### The working area

Observe these regulations and warnings in the working area:

- Always keep the work area clean.
- Pay attention to the chemical and physical characteristics of the gas and vapors present in hazardous areas.
- Avoid all electrical dangers. Pay attention to the risks of electric shock or arc flash hazards.

### Product and product positioning requirements

Observe these requirements for the product and the product positioning:

- Never operate a pump unless safety devices are installed.
- Three-phase motors must have a properly sized starter with properly sized heaters to provide overload and undervoltage protection. Single-phase motors have built-in overload protectors.
- Never start a pump without the proper priming.
- Never run a pump below the minimum rated flow or with any suction or discharge valve closed.

### Electrical connections

Electrical connections must be made by authorized electricians in compliance with all international, national, state and local rules.

Observe the following regulations and warnings for electrical connections.

- Make sure that the product is isolated from the power supply and can not be energized by mistake. This rule applies to the control circuit as well.
- Make sure that the thermal contacts are connected to a protection circuit according to the product approvals, and that they are in use.

Observe the following regulations for grounding connections.

**Table 2: Grounding**

Grounding regulation	Comment
All electric equipment must be grounded.	This rule applies to pumps and mixers as well as monitoring equipment.

## Precautions before work

Observe the following safety precautions before working with or in connection with the product:

- Make sure that there are no poisonous gases within the work area.
- Provide a suitable barrier around the work area, for example a guard rail.
- Make sure that all safety guards are in place and secure.
- Make sure that the equipment is properly insulated when operating at extreme temperatures.
- Allow all system and pump components to cool before you handle them.
- Make sure that you have a clear path of retreat.
- Make sure that the product cannot roll or fall over and injure people or damage property.
- Make sure that the lifting equipment is in good condition.
- Use a lifting harness, a safety line, and a breathing device as required.
- Make sure that the product has been thoroughly cleaned.
- Make sure that a first-aid kit is close at hand.
- Check the explosion risk before welding or using electric hand tools.

## Precautions during work

Observe the following safety precautions when working with or in connection with the product:

- Never work alone.
- Stay clear of suspended loads.
- Always lift the product by its lifting device.
- Beware of the risk of a sudden start if the product is used with an automatic level control.
- Beware of the starting jerk, which can be powerful.
- Rinse the components in water after disassembling the pump.
- Do not exceed the maximum working pressure of the pump.
- Do not open any vent or drain valves or remove any plugs while the system is pressurized. Ensure that the pump is isolated from the system and that pressure is relieved before you disassemble the pump, remove plugs, or disconnect piping.

- Always bear in mind the risk of:
  - electrical accidents
  - burn injuries

## Clean chemicals from the eyes

1. Forcibly hold the eyelids apart with the fingers.
2. Rinse the eyes for at least 15 minutes. Use an eyewash or running water.
3. Seek medical attention.

## Clean chemicals from the body

1. Remove contaminated clothing.
2. Wash the skin with soap and water for at least 1 minute.
3. If required, seek medical attention.

## Product approval standards

### Regular standards

All electrical ratings and performance of the motors comply with UL, CSA and NEMA standards.

## Product warranty

### Personnel requirements

All work on the product must be carried out by certified electricians and ITT authorized mechanics.

ITT disclaims all responsibility for work done by untrained and unauthorized personnel.

### Modification and spare parts

Modifications or changes to the product/installation should only be carried out after consulting with ITT. Original spare parts and accessories authorized by ITT are essential for compliance. The use of other parts can invalidate any claims for warranty or compensation and explosion-proof approvals.

### Warranty claim

For warranty claim, contact your ITT Fluid Technology representative.

# II. Technical Data

## General

The vortex pump is a ductile/cast iron non-clogging vortex impeller pump, designed to pump a wide variety of solids contaminated liquids.

The pump can be used for sewage and other non aggressive waste water applications.

The impeller leaves a wide unobstructed passage through the volute, in which a strong vortex is created that carries most of the solids.

## Components

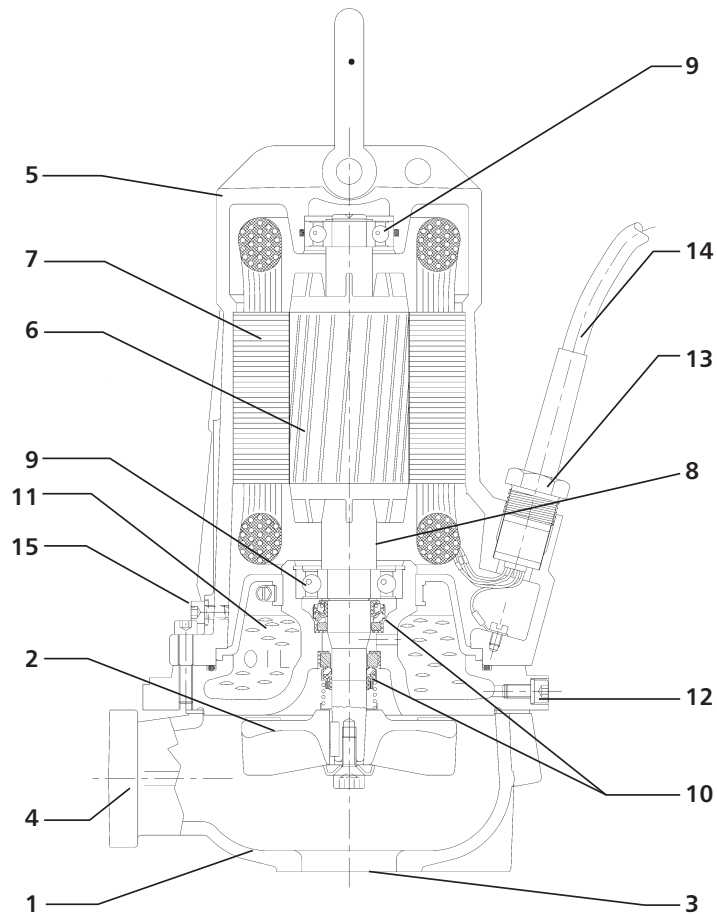

Figure 1

- |                  |                          |                     |
|------------------|--------------------------|---------------------|
| 1. Pump Casing   | 6. Rotor                 | 11. Oil Reservoir   |
| 2. Impeller      | 7. Stator                | 12. Oil Plug        |
| 3. Suction       | 8. Shaft                 | 13. Cable Entry     |
| 4. Discharge     | 9. Bearings              | 14. Cable           |
| 5. Motor Housing | 10. Mechanical seal (2x) | 15. Inspection Plug |

# III. Start Up Procedures

After unpacking the pump, carry out the following check points:

## Delivery Check



Check for possible transport damage and especially check that the cable has not been nicked or damaged.

Check for complete delivery.

When the delivery is incomplete or damaged, please contact your dealer immediately.

## Oil Level

Check the oil level (*see Routine Maintenance section: Oil Level*).

## Power Supply

Before making the electrical connections, check if the line voltage and frequency are the same as on the pump data plate.

For examples of electrical diagrams and pump cable coding, see appendix 1.

## Cable Entry

Especially when the pump has been in storage for a long time, the cable gland should be checked and if necessary tightened.

## Motor Protection

The pump should always be connected to the line by means of a suitable motor protection circuit breaker.

Overload protection must be provided in the panel.

## Motor Check

If in doubt about the condition of the motor or cable, Megger test motor windings against grounding wire.

The phase resistance against grounding wire should be at least 1 Mohm.

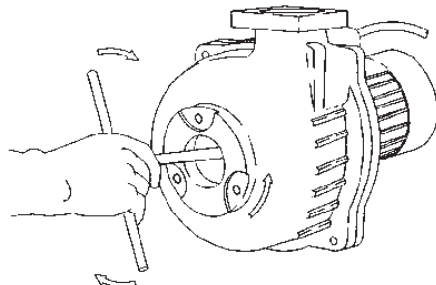

**Figure 2**

Turn the impeller clockwise by hand, using a proper socket wrench (*see figure 6*).

This should be possible without much force.

With this procedure sticking mechanical seal surfaces will be loosened smoothly.

## Installation Parts

Check if all components for your installation are delivered.

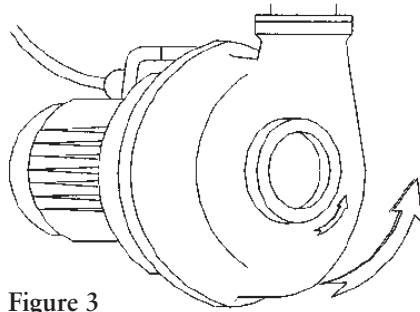

Figure 3

## Direction of Rotation

A correct direction of rotation is essential for proper operation. This can be checked as follows:



- Put the pump in horizontal position and start the pump. Look at impeller through the suction opening, the correct direction of rotation is counterclockwise (see arrow on pump casing, Figure 3). or:
- Starting the pump will give a recoil on the pump frame. Looking at the motor (in vertical position see Figure 4), the recoil is counterclockwise.

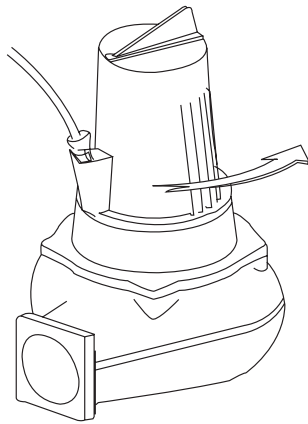

Figure 4

Take care! The recoil can be very powerful!  
Don't go too near rotating parts!

## Current Check

Note the maximum current from the data plate.

Apply an ammeter to one of the phase wires during normal operation. Check that the current is not higher than the value on the data plate. If so check for:

- voltage (too low?)  $\pm 5\%$  nameplate
- specific gravity or viscosity of the fluid (too high?)
- blocked impeller?
- direction of rotation correct?

If the problem cannot be solved contact your dealer.

### Start Frequency

When the pump is controlled by level regulators, the on and off levels should be adjusted in such a way, that the pump does not start more than 20 times an hour.

### Minimum and Maximum Submersion Depth

The motor housing should be at least  $\frac{2}{3}$  submerged for continuous operation at full load (see Hmin.1 Figure 5). It is good practice, whenever possible to keep the motor housing completely under water.

For interrupted level controlled operation, less cooling is required. We recommend not to run the pump with the water level below the top of the volute in order to avoid air being drawn in (see Hmin.2 Figure 5).

Air in the discharge pipes might impair performance.

The maximum submersion depth is 20m/60ft.

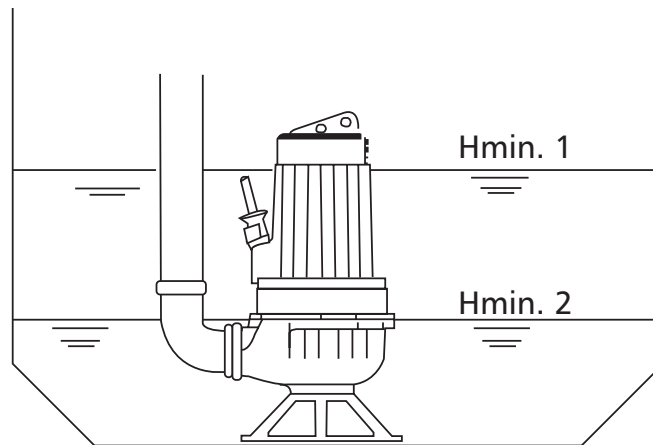

Figure 5

## IV. Installation Options

For the submersible pump the following installations are possible:

- Slide rail installation
- Freestanding wet installation

### Installation - Slide Rail

Stationary wet installation with a slide rail - The pump is automatically coupled to the discharge.

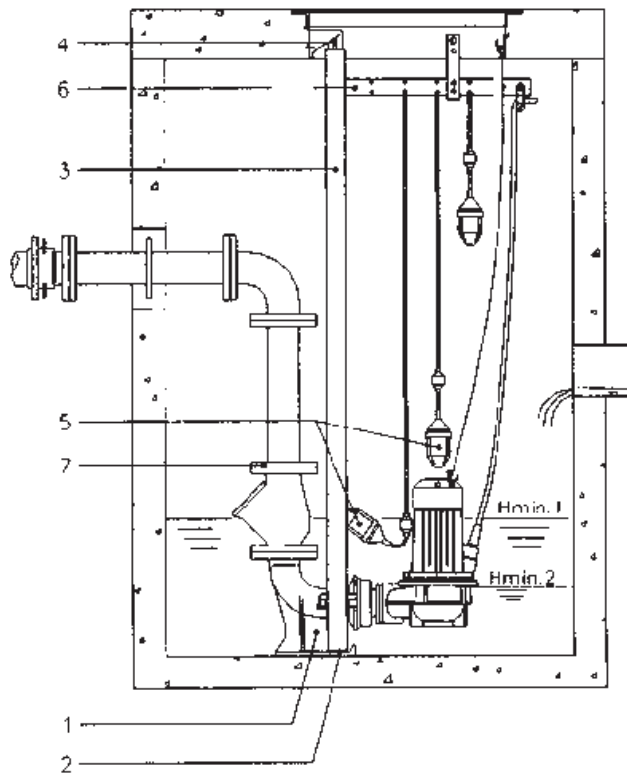

Figure 6

	<b>⚠ WARNING</b>
	<p>Wire rope <b>WILL FAIL</b> if worn-out, overloaded, misused, damaged, improperly maintained or abused. Wire rope failure may cause serious injury or death!</p> <p>Protect yourself and others:</p> <ul style="list-style-type: none"> <li>• ALWAYS INSPECT wire rope for, WEAR, DAMAGE or ABUSE BEFORE USE.</li> <li>• NEVER USE wire rope that is WORN-OUT, DAMAGED or ABUSED.</li> <li>• NEVER OVERLOAD a wire rope.</li> <li>• INFORM YOURSELF: Read and understand manufacturer's literature or "Wire Rope and Wire Rope Sling Safety Bulletin".*</li> <li>• REFER TO APPLICABLE CODES, STANDARDS and REGULATIONS for INSPECTION REQUIREMENTS and REMOVAL CRITERIA.*</li> </ul> <p>* For additional information or the BULLETIN, ask your employer or wire rope supplier.</p> <p>© 1993, Wire Rope Technical Board <span style="float: right;">Form No. 193</span></p>

Except for the pump the following components are necessary:

1. Bottom elbow and pump adapter;
2. Guide bar foundation plate;
3. Two guide bars;

4. Top bracket, mounted within the wellcover clearance;
5. Switches for start-, stop-and alarm signals;
6. Suspension for switches and power supply cables;
7. Piping, non-return valve, discharge bends, etc.

Check points before operating:

- The guide bars must stand vertical (maximum tolerance 3°).
- The installation angle should be: 10-15° (see Figure 7). If necessary, this angle can be changed by alteration of the position of the lifting hook on the suspension bracket on top of the motor (pos. 1). (See bails in accessories.)
- Adjust the start-and stop levels in such a way that the motor does not make more than 20 starts per hour.
- Check that the motor is adequately cooled. The motorhousing should be at least 2/3 submerged for continuous operation at full load (see Hmin.1 Figure 6).

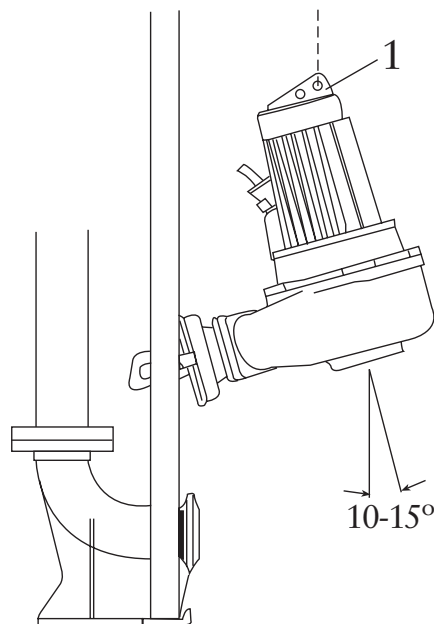

Figure 7

It is good practice, whenever possible, to keep the motor housing completely under water. For interrupted level controlled operation, less cooling is required. We do not recommend running the pump with a water level below the top of the volute, so as to avoid air being drawn in.

Air in the discharge pipes will impair performance.

#### Check Point Installation

In some applications it is possible that the pump will not work due to presence of air in the volute.

Lifting the pump a bit (10-20 mm) while running may solve the problem.

#### Installation - Hard Piped

Hard Piped: semi-permanent fixed wet installation.

Except for the pump the following components are necessary:

1. Pipe, which is fastened to the pump;

2. Pump support, stand, foot;
3. Switches.

Check points before operating:

- Adjust the start-and stoplevels in such a way that the motor does not make more than 20 starts per hour.
- Check that the motor is adequately cooled.

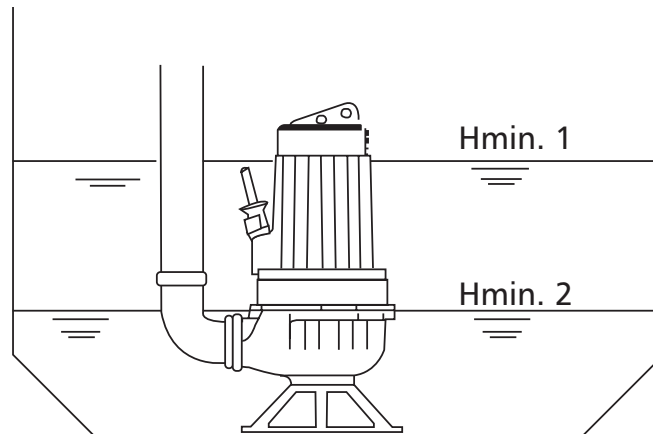

**Figure 8**

The motor housing should be at least 2/3 submerged for continuous operation at full load (see Hmin.1 Figure 8).

**Note:** It is always good practice to drill 1/8" hole in the discharge pipe for venting air. This will prevent the pump from air locking.

# IV. Routine Maintenance

## General



Always disconnect the pump from the mains before inspection or disassembly.  
Clean the pump thoroughly.  
The motor housing can be hot when the pump is just switched off.

## Maintenance Schedule

Check oil once a year. If water is present oil will be milky in color.

## Lubricants

- The bearings are greased for life and need no refill.
- The oil reservoir is filled with SHELL VITREA ISO-VG 46. Viscosity: 46 c St.
- Oil quantities: 20 oz.

## Cable Entry

Especially when the pump has been in use for a long time, the compression of the rubber cable seal might be diminished, which can cause leakage. By screwing in the cable entry the seal will be retained.



Screw in the 2 hexagon socket screws (1).

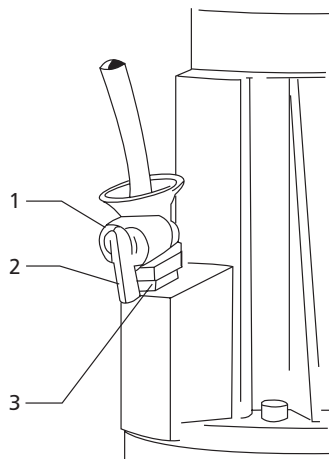

Figure 9

### Oil Level



Put the pump in a horizontal position so that the 2 hexagonal socket screws are on top and one at the bottom (see Figure 11). Unscrew the level plug (1) and the vent plug (2).

The oil level should be at the lower side of the openings (see drawing). By turning the pump a bit this should be visible. If not, fill up to the correct level.

Always use the right kind of oil.

### Oil Change



Collection, storage and removal of the oil should be done according to the regulations of the local authorities.

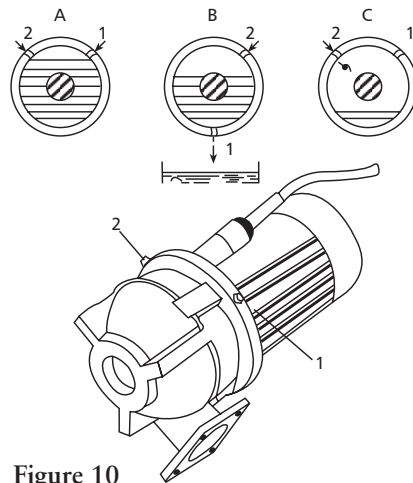

Figure 10



When necessary replace the sealing rings.

Always use the right kind of oil. (See Figure 10).

Put the pump in a horizontal position so that one of the oil plugs is at the bottom. Remove the vent plug (2). Put a receiving bin underneath the drain plug (1). Remove the plug and drain the oil.

Rotate the pump so that the 2 openings are on top.

Refill the oil housing. The oil level should be at the lower side of the openings. Replace the plugs.

### Motor Housing

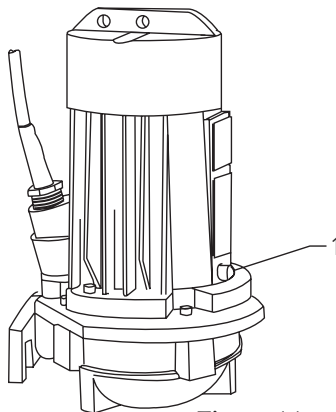

Figure 11



Unscrew the inspection plug of the motor housing. Put the pump in horizontal position with the inspection opening downwards. If water is present it will run out this way. A small amount of water, due to condensation is permissible. More water is an indication of leakage of the seal or housing. Oil is an indication of seal failure between motorhousing and oil chamber. Motor chamber is air filled only.

# V. Transportation and Storage



The pump can be transported and stored in both horizontal and vertical position.

Never lift the pump by the motor cable. Always use the lifting shackle.

In case of long storage, the pump must be protected against moisture and heat.

	<p><b>WARNING</b></p> <p>Wire rope WILL FAIL if worn-out, overloaded, misused, damaged, improperly maintained or abused. Wire rope failure may cause serious injury or death!</p> <p>Protect yourself and others:</p> <ul style="list-style-type: none"> <li>• ALWAYS INSPECT wire rope for WEAR, DAMAGE or ABUSE BEFORE USE.</li> <li>• NEVER USE wire rope that is WORN-OUT, DAMAGED or ABUSED.</li> <li>• NEVER OVERLOAD a wire rope.</li> <li>• INFORM YOURSELF: Read and understand manufacturer's literature or "Wire Rope and Wire Rope Sling Safety Bulletin".*</li> <li>• REFER TO APPLICABLE CODES, STANDARDS and REGULATIONS for INSPECTION REQUIREMENTS and REMOVAL CRITERIA.*</li> </ul> <p>* For additional information or the BULLETIN, ask your employer or wire rope supplier.</p> <p><small>© 1993, Wire Rope Technical Board Form No. 193</small></p>
--	--

Before storing the pump, clean it with a water jet and check the motor housing for water ingress (see *Motor Housing under Routine Maintenance section*). Every three months, turn the impeller by hand. This is necessary to prevent sticking of the mechanical seal surfaces (see Figure 12).

After 6 months of storage, a general inspection is advised, before installing the pump. Follow the instructions of *Section III: Start Up Procedures*.

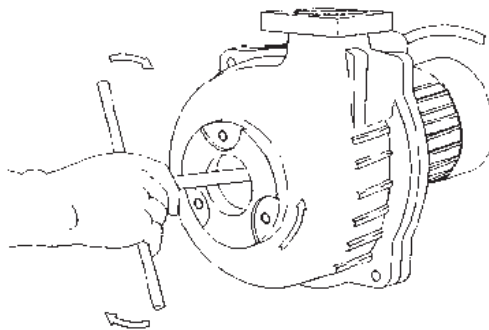

Figure 12

# VI. Seal Fail and High Temperature

## Seal Fail

As a safeguard against water ingress into the motor, the pump is equipped with a water detector.

The water detector detects water which might have entered the oil housing or motor housing due to seal failure or cable damage.

The water detector, when connected to a seal fail circuit, alarms of water intrusion.

The probe itself is a non-active electrode, placed in oil and motor housing. It is used in conjunction with a relay in the control circuit that measures the resistance between probe and frame.

If only air or oil is present, the resistance is over 33,000 Ohm. If water enters, the resistance will decrease to as low as 300 to 500 Ohm. We advise to use CentriPro seal fail relay. This relay switches at 33,000 Ohms. See panel options in CentriPro catalog.

## High Temperature



The pump is equipped with high temperature. The normal resistance of the high temperature thermoswitch is 0-5 ohms. Leads on the cable (4 and 5 (*see page 11*)) should read "closed contact". Contacts will give open reading in high temperature situation (125° – 140° C). High temperature will close once motor temperature is normal (95° – 110° C).

# VII. Trouble Shooting

## Safety

When working on the motor, make sure that the power is switched off. When working on the pump make sure it cannot start unexpectedly. Only qualified electricians may do the electrical work. When starting the pump ensure nobody goes near rotating parts.

PROBLEM	POSSIBLE CAUSE	REQUIRED ACTION	CHECK POINTS
Pump does not start	No voltage on motor terminals	Check power supply	*No power *Main isolator switch *Fuses
		Check motor protection	*Earth leakage relay *Motor protection relay *Motor temperature *Water detector
		Check start and stop signals	*Too low water level *Obstructed level switches *Switches interchanged *Control panel
	Motor failure	Check motor wiring	*Continuity and isolation *Phase resistance
Pump does not stop	No stop signal	Check level regulation	*Float switches *Control panel
	Wrong start and stop level	Check level regulation	*Obstructed level switches *Adjust start and stop level *Power supply not stable
Pump starts and stops repeatedly	Fault in power supply	Check power supply	*Low voltage *Not all 3 phases available *Setting of motor protection
	Motor overloaded	Check pump	*Wrong direction of rotation *Impeller blocked *Protection in automatic reset mode
	Motor overheated	Check cooling Check motor	*Continuity and isolation *Fuses
Current too high	Fault in power supply	Check power supply	*Low voltage *Impeller blocked
	Pump failure	Check pump	*Visc. or spec. gravity too high *Wrong direction of rotation
Pump runs but no flow or too low flow	Clogging or air lock	Check discharge and coupling	*Discharge obstructed *Valve fully or partly closed *Air pocket in pump or discharge *Coupling leaks
	Pump failure	Check pump	*Impeller or volute blocked *Pump is sucking too much air *Worn or broken impeller
	Fault in power supply	Check power supply	*Control panel *Fuses *Low voltage

PROBLEM	POSSIBLE CAUSE	REQUIRED ACTION	CHECK POINTS
Pump runs but no flow or too low flow ( <i>cont.</i> )	Too low capacity	Check discharge	*Discharge obstructed *Valve fully or partly closed *Air pocket
High level alarm	Pump failure	Check pump	*Impeller or volute blocked *Pump is sucking to much air *Worn or broken impeller *Worn or broken bearings
	Fault in power supply	Check power supply	*Fuses *Control panel
	Motor failure	Check motor	*Continuity and isolation

# VIII. Appendix 1: Cable Connections

## PUMP CABLE CONNECTIONS

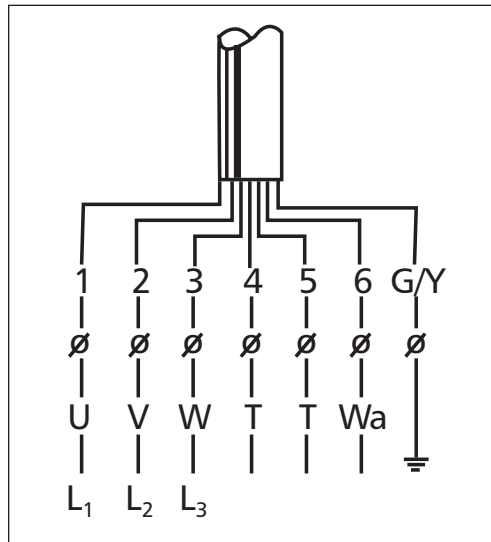

1 —	Black	----->	Motor
2 —	White	----->	Motor
3 —	Red	----->	Motor (1Ø capacitors)
4 —	Orange	----->	High Temperature
5 —	Blue	----->	High Temperature
6 —	Yellow	----->	Seal Fail
7 —	Green/Yellow	----->	Ground

# Notes

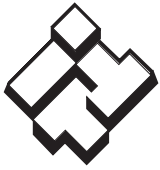

# ITT

## Wastewater

### LIMITED WARRANTY

This warranty applies to all water systems pumps manufactured by ITT Corporation.

Any part or parts found to be defective within the warranty period shall be replaced at no charge to the dealer during the warranty period. The warranty period shall exist for a period of twelve (12) months from date of installation or eighteen (18) months from date of manufacture, whichever period is shorter.

A dealer who believes that a warranty claim exists must contact the authorized ITT Corporation distributor from whom the pump was purchased and furnish complete details regarding the claim. The distributor is authorized to adjust any warranty claims utilizing the ITT Corporation Customer Service Department.

**The warranty excludes:**

- (a) Labor, transportation and related costs incurred by the dealer;
- (b) Reinstallation costs of repaired equipment;
- (c) Reinstallation costs of replacement equipment;
- (d) Consequential damages of any kind; and,
- (e) Reimbursement for loss caused by interruption of service.

**For purposes of this warranty, the following terms have these definitions:**

- (1) "Distributor" means any individual, partnership, corporation, association, or other legal relationship that stands between ITT Corporation and the dealer in purchases, consignments or contracts for sale of the subject pumps.
- (2) "Dealer" means any individual, partnership, corporation, association, or other legal relationship which engages in the business of selling or leasing pumps to customers.
- (3) "Customer" means any entity who buys or leases the subject pumps from a dealer. The "customer" may mean an individual, partnership, corporation, limited liability company, association or other legal entity which may engage in any type of business.

**THIS WARRANTY EXTENDS TO THE DEALER ONLY.**

The ITT Engineered Blocks Symbol are registered trademarks and tradenames of ITT Corporation.

SPECIFICATIONS ARE SUBJECT TO CHANGE WITHOUT NOTICE.

**IM205 Revision Number 1 March, 2009**

Copyright (c) 2009 ITT Corporation

*Engineered for life*