

ITT

BAU

Commercial Water

Goulds Pumps

2AUW, 3AUW

Gasoline Engine Self-Priming Centrifugal
Portable Contractor Pumps

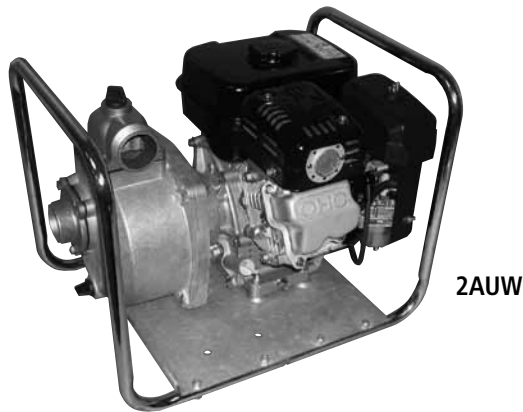

FEATURES

- Reliable Subaru Robin engines:
 - Overhead cam design
 - Low oil shutdown
 - Automatic decompression system
- Lightweight, portable and compact design.
- Die cast aluminum casing, engine housing and volute.
- Durable cast iron impeller.
- Trouble-free mechanical seal, carbon/ceramic/BUNA-N.
- Rugged, convenient carry handle/base.
- Multi-position discharge connection.
- Injection molded suction strainers.
- Fittings to accommodate NPT connections.
- Available in 2 sizes:
 - 2" connections, 4.5 HP
 - 3" connections, 6.0 HP.

 **GOULDS PUMPS**

Goulds Pumps is a brand of ITT Corporation.

www.goulds.com

Engineered for life

APPLICATIONS

Home, farm and cottage water systems and booster service.

PUMP SPECIFICATIONS

2AUW (2" Connections):

- Length: 20.50"
- Width: 15.00"
- Height: 15.75"
- Weight: 45 lbs.
- Solids: 1/2" Dia.

3AUW (3" Connections):

- Length: 20.75"
- Width: 15.50"
- Height: 17.25"
- Weight: 52 lbs.
- Solids: 1/2" Dia.

ENGINE SPECIFICATIONS

2AUW (2" Connections):

- Horsepower: 4.5 HP
- Displacement: 126 cc
- Fuel capacity: .7 gal.
- Oil capacity: 20 oz.
- Air cleaner: Paper
- Ignition: Electronic
- Run time: 2.7 hours

3AUW (3" Connections):

- Horsepower: 6.0 HP
- Displacement: 169 cc
- Fuel capacity: .95 gal.
- Oil capacity: 20 oz.
- Air cleaner: Paper
- Ignition: Electronic
- Run time: 2.5 hours

2AUW PERFORMANCE

Flow (GPM)	0	25	50	75	100	125	145
TDH (Ft.)	105	96	80	60	40	20	0

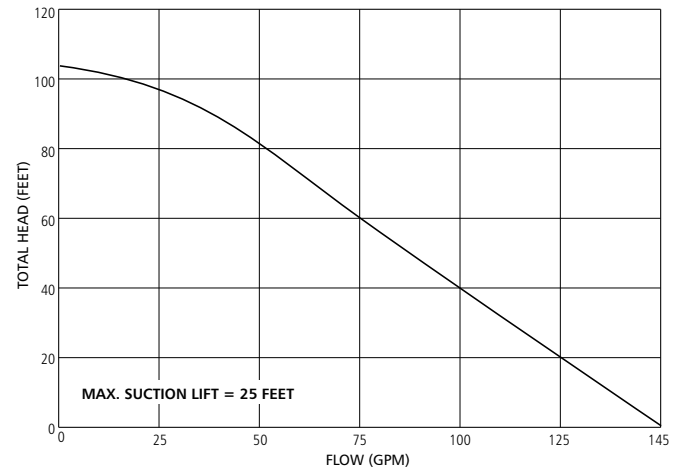

3AUW PERFORMANCE

Flow (GPM)	0	40	80	120	160	170
TDH (Ft.)	100	78	57	35	14	0

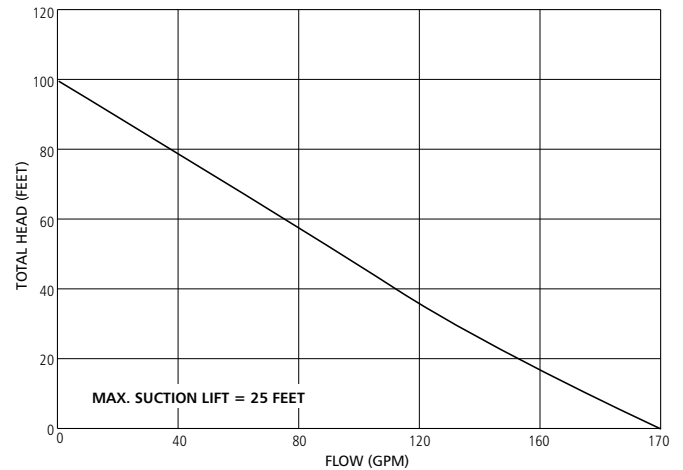

DIMENSIONS AND WEIGHTS

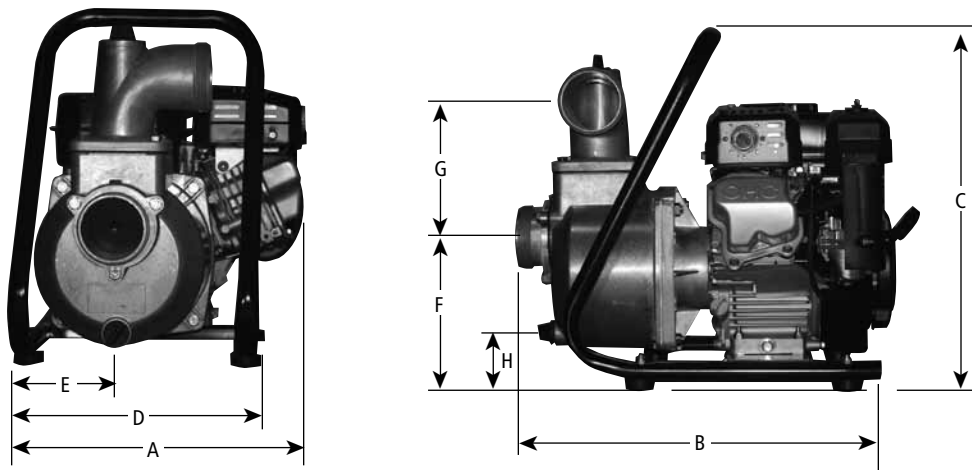

Model	Dimension (in inches)								Weight (lbs.)
	A	B	C	D	E	F	G	H	
2AU	15	18 ³ / ₄	15 ³ / ₈	14 ³ / ₈	5	7 ¹ / ₄	5 ¹ / ₄	2 ¹ / ₂	59
3AU	15	20 ³ / ₄	18 ¹ / ₂	12 ³ / ₄	6	7 ³ / ₄	7 ¹ / ₄	2 ¹ / ₂	63

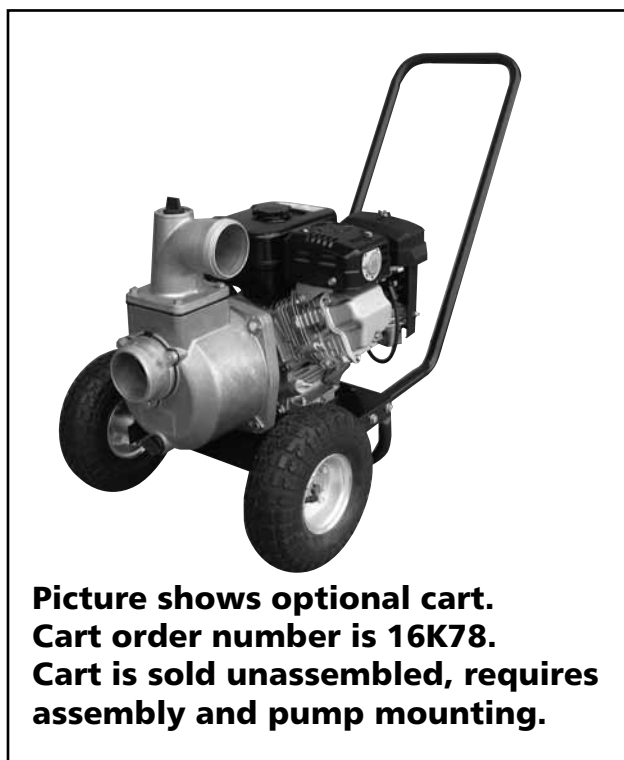



ITT

COMPONENTS LIST

Item No.	Part Description	Item No.	Part Description
1	Engine – 4½ HP	9	Suction strainer
	Engine – 6 HP	10	Pump housing
2	Locknut – ¾" – 16	11	Bolt – ¾" – 16" x 1½"
3	Engine adapter	12	O-ring, drain/filler plug
4	Aluminum washer – ½"	13	Drain/fill plug
5	Bolt – ½" – 24" x ¾"	14	Flapper valve
6	Seal assembly	15	Suction flange BSP*
	Shaft sleeve		Suction flange NPT
	O-ring housing	16	Bolt – ½" – 18" x ¾"
	O-ring volute	17	Discharge elbow BSP*
7	Impeller		Discharge elbow NPT
	Volute	18	Discharge gasket
	Imp. shim: 010, 020, 030	19	Bolt – ½" – 18" x 1½"
8*	Hose mounting gasket	20	Lock nut – ½" – 18
	Hose mounting nipple	21	Cradle assembly
	Hose mounting nut		
	Suction strainer		

*Supplied with 2AU, built before September 2005.
BSP fittings no longer available.

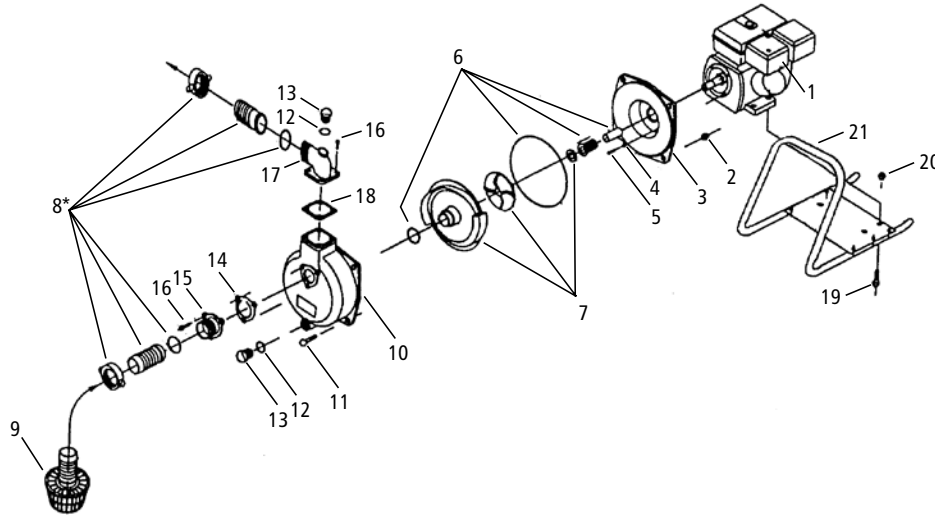

ITT

2881 East Bayard Street, Seneca Falls, NY 13148

Phone: (315) 568-7123 • Fax: (315) 568-7973

www.goulds.com

Goulds Pumps is a registered trademark of ITT Corporation. ITT, the Engineered Blocks Symbol and Engineered for Life are registered trademarks of ITT Manufacturing Enterprises, Inc.

Copyright © 2010 ITT Corporation BAU January, 2010 Printed in U.S.A.
SPECIFICATIONS ARE SUBJECT TO CHANGE WITHOUT NOTICE.