

# HYDROMATIC®

ENGINEERED PRODUCTS

## HPD200 – 60 Hz

## HPDY200 – 50 Hz

**Submersible  
Positive Displacement  
Grinder Pump**

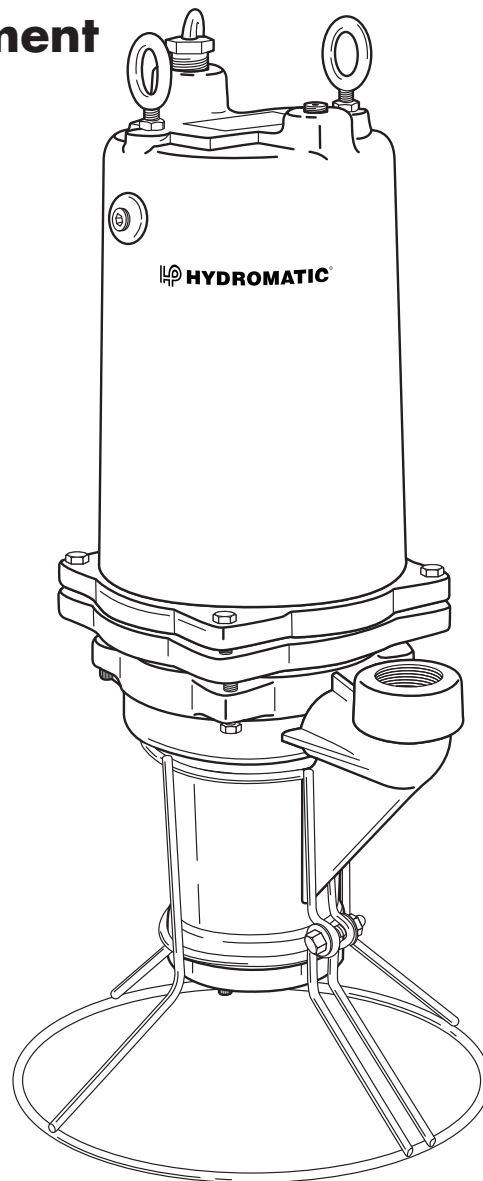

NOTE! To the installer: Please make sure you provide this manual to the owner of the pumping equipment or to the responsible party who maintains the system.



## General Information

Thank you for purchasing your Hydromatic® pump. To help ensure years of trouble-free operation, please read the following manual carefully.

**WARNING: Only qualified personnel shall install or service this pump.**

### Before Operation:

Read the following instructions carefully. Reasonable care and safe methods should be practiced. Check local codes and requirements before installation.

### Attention:

This manual contains important information for the safe use of this product. Read this manual completely before using this product and refer to it often for continued safe product use. **DO NOT THROW AWAY OR LOSE THIS MANUAL.** Keep it in a safe place so that you may refer to it often.

### Unpacking Pump:

Remove pump from carton. When unpacking unit, check for concealed damage. Claims for damage must be made at the receiving end through the delivery carrier. Damage cannot be processed from the factory.

**WARNING: Before handling these pumps and controls, always disconnect the power first. Do not smoke or use sparkable electrical devices or flames in a septic (gaseous) or possible septic sump.**

**WARNING: Read all the instructions before starting any operation on pump.**

Always disconnect the pump and controls from its power source before handling or making any adjustments.

**WARNING: Risk of Electrical Shock—This pump has not been investigated for use in swimming pool areas.**

**WARNING: Risk of Electrical Shock—This pump is supplied with a grounding conductor and grounding-type attachment plug. To reduce risk of electrical shock, be certain that it is connected only to a properly grounded, grounding-type receptacle.**

1. Connect only to a properly grounded, grounding type receptacle or control panel.
2. Septic tank is to be vented in accordance with local plumbing codes.
3. Do not smoke or use sparkable electrical devices or flame in a septic (gaseous) or possible septic sump.
4. A septic sump condition may exist and if entry into sump is necessary, then (1) provide proper safety precautions per OSHA requirements and (2) do not enter sump until these precautions are strictly adhered to.
5. Do not install pump in location classified as hazardous per N.E.C., ANSI/NFPA 70 - 1999.

**Failure to heed the above cautions could result in injury or death.**

## Pump Cautions and Warnings

1. **CAUTION** – To reduce risk of electrical shock, pull plug before servicing this pump.
2. **WARNING** – Risk of electrical shock – this pump has not been investigated for use in swimming pool areas.
3. **WARNING** – See installation and service manual for proper installation.
4. **WARNING** – To reduce risk of electrical shock, pump is provided with grounding wire. Be certain that it is connected to ground.
5. **WARNING** – Hazardous moving parts. To reduce the risk of injury, disconnect power before servicing pump.
6. **CAUTION** – To reduce the risk of electric shock, **DO NOT** remove cord or strain relief. **DO NOT** connect conduit to pump. Electrical installations shall be in accordance with the National Electrical Code and all applicable local codes and ordinances.
7. For use with maximum 140°F water.
8. Tank should be vented in accordance with local plumbing codes and should not be installed in locations classified as hazardous, in accordance with the National Electrical Code, ANSI/NFPA 70-1999.
9. **CAUTION** – Risk of electric shock. Do not remove cord and strain relief. Do not connect conduit to pump.
10. **WARNING** – Severe injury may result from accidental contact with moving cutters. Keep clothing, hands and feet away from cutters any time power is connected to the pump.

11. **CAUTION** – Never work on pump with power on. Make sure that the ground wire is securely connected and that the unit is properly grounded in accordance with local codes.

## Pump Installation

### Pump Description:

The Hydromatic pumps covered by these instructions are submersible grinder pumps.

The cutter blades are on the suction side of the positive displacement pump impeller and discharge directly into the inlet of the impeller. The integral stainless steel pump motor shaft is sealed by a single mechanical seal.

Two ball bearings are used to handle the loads in this design. The upper bearing takes radial loads, while the larger lower bearing handles both thrust and radial loads. Both bearings are permanently lubricated by the dielectric oil in the motor housing. The motor is fixed within the motor housing and is completely submerged in the dielectric oil for maximum heat transfer. The motor housing and seal chamber are completely sealed with O-rings located at mating part faces. The power cord entry system is designed to give reliable sealing.

The first seal is made by compression of a rubber gasket by the cord grip, thereby expanding to fill the cord entry of the motor housing. The cord grip forms a second seal around the molded cord end and provides strain relief.

### Application:

These pumps are designed for either residential or industrial sewage discharge applications with

a pH ranging from 5 to 9, specific gravities from 0.9 to 1.1, viscosities ranging from 28 to 35 S.S.U., and temperatures up to 140°F.

### Receiving Pump:

Inspect pumps on arrival for possible concealed damage in shipping. Any damage should be reported immediately to delivering carrier. Claims for damage must originate at the receiving end. Claims for shipping damage cannot be processed at the factory.

### Codes:

All local wiring codes must be observed. Consult the local inspector before installation to avoid costly delays that can occur due to rejection after job is finished.

### Pump Not Operating or in Storage:

Pumps with carbon ceramic seals must have manually rotated (6 revolutions) after setting non-operational for 3 months or longer and prior to electrical start-up.

### Installing Pump in Sump:

Before installing pump in sump, lay it on its side and rotate grinder shaft. Stator boot and rotor may be slightly stuck due to factory test water, so it must be broken loose by rotating shaft with a screwdriver at grinder end. The common shaft should turn with a slight resistance. Slight lubrication by means of a small amount of lubricating oil down the cavity inlet of the stator boot and rotating shaft to pre-lube stator boot and rotor before start is recommended. Do not connect the power until after this test.

Clean all trash and sticks from sump and connect pump to piping. A check valve must be installed on each pump.

### Location:

If pumps are installed in an existing basin or concrete sump, the piping can either be connected permanently or rails and brackets can be furnished for mounting to walls of basin. In either case, be sure that the Hydromatic non-clog check valve is used and that the pumps are submerged in a vertical position. The complete factory built packaged system is recommended for the most satisfactory installation and generally for the lowest cost where expensive installation labor is involved.

### Making Electrical Connections:

All electrical wiring must be in accordance with local code, and only qualified electricians should make the installations. Complete wiring diagrams are included for use in making the installation. All wires should be checked for shorts to ground with an ohmmeter or Megger after the connections are made. This is important, as one grounded wire can cause considerable trouble.

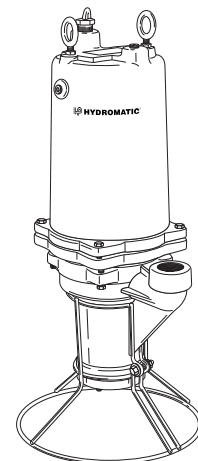

# Pump Operations

## Starting the Pump:

**WARNING: Severe injury may result from accidental contact with moving cutter. Keep clothing, hands and feet away from cutter any time power is connected to the pump.**

To start the pump, perform the following steps in order:

1. Grinder pump is single phase; no rotation check is necessary.
2. Run water into sump until motor is covered.
3. Open gate valve in discharge line.
4. Turn pump on. If pump runs and sump liquid does not pump down, stop pump and close discharge gate valve. Then lift pump until sealing flange is open to vent off trapped air. Lower pump, open discharge valve, and start the pump again.

### CAUTION:

**Positive displacement pump is designed to operate at minimum 5 GPM capacity. Running pump at shut-off condition or with gate valve closed can result in damage to the pumping stator boot and rotor.**

5. Level control should be set so that pump turns off when level is about 2 inches above inlet of pump suction and turns on when level is about 2 inches above motor.

6. If problems occur, check power source. Make sure a separate supply line is available. Verify voltage supply.
7. Check resistance of windings. (See Chart) If not within guidelines, return pump to authorized Hydromatic service or repair center.

As the motors are oil filled, no lubrication or other maintenance is required. Pump should be checked every quarter for corrosion and wear.

# Pump Maintenance

**CAUTION: Never work on pump with power on. Make sure that the ground wire is securely connected and that the unit is properly grounded in accordance with local codes.**

**CAUTION: Severe injury may result from accidental contact with moving cutter. Keep clothing, hands and feet away from cutter any time power is connected to the pump.**

## Replacing Cutter Parts:

If necessary to replace grinder parts because of wear or to inspect for clogging:

1. Close gate valve at pump discharge.
2. Turn off circuit breaker.

**CAUTION: Never work on pump with the power on. Be sure ground wire from pump is connected to a good ground such as a water pipe.**

3. Remove pump from sump.
4. Unscrew screws (5) and remove stationary cutter ring assembly (4). Radial cutter (3) can be screwed off the common shaft by lightly tapping cutter and unscrewing it counterclockwise while holding end of common shaft with a screwdriver in slot at cutter end of shaft.
5. Radial cutter (3) and stationary cutter (4) can now be inspected for wear and be replaced if necessary.

## Stator Boot and Rotor Inspection and/or Replacement:

If necessary to inspect or replace the stator boot and rotor, the following procedure should be followed:

1. Unscrew socket head screws (12) and remove volute case (1). Note: Turning common shaft clockwise while removing volute case can ease removal.
2. Radial cutter (3) and stationary cutter (4) can be inspected for wear and replaced if necessary.
3. Stator boot and rotor are now exposed to check for any obstructions in or wear of stator boot.
4. If necessary to replace stator boot (21), remove screws (9) and retainer ring (8) from volute (1). Stator boot (21) can now be lifted out from the volute recess. To replace pump rotor (22), use a suitable size center punch and remove lower roll pin (6) from common shaft. Pump rotor (22) can now slide off common shaft.

5. Clean all parts thoroughly before proceeding with reassembly. Slide new rotor (22) on common shaft and carefully replace lower roll pin (6). Place stator boot (21) back in volute recess, replace retainer ring (8) and tighten screws (9). Place volute (1) carefully back over rotor (22) and reattach to seal/bearing housing (2) with socket head screws (12).
6. Replace radial cutter (3) on common shaft. Lightly tap radial cutter (3) clockwise to ensure full engagement onto common shaft.
7. Replace stationary cutter assembly (4) and screw it down with screws (5). Carefully rotate shaft by using screwdriver in slot on shaft, to ensure free rotation of pump.
8. Plug pump into power source and operate for a few seconds only (refer to caution note below) to ensure parts are not rubbing under electrical operation.
9. Replace stationary cutter assembly (4), and screw down with screws (5).
10. Plug pump into power and operate for a few seconds only to ensure parts are not rubbing.

**CAUTION: Do not run dry longer than 10 seconds maximum, otherwise damage to stator boot can occur.**

#### **Replacing Seal:**

1. Drain the oil from the pump by removing the fill plug (10) located on the side of the motor housing (18).
2. Remove the volute and cutters per the instructions listed under “Stator Boot and Rotor Inspection and/or Replacement”

and “Replacing Cutter Parts” sections of this manual.

3. Remove the pump rotor per instructions listed under replacing grinder parts section in this manual.
4. Remove the seal (17) rotating elements by sliding the spring bellows off the common shaft, then using two screwdrivers, slide the carbon seal assembly off by prying on the retaining ring.
5. Using a screwdriver, break the old stationary portion of the seal (17) to allow for removal.
6. Take the stationary portion of the new seal (17), and lube the rubber material with good quality dielectric oil. Press the stationary portion of the new seal into the seal/bearing housing (2).

**CAUTION: Do not reuse old seal parts. Replace all parts with new. Mixing old and new parts could cause immediate seal failure.**

7. Using a good quality dielectric oil, lube the rubber material on the carbon seal assembly (17) and press it on the common shaft.
8. Using a pressure gauge with a fill stem, pressurize the motor housing no more than 7 psig with dried air and check for leaks. If after several minutes the gauge reads the same, the seal is good and you can continue with assembly.

**Note: It is normal to observe some air bubbles in the seal area initially as the seal seats. If bubbles do not stop within a few seconds, the seal is either not properly installed or is damaged.**

9. Reassemble the pump rotor, cutter and volute as outlined in the replacing cutter parts section of this manual.
10. Refill motor housing with a good quality dielectric oil. Fill the motor housing so that the tops of the motor windings have been covered, but leave an air gap to allow for expansion of the oil.

**Note: When applying power, be sure the pump is restrained from turning by holding the pump at the motor housing, or by clamping it in a holding fixture.**

**WARNING: Severe injury may result from accidental contact with moving cutter. Keep clothing, hands and feet away from cutter any time power is connected to the pump.**

**Below is a list of troubles and their probable causes:**

#### **No liquid delivered**

1. Pump airbound
2. Discharge head too high
3. Pump or piping plugged
4. Speed too low

#### **Insufficient liquid delivered**

1. Discharge head too high
2. Cutter partially plugged or damaged
3. Stator boot or rotor damaged or worn
4. Speed too low

#### **Insufficient discharge pressure**

1. Air or gases in liquid
2. Stator boot or rotor damaged or worn
3. Speed too low

# Pump Maintenance

## Pump overloads motor

1. Specific gravity or viscosity of liquid too high
2. Speed too high

3. Head lower than rating, pumping too much liquid
4. Pump clogged
5. Defective bearings

## Pump is noisy

1. Defective bearings
2. No diametral clearance

between radial cutter and cutter ring

**If the cause of the trouble cannot be determined and corrected as outlined above, contact your nearest factory representative.**

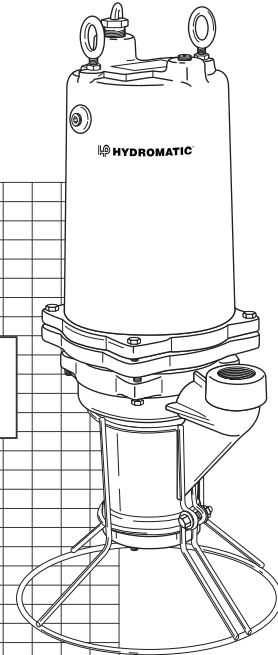
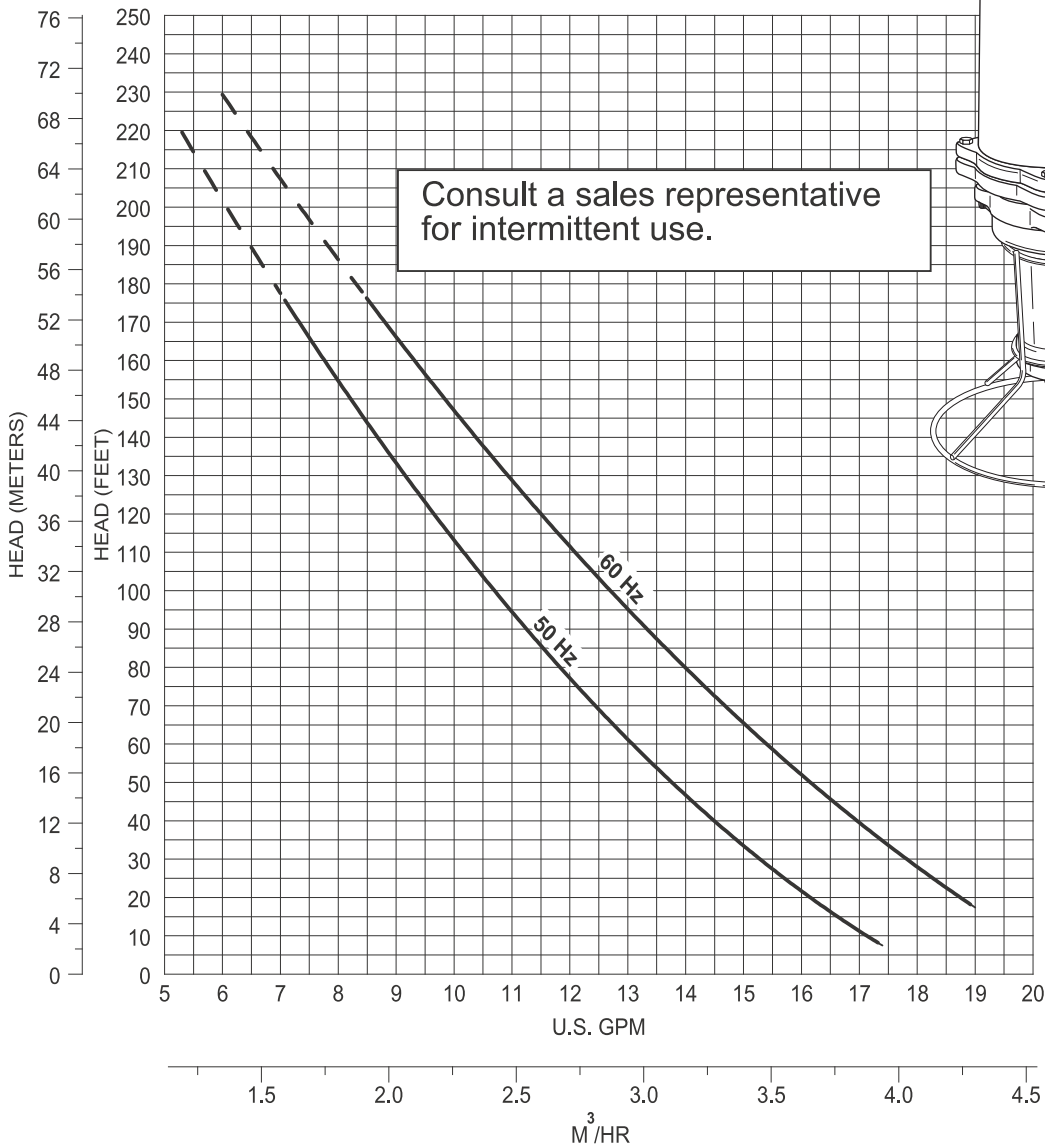

**HPD200  
PERFORMANCE CURVE**

# HPD200/ HPDY200

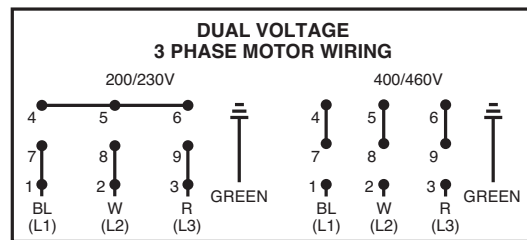
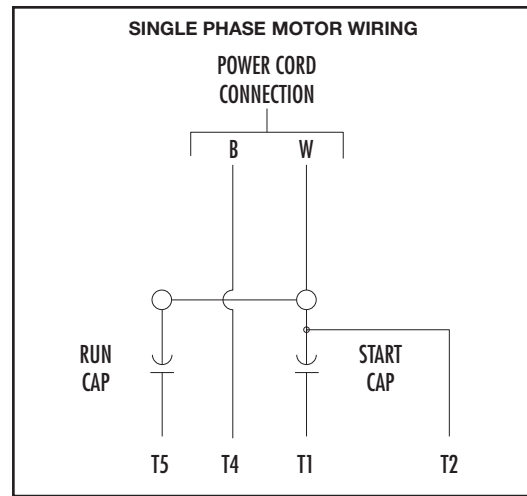
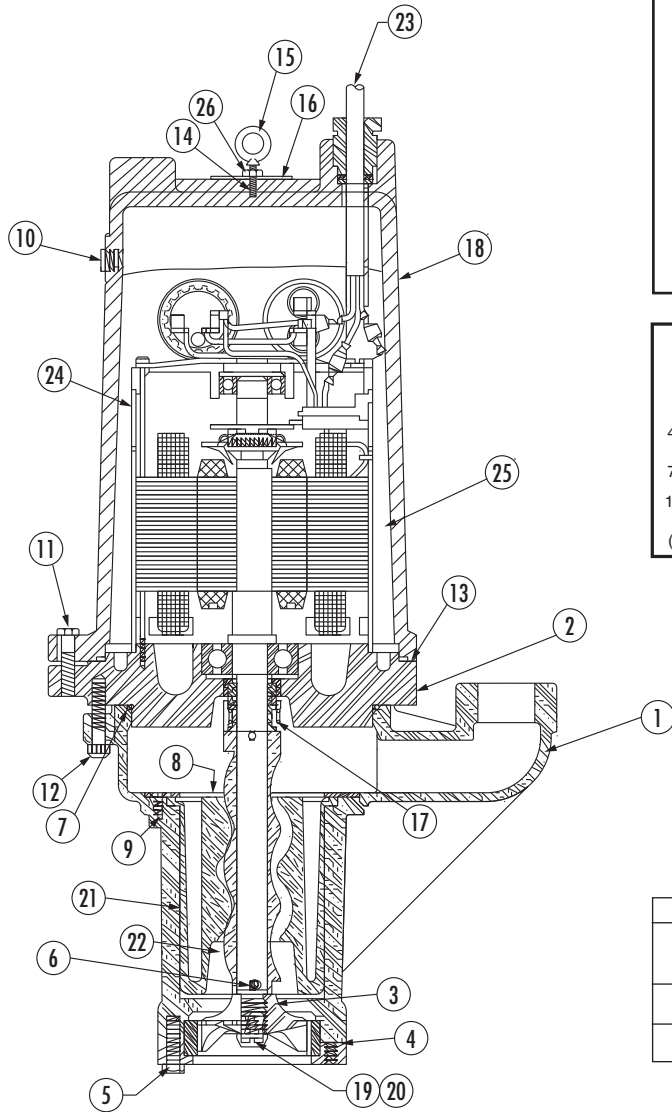

## WINDING RESISTANCE CHART

		1ø 230V	3ø 400V
	Start Winding	Run Winding	Run Winding
HPD200	3.15	3.05	N/A
HPDY200	4.67	2.37	3.66

**ORDERING REPLACEMENT PARTS:** Product improvements are made from time to time. The latest part design will be furnished as long as it is interchangeable with the old part. When ordering replacement parts, always furnish the following information: (1) pump serial number, (2) pump model and size, (3) part description, (4) part number, (5) impeller diameter (if ordering impeller), (6) quantity required, and (7) shipping instructions.

Ref. No.	Part No.	Part Description	Qty.
1	14624-000-2	Case – Volute	1
2	14569-001-2	Housing – Seal/Bearing	1
3	215828000K	Cutter – Radial	1
4	215848000K	Cutter – Stationary, Assy	1
5	19099A012	Screw – Cap	3
6	00180-002-1	Pin – Roll, Lower	1
7	00834-023-1	O-Ring	1
8	14627-000-1	Ring – Retainer	1
9	00829-007-1	Screw – Ring Retainer	3
10	14981-001-1	Pipe Plug	2

Ref. No.	Part No.	Part Description	Qty.
11	19100A012	Screw – Cap	4
12	00178-006-1	Screw – Socket	4
13	00077-011-1	O-Ring	1
14	04580-001-1	Screw – Drive	2
15	00589-002-1	Bolt – Eye	2
16	14596-000-1	Nameplate	1
17	14573-000-1	Seal – Shaft	1
18	14589-002-1	Housing – Motor	1
19	14885-000-1	Screw – Shaft, Motor	1
20	05570-005-1	Washer – Shaft	1

Ref. No.	Part No.	Part Description	Qty.
21	14761-000-1	Stator – Pump	1
22	14762-101-1	Rotor – Helix	1
23	25338B001	Power Cord, 1ø, 60 Hz	1
	14588-530-1	Power Cord, 1ø, 50 Hz	1
	14588-540-1	Power Cord, 3ø, 50 Hz	1
24	14570-100-1	Motor (1ø, 60 Hz – HPD200)	1
	14570-101-1	Motor (1ø, 50 Hz – HPDY200)	1
	14570-201-1	Motor (3ø, 50 Hz – HPDY200)	1
25	24709110000	Paraffinic Oil	0.90
26	01032-002-1	Hex Nut	2







# STANDARD LIMITED WARRANTY

**HYDROMATIC®** warrants its products against defects in material and workmanship for a period of 12 months from the date of shipment from Hydromatic or 18 months from the manufacturing date, whichever occurs first - provided that such products are used in compliance with the requirements of the Hydromatic catalog and technical manuals for use in pumping raw sewage, municipal wastewater or similar, abrasive free non-corrosive liquids.

During the warranty period and subject to the conditions set forth, Hydromatic, at its discretion, will repair or replace to the original user, the parts which prove defective in materials and workmanship. Hydromatic reserves the right to change or improve its products or any portions thereof without being obligated to provide such a change or improvement for prior sold and/or shipped units.

**Start-up reports and electrical schematics** may be required to support warranty claims. Warranty is effective only if Hydromatic authorized control panels are used. All seal fail and heat sensing devices must be hooked up, functional and monitored or this warranty will be void. Hydromatic will only cover the lower seal and labor thereof for all dual seal pumps. Under no circumstance will Hydromatic be responsible for the cost of field labor, travel expenses, rented equipment, removal/reinstallation costs or freight expenses to and from the factory or an authorized Hydromatic service facility.

**This limited warranty will not apply:** (a) to defects or malfunctions resulting from failure to properly install, operate or maintain the unit in accordance with the printed instructions provided; (b) to failures resulting from abuse, accident or negligence; (c) to normal maintenance services and parts used in connection with such service; (d) to units which are not installed in accordance with applicable local codes, ordinances and good trade practices; (e) if the unit is moved from its original installation location; (f) if unit is used for purposes other than for what it is designed and manufactured; (g) to any unit which has been repaired or altered by anyone other than Hydromatic or an authorized Hydromatic service provider; (h) to any unit which has been repaired using non factory specified/OEM parts.

**Warranty Exclusions:** HYDROMATIC MAKES NO EXPRESS OR IMPLIED WARRANTIES WHICH EXTEND BEYOND THE DESCRIPTION ON THE FACE HEREOF. HYDROMATIC SPECIFICALLY DISCLAIMS THE IMPLIED WARRANTIES OF MERCHANTABILITY AND FITNESS FOR ANY PARTICULAR PURPOSE.

**Liability Limitation:** IN NO EVENT SHALL HYDROMATIC BE LIABLE OR RESPONSIBLE FOR CONSEQUENTIAL, INCIDENTAL OR SPECIAL DAMAGES RESULTING FROM OR RELATED IN ANY MANNER TO ANY HYDROMATIC PRODUCT OR PARTS THEREOF. PERSONAL INJURY AND/OR PROPERTY DAMAGE MAY RESULT FROM IMPROPER INSTALLATION. HYDROMATIC DISCLAIMS ALL LIABILITY, INCLUDING LIABILITY UNDER THIS WARRANTY, FOR IMPROPER INSTALLATION. HYDROMATIC RECOMMENDS INSTALLATION BY PROFESSIONALS.

Some states do not permit some or all of the above warranty limitations or the exclusion or limitation of incidental or consequential damages and therefore such limitations may not apply to you. No warranties or representations at any time made by any representatives of Hydromatic shall vary or expand the provision hereof.

 <b>HYDROMATIC®</b>	– Your Authorized Local Distributor –
<b>USA</b>	<b>CANADA</b>
740 East 9th Street, Ashland, Ohio 44805 Tel: 419-289-3042 Fax: 419-281-4087	269 Trillium Drive, Kitchener, Ontario, Canada N2G 4W5 Tel: 519-896-2163 Fax: 519-896-6337
<a href="http://www.hydromatic.com">www.hydromatic.com</a>	

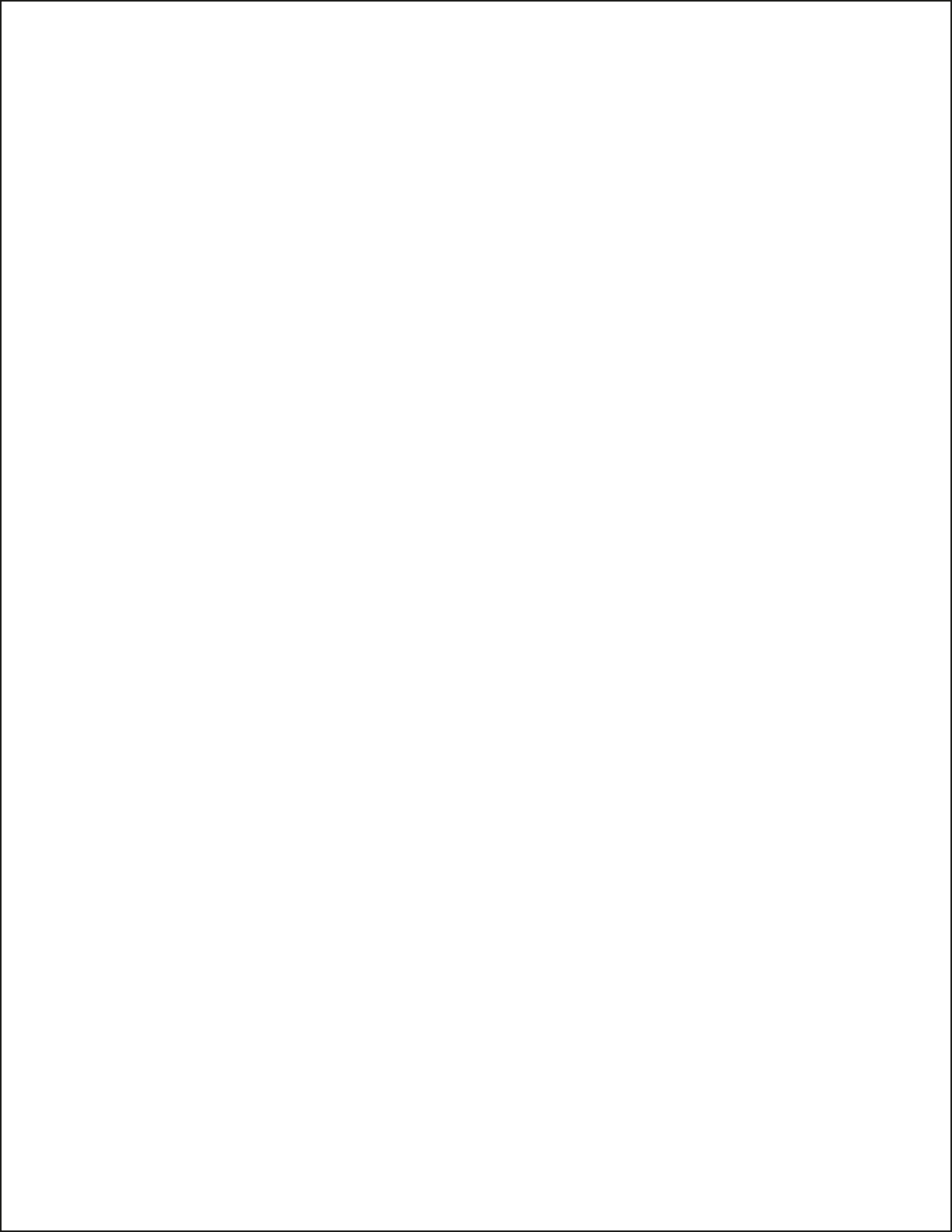

Distributor: \_\_\_\_\_ Order No.: \_\_\_\_\_  
Installing Contractor: \_\_\_\_\_ Phone: \_\_\_\_\_  
Sales Contact: \_\_\_\_\_ Phone: \_\_\_\_\_  
Customer: \_\_\_\_\_  
Location: \_\_\_\_\_

## 1. SYSTEM INFORMATION

Size of Wet Well: \_\_\_\_\_ Manufacturer: \_\_\_\_\_  
Discharge from Bottom of Basin: \_\_\_\_\_ Discharge Location: \_\_\_\_\_  
Inlet from Bottom of Basin: \_\_\_\_\_ Inlet Location: \_\_\_\_\_  
Type of Check Valves: \_\_\_\_\_ Type of Piping: \_\_\_\_\_  
Does System Have Suction Gauges?  Yes  No Suction Pressure Reading: \_\_\_\_\_  
Does System Have Discharge Gauges?  Yes  No Discharge Pressure Reading: \_\_\_\_\_  
Liquid Being Pumped: \_\_\_\_\_ Temperature (F°): \_\_\_\_\_ Pct. of Solid (%): \_\_\_\_\_  
Is a Sketch or Photograph of System Available?  Yes  No *If So, Please Attach.*  
Any Additional Comments on System: \_\_\_\_\_

## 2. ELECTRICAL INFORMATION

Control Panel Part Number: \_\_\_\_\_ Panel Rated Amps: \_\_\_\_\_  
Manufacturer: \_\_\_\_\_ Voltage: \_\_\_\_\_ Phase: \_\_\_\_\_  
Heater Size: \_\_\_\_\_ Location of Panel to Wet Well: \_\_\_\_\_  
Incoming Line Voltage: \_\_\_\_\_ Actual? \_\_\_\_\_  
Voltage to Pumps: \_\_\_\_\_ Actual? \_\_\_\_\_  
Type of Junction Box: \_\_\_\_\_ Manufacturer of Junction Box: \_\_\_\_\_  
Are Floats Installed in Wet Well?  Yes  No Are Floats Set to Engineer's Specs?  Yes  No  
Are Floats Wired for Proper Sequencing?  Yes  No Are Heat Sensors Hooked Up?  Yes  No  
Is the Seal Leak Detection Hooked Up?  Yes  No  
Any Additional Comments on Electrical: \_\_\_\_\_

## 3. PUMP INFORMATION

Type of Pump: \_\_\_\_\_ Serial Number of Pump: \_\_\_\_\_  
Voltage of Pump: \_\_\_\_\_ Phase: \_\_\_\_\_ RPM: \_\_\_\_\_ Amps: \_\_\_\_\_  
Impeller Size: \_\_\_\_\_ C.O.S. TDH: \_\_\_\_\_ GPM: \_\_\_\_\_  
Voltage Supplied from Panel: \_\_\_\_\_ Actual? \_\_\_\_\_  
Actual Amperage (All Phases): Phase 1 Amps: \_\_\_\_\_ Phase 2 Amps: \_\_\_\_\_ Phase 3 Amps: \_\_\_\_\_  
Define the Rotation of the Pump:  Clockwise  Counterclockwise  
Method Used to Check Rotation:  Viewed from the Top  Viewed from the Bottom  
Any Additional Comments on Pumps: \_\_\_\_\_

## 4. ACKNOWLEDGE

Acknowledge that all information is accurate and proper procedures have been followed.

Customer: \_\_\_\_\_ Date: \_\_\_\_\_  
Start-up Technician: \_\_\_\_\_ Date: \_\_\_\_\_

Send to Warranty Manager, 1101 Myers Parkway, Ashland, OH 44805  
or Fax to 419-207-3344

or email to [startupreport@hydromatic.com](mailto:startupreport@hydromatic.com)

or submit online at <http://forms.pentairliterature.com/startupform/startupform.asp?type=h>