

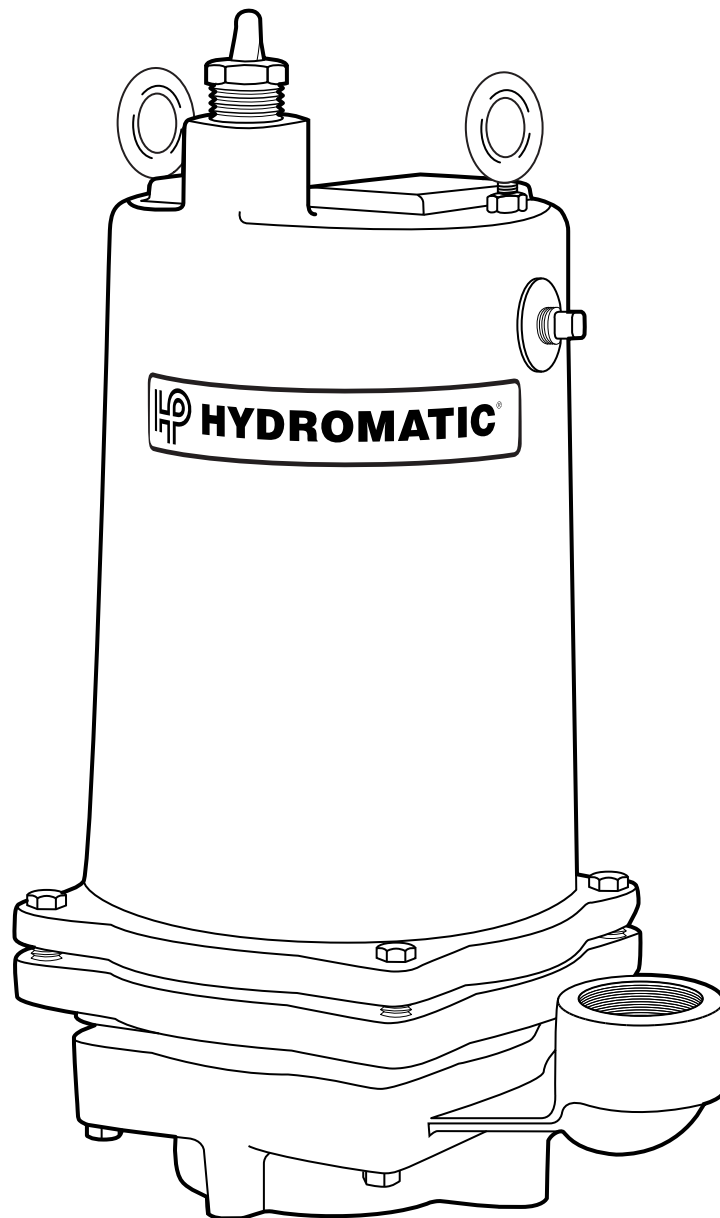

HYDROMATIC®

HPGR200

Submersible Grinder Pump



NOTE! To the installer: Please make sure you provide this manual to the owner of the pumping equipment or to the responsible party who maintains the system.



Pentair
Water™

General Information

Thank you for purchasing your Hydromatic® pump. To help ensure years of trouble-free operation, please read the following manual carefully.

Before Operation:

Read the following instructions carefully. Reasonable care and safe methods should be practiced. Check local codes and requirements before installation.

Attention:

This manual contains important information for the safe use of this product. Read this manual completely before using this product and refer to it often for continued safe product use. **DO NOT THROW AWAY OR LOSE THIS MANUAL.** Keep it in a safe place so that you may refer to it often.

WARNING: Before handling these pumps and controls, always disconnect the power first. Do not smoke or use sparkable electrical devices or flames in a septic (gaseous) or possible septic sump.

Pump Cautions And Warnings

To reduce risk of electrical shock:

1. Risk of Electrical Shock:

This pump has not been investigated for use in swimming pool areas.

2. Risk of Electrical Shock:

Connect only to a properly grounded receptacle.

Septic tank to be vented in accordance with local plumbing codes.

Do not smoke or use sparkable electrical devices or flame in a septic (gaseous) or possible septic sump.

If a septic sump condition may exist and if entry into sump is necessary, then (1) provide proper safety precautions per OSHA requirements and (2) do not enter sump until these precautions are strictly adhered to.

Do not install pump in location classified as hazardous per N.E.C., ANSI/NFPA 70 - 2000.

Failure to heed above cautions could result in injury or death.

1. *CAUTION* - To reduce risk of electrical shock, pull plug before servicing this pump.
2. *WARNING* - Risk of electrical shock - this pump has not been investigated for use in a swimming pool.
3. *WARNING* - SEE installation and service manual for proper installation.
4. *WARNING* - To reduce risk of electrical shock pump is provided with grounding wire. Be certain that it is connected to ground.
5. *WARNING* - Hazardous moving parts. To reduce the risk of injury, disconnect power before servicing pump.
6. *CAUTION* - To reduce the risk of electrical shock, **DO NOT** remove cord or strain relief.

DO NOT connect conduit to pump. Electrical installations shall be in accordance with the National Electrical Code and all applicable local codes and ordinances. This marking is required on 3 phase models only.

7. *CAUTION* - For use with maximum 140°F water.
8. *CAUTION* - Tank should be vented in accordance with local plumbing codes and should not be installed in locations classified as hazardous, in accordance with the National Electrical Code, ANSI/NFPA 70-1999.
9. *CAUTION* - Risk of electrical shock. Do not remove cord and strain relief. Do not connect conduit to pump.
10. *WARNING* - Severe injury may result from accidental contact with moving cutters. Keep clothing, hands and feet away from cutters any time power is connected to the pump.
11. *CAUTION* - Never work on pump with power on. Make sure that the ground wire is securely connected and that the unit is properly grounded in accordance with local codes.

Pump Installation

Installing Pump in Sump:

Before installing pump in sump, lay it on its side and rotate impeller. Impeller may be slightly stuck due to factory test water so it must be broken loose with a small bar or screwdriver in edge of vanes. The impeller should turn freely. Do not connect the power until after this test.

Clean all trash and sticks from sump and connect pump to piping.

A check valve must be installed on each pump.

Location:

If pumps are installed in an existing basin or concrete sump, the piping can either be connected permanently or rails and brackets can be furnished for mounting to walls of basin. In either case, be sure that the Hydromatic nonclog check valve is used and that the pumps are submerged in a vertical position. The complete factory-built packaged system is recommended for the most satisfactory installation and generally for the lowest cost where expensive installation labor is involved.

Making Electrical Connections:

All electrical wiring must be in accordance with local code, and only qualified electricians should make the installations. Complete wiring diagrams are included for use in making the installation. All wires should be checked for shorts to ground with an ohmmeter or Megger after the connections are made. This is important, as one grounded wire can cause considerable trouble.

Pump Operation

Starting the Pump:

WARNING: Severe injury may result from accidental contact with moving cutters. Keep clothing, hands and feet away from cutters any time power is connected to the pump.

To start the pump, perform the following steps in order:

1. Grinder pump is single phase; no rotation check is necessary.
2. Run water into sump until motor is covered.
3. Open gate valve in discharge line.
4. Turn pump on. If pump runs and sump liquid does not pump down, stop pump and close discharge gate valve. Then lift pump until sealing flange is open to vent off trapped air. Lower pump, open discharge valve, and start the pump again.
5. Level control should be set so that pump turns off when level is about 2 inches above inlet of pump suction and turns on when level is about 2 inches above motor.
6. If problems occur check power source. Make sure a separate supply line is available. Verify voltage supply.
7. Check resistance of windings. (See Chart, page 5.) If not within guidelines, return pump to authorized Hydromatic service or repair center.

As the motors are oil filled, no lubrication or other maintenance is required. Pump should be checked every quarter for corrosion and wear.

Pump Servicing

Read the following instructions carefully before replacing any parts. Reasonable care and safe methods should be practiced. Check local codes and requirements before installation. Only a competent electrician should make the installations.

CAUTION: Never work on pump with power on. Make sure that the ground wire is securely

connected and that the unit is properly grounded in accordance with local codes.

CAUTION: Severe injury may result from accidental contact with moving cutters. Keep clothing, hands and feet away from cutters any time power is connected to the pump.

Replacing Grinder Parts:

If necessary to replace grinder parts because of wear or to inspect for clogging:

1. Close gate valve at pump discharge.
2. Turn off circuit breaker.

CAUTION: Never work on pump with power on. Be sure ground wire from pump is connected to a good ground such as a water pipe.

3. Remove pump from sump.
4. Unscrew screws (17) and remove cutter ring retainer (16). Stationary cutter (15) cannot be removed from volute (20).
5. Unscrew hex head cap screws (12) and remove volute case (20).
6. Radial cutter (13) and axial cutter (14) are now exposed. If checking for clogging, these parts can now be cleaned without removing them from the shaft.
7. If necessary to replace cutters, remove screw (19), washer (18), and radial cutter (13) from shaft. Radial cutter (13) and impeller (9) are screwed onto shaft. The thread is right-hand. Tap radial cutter (13) with plastic hammer if necessary to loosen. Axial

- cutter (14) lifts off impeller (9) and is held from rotation by pin. Unscrew impeller (9) from shaft in same manner as radial cutter (13).
- Clean all parts thoroughly before proceeding with assembly. Replace case (20), but do not replace cutter ring (15) at this point.
 - Replace cutter ring (15) and cutter ring retainer (16). Screw down with screws (17).
 - Plug pump into power and operate for a few seconds only to ensure parts are not rubbing.

Replacing Seal:

- Drain the oil from the pump by removing the fill plug (5) located on the side of the motor housing (7).
- Remove the volute and cutters per the instructions listed under the replacing grinder parts section in this manual.
- To remove the impeller (9), secure the shaft by a flat bladed screwdriver into slot on end of the shaft. Hold a wood block against the impeller vane and tap it with a hammer until it spins off.
- Remove the seal (24) rotating elements by sliding the spring bellows off the shaft, then using two screwdrivers, slide the carbon seal assembly off by prying on the retaining ring.
- Using a screwdriver, break the old stationary portion of the seal (24) to allow for removal.
- Take the stationary portion of the new seal (24), and lube the rubber material with good quality dielectric oil. Press the stationary portion of the new seal into the seal/bearing plate (21).

CAUTION: Do not reuse old seal parts. Replace all parts with new. Mixing old and new parts could cause immediate seal failure.

- Using a good quality dielectric oil, lube the rubber material on the carbon seal assembly (24) and press it on the shaft. Place the spring bellows on the shaft as removed.
- Using a pressure gauge with a fill stem, pressurize the motor housing no more than 7 psig with dried air and check for leaks. If after several minutes the gauge reads the same, the seal is good and you can continue with assembly.

NOTE: It is normal to observe some air bubbles in the seal area initially as the seal seats. If bubbles do not stop within a few seconds, the seal is either not properly installed or is damaged.

- Reassemble the cutter and volute as outlined in the replacing grinder parts section of this manual.
- Refill motor housing with a good quality paraffinic oil (25). Fill the motor housing so that the tops of the motor windings have been covered, but leave an air gap to allow for expansion of the oil.

NOTE: When applying power, be sure the pump is restrained from turning by holding the pump at the motor housing, or by clamping it in a holding fixture.

WARNING: Severe injury may result from accidental contact with moving cutters. Keep clothing, hands and feet away from cutters any time power is connected to the pump.

PERFORMANCE CURVE

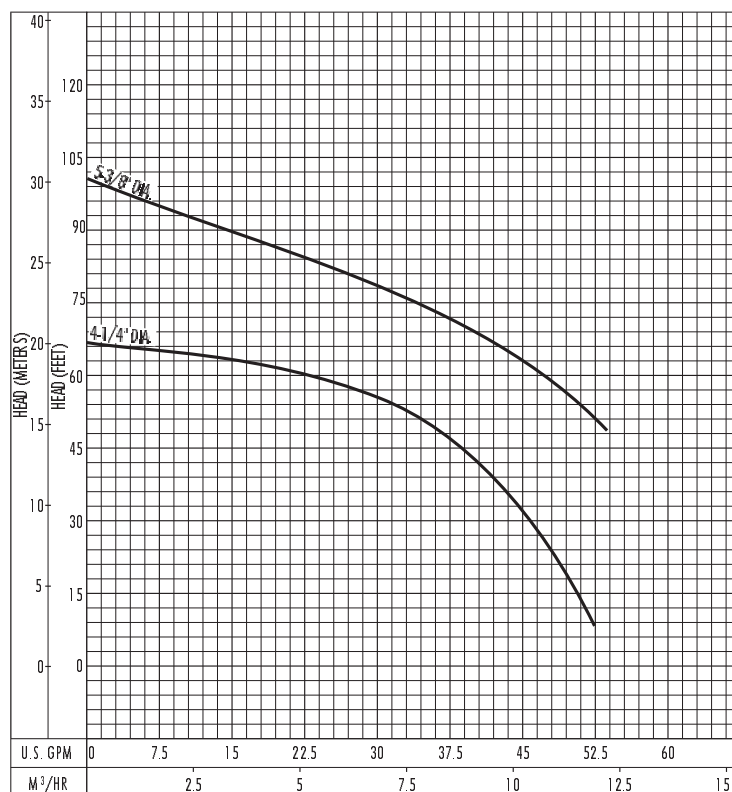

Pump Troubleshooting

Below is a list of troubles and their probable causes:

No liquid delivered

1. Pump airbound
2. Discharge head too high
3. Pump or piping plugged
4. Speed too low

Insufficient liquid delivered

1. Discharge head too high
2. Impeller or cutters partially plugged or damaged
3. Incorrect impeller diameter
4. Speed too low

Insufficient discharge pressure

1. Air or gases in liquid
2. Impeller damaged
3. Incorrect impeller diameter
4. Speed too low

Pump overloads motor

1. Specific gravity or viscosity of liquid too high
2. Speed too high
3. Head lower than rating, pumping too much liquid
4. Pump clogged
5. Defective bearings
6. Defective impeller

Pump is noisy

1. Defective bearings
2. No axial clearance between impeller and volute

3. No diametral clearance between radial cutter and cutter ring

If the cause of the trouble cannot be determined and

corrected as outlined above, contact your nearest factory representative.

Start Windings	7.53
Run Windings	1.56

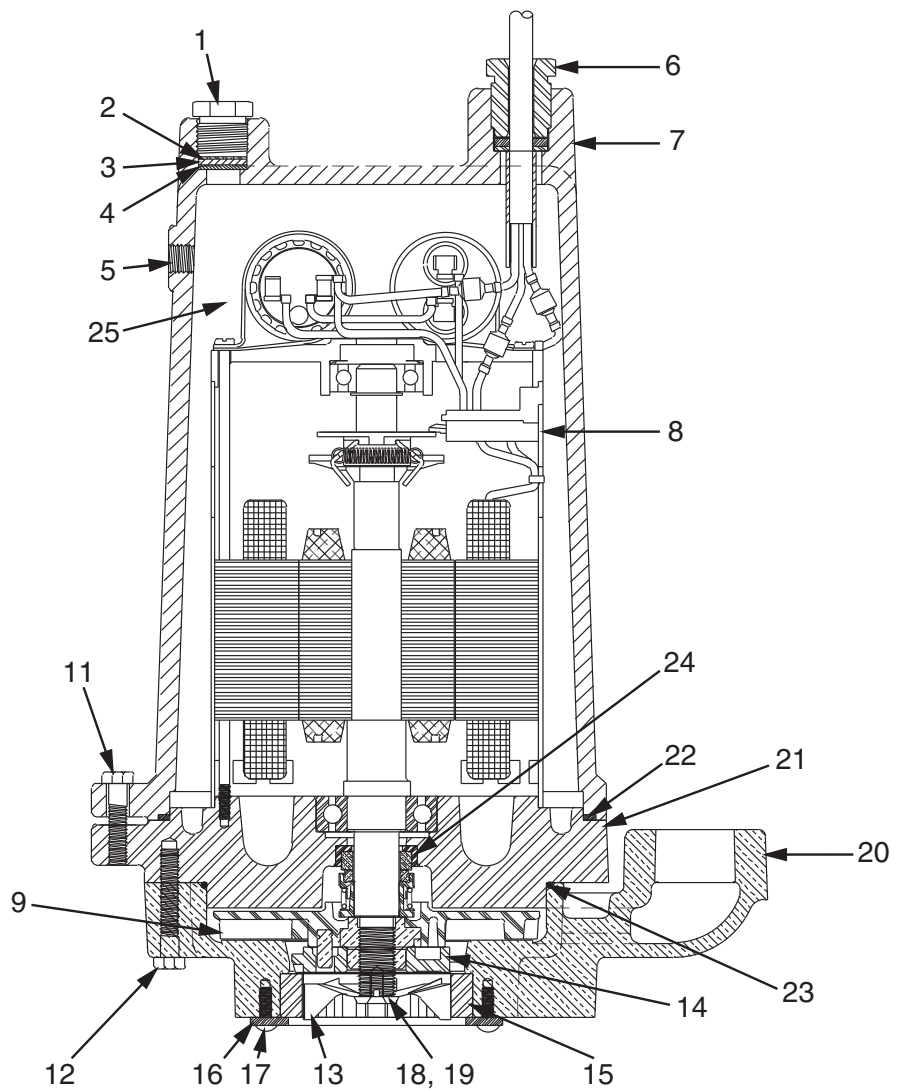

HPGR200 Typical Installation



HPGR200 Parts List

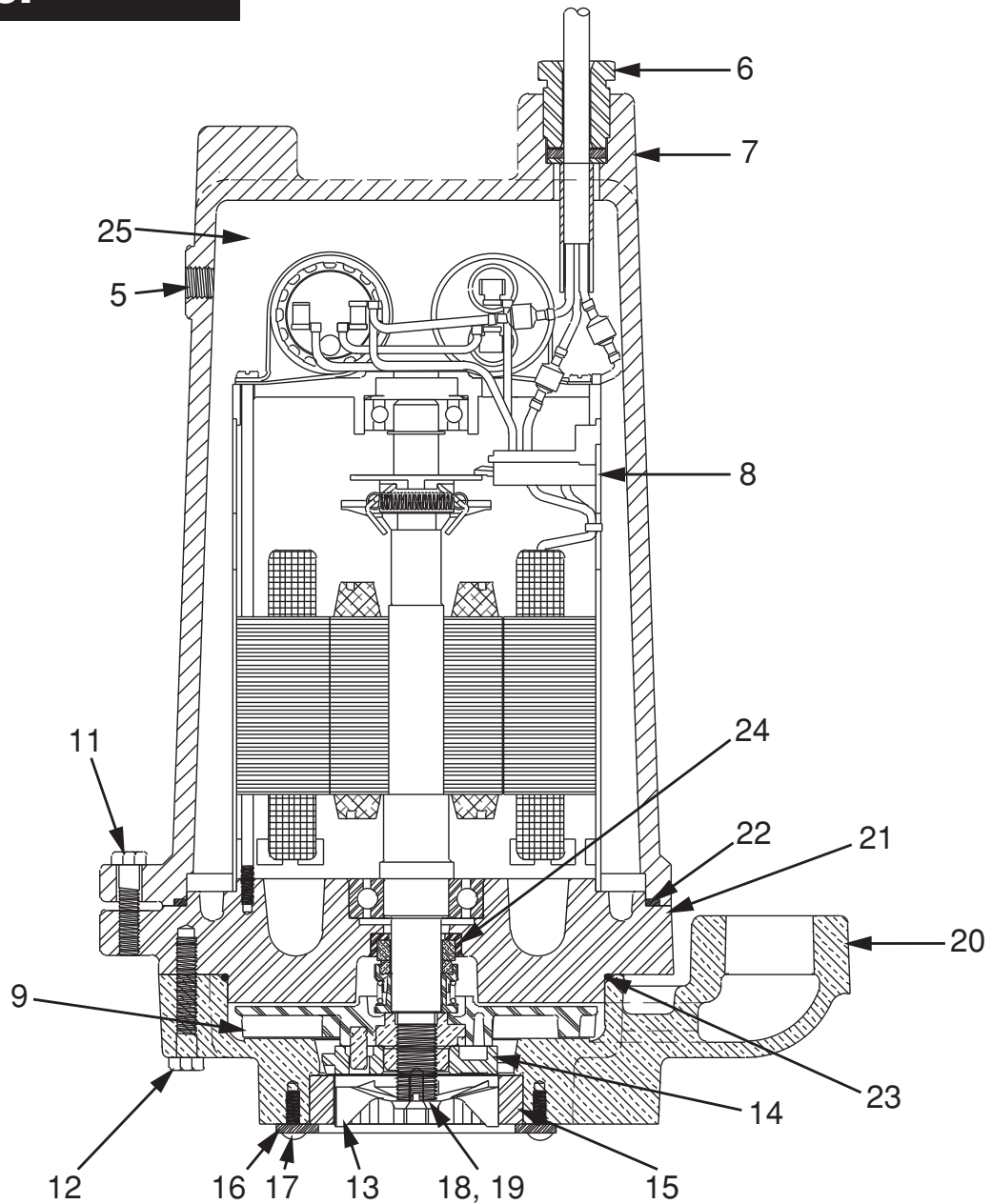

Ref. No.	Part No.	Description	Qty.	Ref. No.	Part No.	Description	Qty.
5	14981-001-1	Oil Fill Plug	1	19	14885-000-1	Impeller Screw	1
6	25338B001	Power Cord	1	20	10957-000-2	Volute	1
7	14589-002-2	Motor Housing	1	21	14569-000-1	Bearing Housing	1
8	14570-000-1	Motor	1	22	00077-011-1	O-ring	1
9	07033-020-3	Impeller	1	23	00834-023-1	O-ring	1
10				24	14573-000-1	Shaft Seal	1
11	00101-008-1	Screw	4	25	24709110000	Paraffinic Oil	0.90
12	00101-011-1	Screw	4	NOT	00589-002-1	Eye Bolt	2
13	05405-001-2	Radial Cutter	1	SHOWN	01032-002-1	Hex Nut	2
14	05506-002-2	Axial Cutter	1			For Automatic Operation	
15	05505-000-2	Stationary Cutter	1	NOT	14595-020-1	Wide Angle Switch 20'	
16	07763-000-1	Cutter Retainer	1	SHOWN			
17	00030-004-1	Screw	3				
18	05570-005-1	Impeller Washer	1				

LIMITED WARRANTY

HYDROMATIC warrants to the original consumer purchaser ("Purchaser" or "You") of HYDROMATIC Sump Pumps, Effluent Pumps, Sewage Pumps (other than 2-1/2"), and Package Systems, that they will be free from defects in material and workmanship for the Warranty Period of 36 months from date of manufacture.

Our warranty will not apply to any product that, in our sole judgement, has been subject to negligence, misapplication, improper installation, or improper maintenance. Without limiting the foregoing, operating a three phase motor with single phase power through a phase converter will void the warranty. Note also that three phase motors must be protected by three-leg, ambient compensated, extra-quick trip overload relays of the recommended size or the warranty is void.

Your only remedy, and HYDROMATIC's only duty, is that HYDROMATIC repair or replace defective products (at HYDROMATIC's choice). You must pay all labor and shipping charges associated with this warranty and must request warranty service through the installing dealer as soon as a problem is discovered. No request for service will be accepted if received after the Warranty Period has expired. This warranty is not transferable.

EXCEPTIONS: Hydromatic Special Application Pumps, Battery Back-Up Sump Pumps, Filtered Effluent Pumps, Grinder Pumps, and 2-1/2" Sewage Pumps are warranted for a period of 12 months from date of purchase or 18 months from date of manufacture, whichever comes first.

HYDROMATIC SHALL NOT BE LIABLE FOR ANY CONSEQUENTIAL, INCIDENTAL, OR CONTINGENT DAMAGES WHATSOEVER.

THE FOREGOING WARRANTIES ARE EXCLUSIVE AND IN LIEU OF ALL OTHER EXPRESS AND IMPLIED WARRANTIES, INCLUDING BUT NOT LIMITED TO THE IMPLIED WARRANTIES OF MERCHANTABILITY AND FITNESS FOR A PARTICULAR PURPOSE. THE FOREGOING WARRANTIES SHALL NOT EXTEND BEYOND THE DURATION EXPRESSLY PROVIDED HEREIN.

Some states do not allow the exclusion or limitation of incidental or consequential damages or limitations on the duration of an implied warranty, so the above limitations or exclusions may not apply to You. This warranty gives You specific legal rights and You may also have other rights which vary from state to state.

This warranty supersedes and replaces all previous warranty publications.

HYDROMATIC

740 East 9th Street, Ashland, OH 44805

Phone: 888-957-8677 • Fax: 888-840-7867 • Web Site: <http://www.hydraulic.com>

– Your Authorized Local Distributor –



HYDROMATIC®

Pentair Water

USA

740 East 9th Street, Ashland, Ohio 44805

Tel: 888-957-8677 Fax: 888-840-7867

www.hydraulic.com

CANADA

269 Trillium Drive, Kitchener, Ontario, Canada N2G 4W5

Tel: 519-748-5470 Fax: 519-748-2553