

Installation and Service Manual

SUBMERSIBLE PUMP WITH HAZARDOUS LOCATION MOTOR END

Models **S4TX, S8LX, S8LAX** and **S12LX**

(Class I, Division 1, Groups C & D): FM

(Hazardous Location
Motor End)



NOTE! To the installer: Please make sure you provide this manual to the owner of the equipment or to the responsible party who maintains the system.

**For use with product
built with USEM motor.**

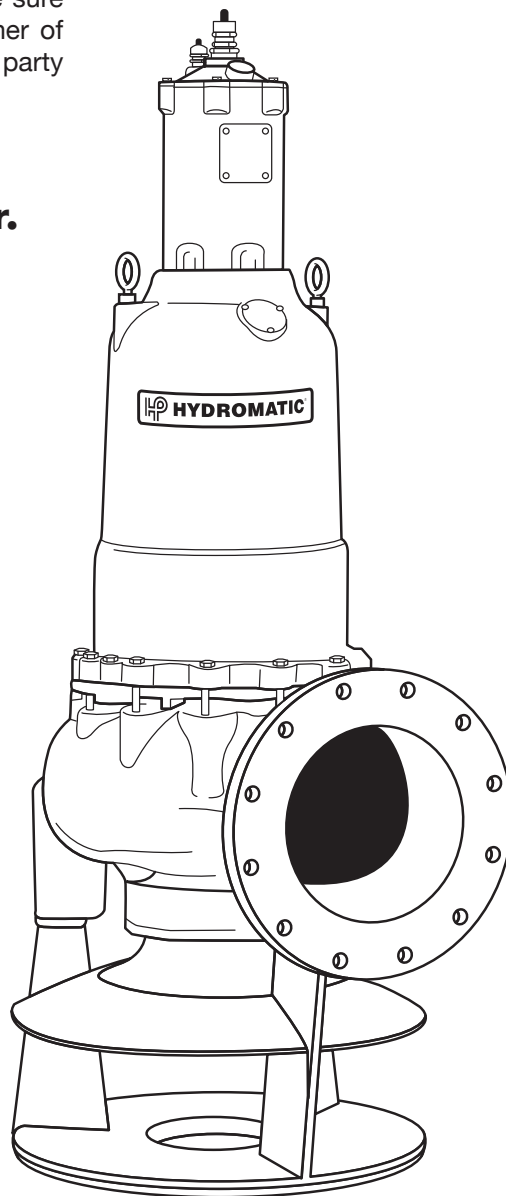

HYDROMATIC[®]
Pentair Water

02/11
Item # E-03-506
Part # 5625-506-1
© 2011 Pentair Pump Group, Inc.

General Information

Thank you for purchasing your Hydromatic® pump. To help ensure years of trouble-free operation, please read the following manual carefully.

Before Operation:

Read the following instructions carefully. Reasonable care and safe methods should be practiced. Check local codes and requirements before installation.

Attention:

This manual contains important information for the safe use of this product. Read this manual completely before using this product and refer to it often for continued safe product use. **DO NOT THROW AWAY OR LOSE THIS MANUAL.** Keep it in a safe place so that you may refer to it often.

Unpacking Pump:

Remove pump from carton. When unpacking unit, check for concealed damage. Claims for damage must be made at the receiving end through the delivery carrier. Damage cannot be processed from the factory.

WARNING: Before handling these pumps and controls, always disconnect the power first. Do not smoke or use sparkable electrical devices or flames in a septic (gaseous) or possible septic sump.

IMPORTANT: Read all directions before replacing any parts.

Pump:

The hazardous location submersible pump family was designed in accordance with requirements for hazardous locations. These pumps, if connected properly, will provide years of trouble-free service. If servicing is required, the repair should be done by a Hydromatic approved service center.

Pumps in Storage or Not Operating:

Pumps with carbon ceramic seals must have impellers manually rotated (6 revolutions) after setting non-operational for 3 months or longer and prior to electrical start-up.

Pumps with tungsten carbide seals must have impellers manually rotated (6 revolutions) after setting non-operational for 3 weeks or longer and prior to electrical start-up.

Seal Failure Probes:

All hazardous location submersible pumps have two factory installed moisture detectors (seal failure probes). They are in a normally open series circuit, in the seal chamber. Under normal operating conditions, the circuit remains open. If the lower seal leaks and moisture enters this chamber, the moisture would settle to the bottom of the chamber and will complete the circuit between the moisture detectors.

This circuit must be connected to a sensing unit and signaling device. This is supplied in a Hydromatic built control panel.

NOTE: Failure to install such a device negates all warranties by Hydromatic pumps.

Heat Sensors:

All motors in this family have heat sensors on or embedded in the motor winding to detect excessive heat. This prevents damage to the motor. If sensor trips due to excessive winding temperature, starter in panel breaks power to the pump. Once sensor resets, the starter is to be automatically reset for FM for continued operation of the pump. This circuitry is supplied in a Hydromatic control panel.

The sensors are set to trip at 150°C (302°F).

NOTE: Failure to install such circuitry would negate FM approvals and all warranties by Hydromatic pumps.

Power Cords:

The power cord and heat sensor seal failure cord are potted into the connection box cap. The cords must not be spliced.

NOTE: Each cable has a green lead. This is the ground wire and must be grounded properly per NEC and/or local codes. Cords should be inspected for abnormal wear and replaced accordingly.

Overload Heaters:

If the Hydromatic electrical panel is not used, starters with 3 leg overload relay must be supplied on 3 phase pumps. Each leg is to have an identical heater sized in accordance with the nameplate amps on the motor housing. The amp draw on these submersible motors is slightly higher than a corresponding horsepower surface motor, so heaters must be sized by the nameplate rating. To adequately

protect these windings with the appropriate heaters, consult the factory.

NOTE: Red lead is always start winding of pump using single phase.

Pump Installation

Installing Sump Level Control Float Controls:

In either simplex, duplex or triplex systems the lower or turn-off control is to be set to maintain a minimum level in the sump. This level shall be no more than 3/4" from the top of the motor housing down to the surface of the sewage.

The second or turn-on control is set above the lower turn-off control. The exact distance between the two floats must be a compromise between a frequent pumping cycle (10 starts per hour max.) to control septicity, solids and a slower cycle for energy economy. This distance should be determined by the engineer or consulting engineer depending on the conditions of the application.

For installation of Hydromatic supplied level controls refer to your systems installation and service manual.

Installing Pump in Sump:

Before installing pump in sump lay it on side and rotate impeller. Impeller may be slightly stuck due to factory test water so it must be broken loose with small bar or screwdriver in edge of vanes. The impeller should turn freely. *Do not connect the power until after this test.*

Clean all trash and sticks from sump and connect pump to piping. A check valve must be installed on each pump. A gate or plug valve in each pump discharge is highly recommended. This valve should be installed on the discharge side of the check valve so if necessary to service the check valve the line pressure can be cut off. Single pump systems are sometimes installed without a check valve where it is desirable to self-drain the discharge line to prevent freezing. This can be done only with short discharge lines; otherwise water will return to the sump and cause short cycling of the pump.

Making Electrical Connections:

All electrical wiring must be in accordance with local code, and only qualified electricians should make the installations. Complete wiring diagrams are included for use in making the installation. All wires should be checked for shorts to ground with an ohmmeter or Megger after the connections are made. This is important, as one grounded wire can cause considerable trouble.

IMPORTANT: If equipment is not properly wired and protected as recommended, Hydromatic warranty is void. See Page 4.

Heat Sensor and Seal Failure Connections:

If a Hydromatic control panel is used, terminal blocks are provided for heat sensor, seal failure connections (See Panel Schematic). If a control panel is supplied by others, it must allow heat sensor and seal failure terminations.

Pump Operations

Starting System:

1. Double check all wire connections.
2. Turn pumps to Off position on H-O-A switches.
3. Turn on breakers.
4. Turn H-O-A switch to Hand position on one pump and notice operation. If pump is noisy and vibrates, rotation is wrong. To change rotation, interchange any two line leads to pump. Do not interchange main incoming lines. Check rotation of all pumps in this same manner.
5. Now set both H-O-A switches to Auto position and allow water to rise in sump until one pump starts. Allow pump to operate until the level drops to turn-off point.
6. Allow sump level to rise to start other pump(s). Notice run lights to panel. Pumps should alternate on each successive cycle of operation.
7. Turn both H-O-A switches to Off position and allow sump to fill to the override control level(s).
8. Turn switches to Auto position, and pumps should start and operate together until level drops to turn-off point.
9. Repeat this operation cycle several times before leaving job.
10. Check voltage when pumps are operating, and check the amp draw of each pump. Check amps on each wire as sometimes a high leg will exist. One leg can be somewhat higher by 5 to 10 percent without causing trouble. For excessive amp draw on one leg, the electric utility company should be consulted.

Typical FM Only Schematics

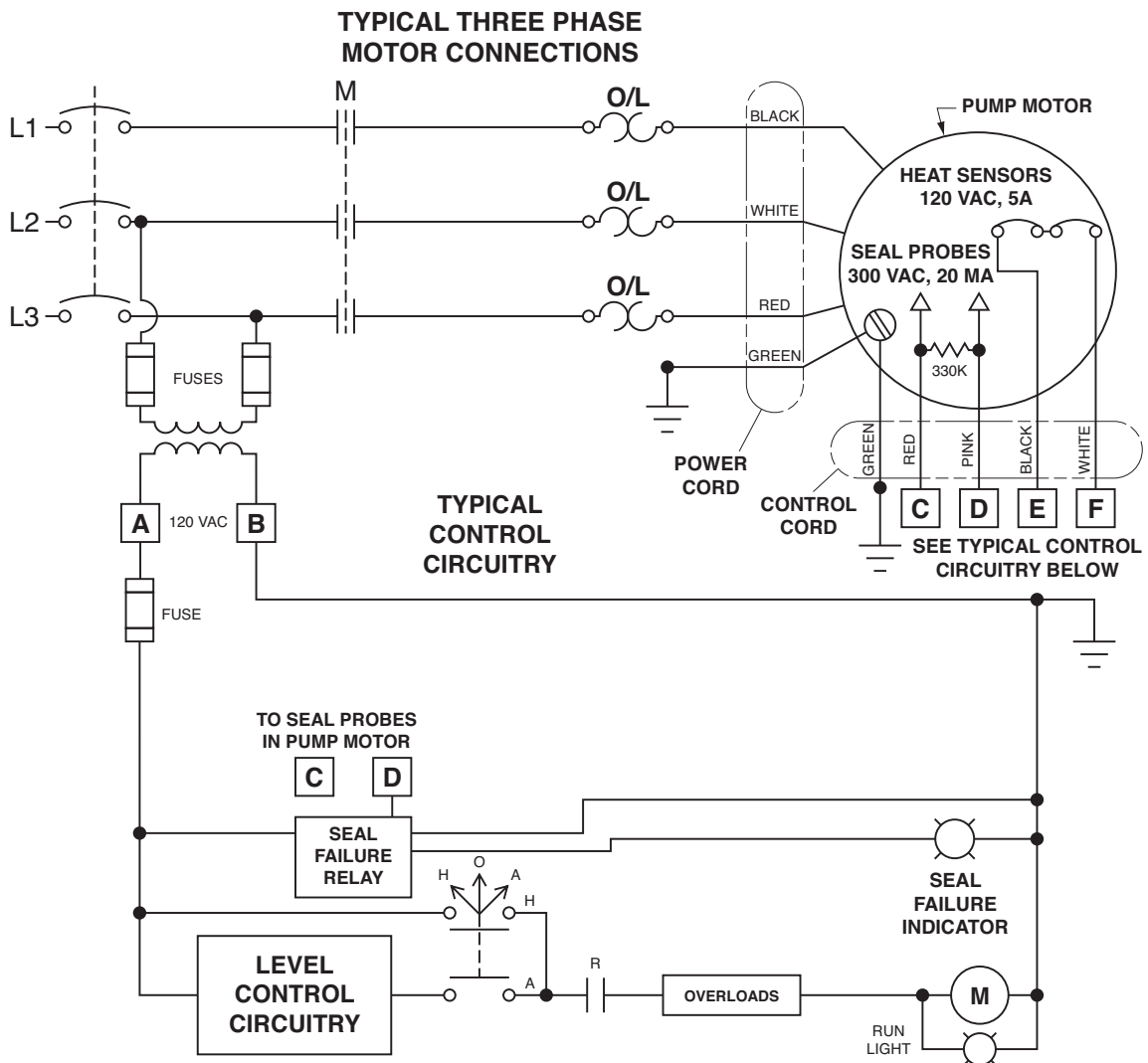

Wiring Diagrams

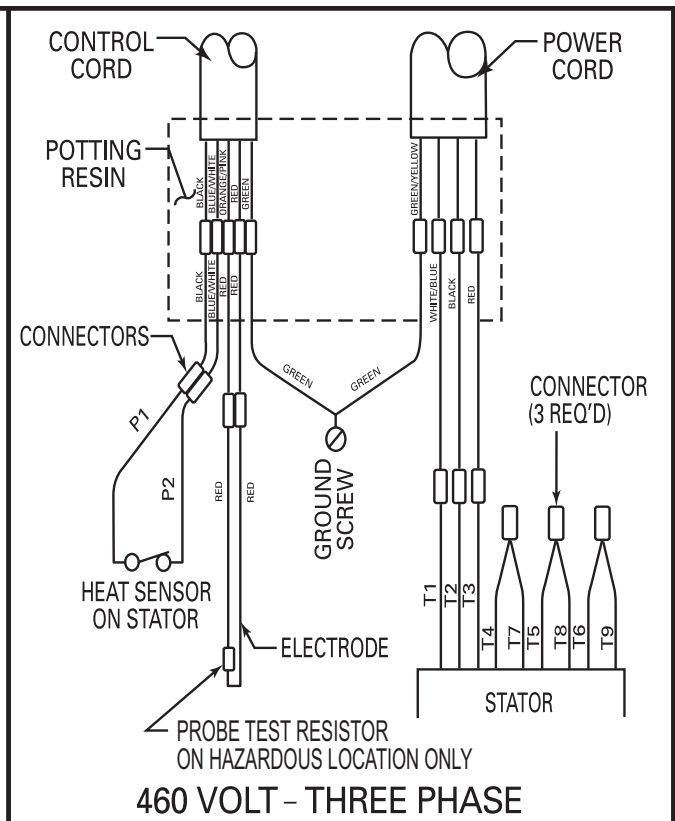
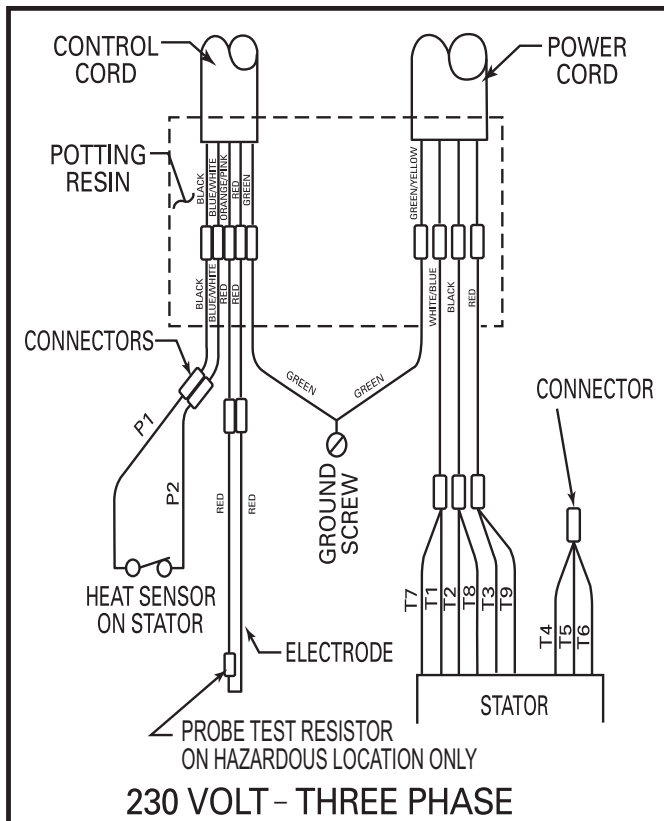
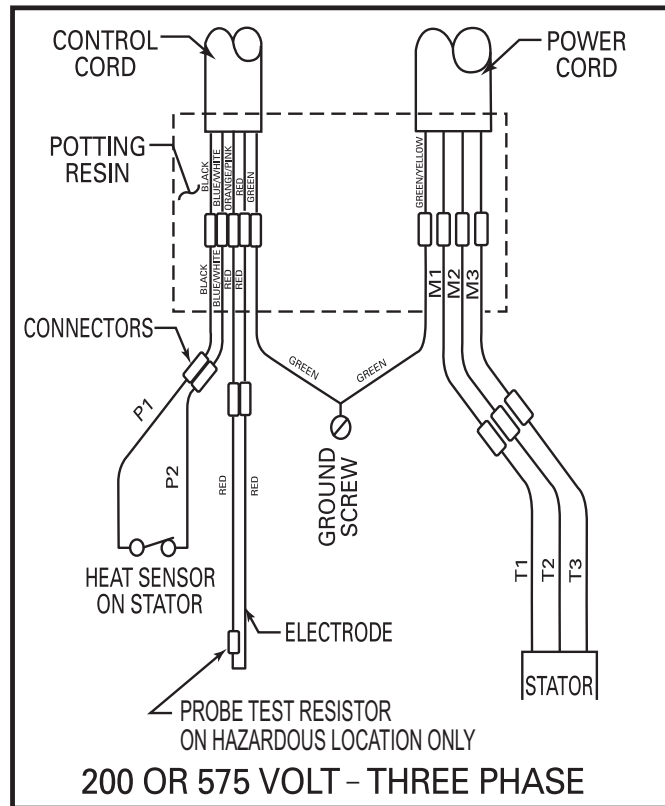

Pump Maintenance

NOTE: Any unauthorized field repair voids the warranty, the hazardous location rating, and Factory Mutual approval.

As the motors are oil filled, no lubrication or other maintenance is required.

If the heat sensor and seal failure are hooked up properly, no attention is necessary as long as the seal failure indicator light doesn't come on. To ensure continuity of the seal sensor leads, a test light is provided on intrinsically safe Hydromatic panels as standard equipment.

Pump should be checked every quarter for corrosion and wear.

Servicing Instructions:

IMPORTANT: Read all directions before replacing any parts.

WARNING: Before handling these pumps and controls, always disconnect the power first.

Do not smoke or use sparkable electrical devices or flames in a septic (gaseous) or possible septic sump.

Field Service on Hydromatic Hazardous Location Pumps:

If a Hydromatic hazardous location pump is used in a hazardous location, or if the pump is still in warranty, the pump must be returned to the factory for service or repaired in an authorized Factory Mutual Hydromatic service center.

Charges will not be allowed if (in warranty) the pump is taken to a motor repair shop that is not an authorized Factory Mutual Hydromatic service center. This will ensure the integrity of the hazardous location rating of the pump and comply with our warranty requirements. Pumps out of warranty and not used in a hazardous location can be field serviced by any reputable serviceman. When any field servicing is performed on a pump, the following instructions should be followed carefully.

Disconnecting Pump Cords:

If a Hydromatic hazardous location pump is to be removed from its location, one of two ways may be used to disconnect the pump cords from the rest of the system.

Pump cords may be disconnected at control panel (on sump mounted control panels) and cord assembly taken with pump.

CAUTION: If cord openings from sump to control panel are open, gases from sump could enter panel and an explosive condition could exist.

Pump cords may be disconnected at pump by removing the cord and cap assembly, unplugging sensor wires, and removing wire nuts.

After removal from pump, reinstall wire nuts in cord and cap assembly.

CAUTION: Do not reconnect power to a cord and cap assembly while removing from pump.

Replacing Cords:

The power cord and heat sensor - seal failure cord is potted into the connection box cap, forming the cord and cap assembly.

If cords require replacement due to damage or cords being too short, cord and cap assembly must be replaced as a complete assembly available from factory.

1. Remove cord and cap assembly from connection box.
2. Disconnect wires taking note of color/number coding.
3. Connect wires of new cord and cap assembly in same manner as the old one was removed.
4. Check for moisture and dryout.
5. Reinstall cord and cap assembly on connection box taking care not to pinch wires.
6. Check pump for proper rotation before returning to normal service.

Replacing Stator:

If motor winding is burned or shorted, it can be rewound or replaced with new factory wound

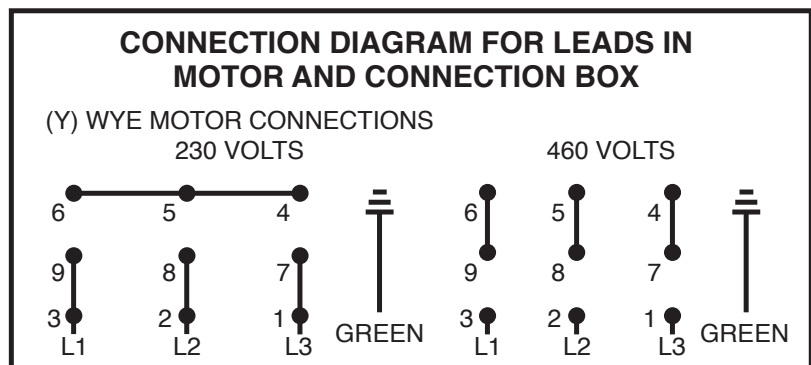

Pump Maintenance

stator. Refer to sectional drawing of pump and motor, and use the following steps to remove and replace stator.

1. If only the stator is damaged, it may not be necessary to completely dismantle pump as stator and housing can be lifted from pump without disturbing seals or bearings.
2. Drain all oil from upper housing. Remove drain plug in bottom of bearing housing, and remove connection box to allow air to enter.
3. When connection box is lifted off, connection wires to motor will be exposed. These wires are tagged with a metal marker giving wire number. Disconnect wires and remove connection box.
4. After chamber is drained, remove hold-down bolts on motor housing and lift off. Use care in lifting as the seal failure connecting wire must be disconnected before housing is completely removed. See sectional drawing.
5. The stator is held in the housing with a bolted-in retaining ring and prevented from rotating by a square key.
6. Remove the retaining ring and socket head cap screw.
7. After ring is removed, turn housing upright and bump on hardwood block. This should jar the stator loose and allow it to drop out.
8. Thoroughly clean housing before replacing new stator. Replace stator and make all wire connections to connection box before replacing housing

on pump. See motor lead connection drawing. This is important as leads must be tucked behind the windings by using hands up through rotor core.

IMPORTANT: Use only butt connections on the wires.

Do not tape leads as oil will deteriorate the tape and cause damage to stator and bearings.

9. Check top bearing. If the bearing is clean and does not turn rough, bearings can be reused. If bearings are damaged with dirt or heat, they must be replaced. See additional instructions on replacing seals and bearings.

10. Replace stator housing onto seal chamber and bolt in place. Be sure seal failure wires are connected before housing is assembled.

Be sure O-ring seal has been replaced. If O-ring is nicked or cut, replace with new ring. This applies to all O-rings used in assembly.

11. After all leads are reconnected in the connection box, make a high voltage ground test on each wire. The only wire that should show ground is the green power lead and the ground head in the auxiliary control cable.

12. For safety, complete pump should be air checked under water for leaks.

Install air valve in plug opening of motor housing and charge housing with about 10 psi of air. Be sure air is dry. Do not use air line where water may be trapped in the line. Submerge complete unit under water and check for leaks.

If seals were okay, refill seal chamber with oil. Lay pump on side for this oil filling with oil fill hole upright. Do not completely fill; leave oil about 1" below plug hole. Use only Hydromatic submersible oil or high grade transformer oil in this chamber. Replace plug; use Permatex on threads.

13. Refill motor chamber with oil through connection box opening. Use high grade, non-synthetic transformer oil or Hydromatic special submersible oil. Fill housing until oil covers top of windings. Leave air space in top for expansion.

NOTE: Oil must cover top of stator.

Replacing Seals and Bearings:

1. Drain all oil from motor chamber and seal chamber as described.
2. Remove motor housing as described in replacing stator.
3. Remove bolts that hold bearing housing to volute. Lift bearing housing and rotating unit off and set assembly on its side. Remove socket head screw and washer at the impeller end of the shaft. Holding the shaft stationary, remove the impeller from the shaft by tapping the end of the impeller blades.
4. To remove seal plate take out socket head screws and using pry plate loose. This will also force seal off if not already removed.
5. Remove snap ring. Pull seal if it is free. If not free, it can be forced off when shaft is removed. The labyrinth ring must also be removed.

6. Set seal housing in upright position and bump end of shaft on hardwood block. This will push the bearing from the housing and will force upper seal from shaft.
7. Use bearing puller to remove bearings. Replace with new bearings. Press only on inner face of bearing when replacing. Pressing on outer face can damage the bearing. Bearings are standard size that can be obtained from any bearing supply house or can be obtained from Hydromatic factory.

8. **IMPORTANT:** Do not use any of the old seal parts. Replace with all new seals.

NOTE: Any time seal is disturbed, replace seal.

9. Thoroughly clean all castings before replacing seals. One grain of dirt between the seal faces can cause failure.

NOTE: The labyrinth ring must be installed with the groove facing OPE.

10. Examine all O-rings for nicks before reusing.
11. Use Loctite[®] (red) on socket head locking screw in end of shaft.
12. Before refilling chamber with oil, air test as described in replacing stator.
13. Refill both chambers with oil as described in replacing stator.
14. Always check all leads with high voltage or with Megger for grounds before operating the pump.
15. Check pump for proper rotation before returning to normal service.

Pump Notes

Motor End Parts

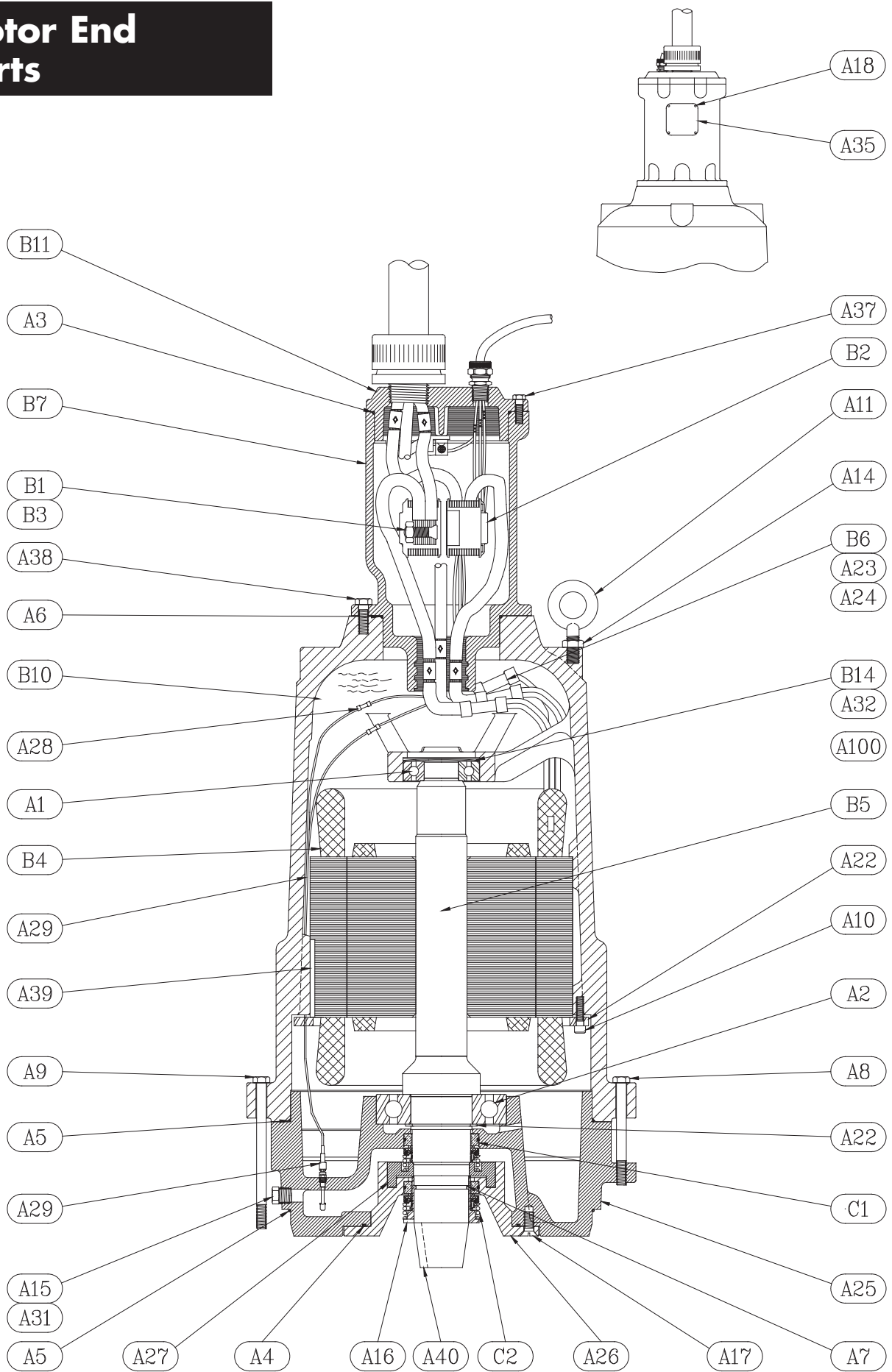

Wet End Parts

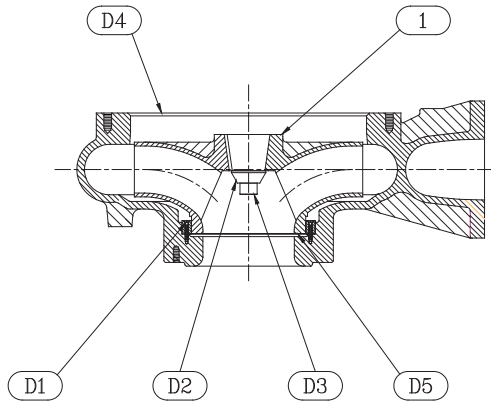

S4TX

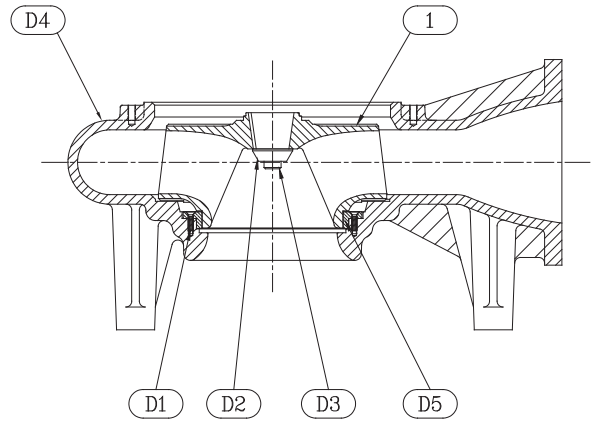

S8LX

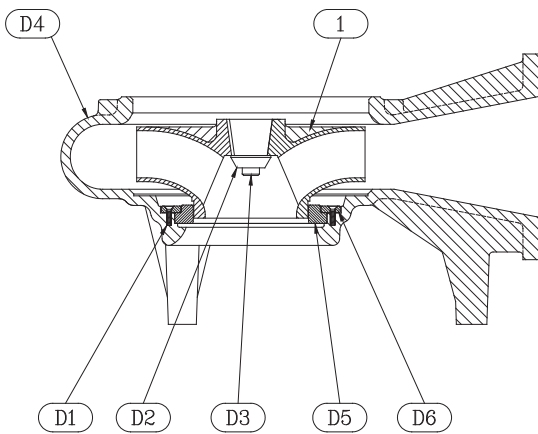

S8LAX

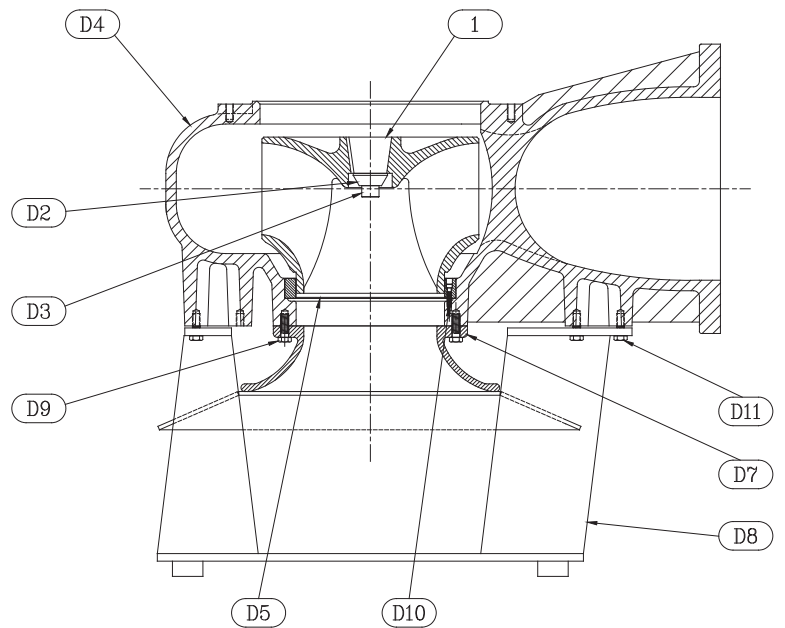

S12LX

Motor Parts List For use with product built with USEM motor.

ORDERING REPLACEMENT PARTS: Product improvements are made from time to time. The latest part design will be furnished as long as it is interchangeable with the old part. When ordering replacement parts, always furnish the following information: (1) pump serial number, (2) pump model and size, (3) part description, (4) part number, (5) impeller diameter (if ordering impeller), (6) quantity required, and (7) shipping instructions.

Ref. No.	Part No.	Part Description	Qty.
A1	65-006-1	BEARING-BALL (UPPER)	1
A2	65-023-1	BEARING-BALL (LOWER)	1
A3	150-019-1	O-RING 6.734 I.D.	1
A4	150-021-1	O-RING 7.734 I.D.	1
A5	150-038-1	O-RING 14.984 I.D.	2
A6	150-042-1	O-RING 5.359 I.D.	1
A7	150-108-1	O-RING 2.484 I.D.	1
A8	239-024-1	SCREW-HHC 1/2-13	4
A9	239-026-1	SCREW-HHC 1/2-13	12
A10	556-007-1	SCREW-HEX SOC. 3/8 x 1-1/2	6
A11	589-004-1	BOLT-EYE	2
A12	1664-008-1	PLUG-PIPE 3/8 BRASS	1
A13	975-014-1	RING-RETAINING	1
A14	1124-002-1	NUT-HEX 5/8 (JAM)	2

Ref. No.	Part No.	Part Description	Qty.
A15	1664-009-1	PLUG-PIPE 3/8-18 BRASS DRILLED	2
A16	2310-006-3	SLEEVE-SHAFT SEAL	1
A17	2921-001-1	SCREW-CAP 1/2-13 x 1-1/4	4
A18	4580-001-1	SCREW-DRIVE	6
A19	7400-004-2	HOUSING-MOTOR	1
A20	8206-000-1	PLATE INSTR (DRAIN)	1
A21	8206-001-1	PLATE INSTR (FILL & DRAIN)	1
A22	8354-000-3	RING-RETAINING STATOR	1
A25	10746-000-2	HOUSING-BEARING	1
A26	10756-000-2	PLATE-SEAL	1
A27	10782-001-3	RING-LABYRINTH	1
A28	10898-000-1	CONNECTOR-BUTT	4
A29	10900-004-5	SEAL SENSOR ASSY	1
A30	10901-000-1	PROBE-SEAL FAILURE	1

Ref. No.	Part No.	Part Description	Qty.
A32	11065-002-3	SCREEN 3.81 DIA.	1
A33	11067-000-1	OIL-LUBRICANT	0.25 qt.
A34	13425-083-1	NAMEPLATE-AGENCY APPROVAL	1
A35	13425-034-1	NAMEPLATE	1
A37	19101A017	SCREW-CAP 3/8-16 x 1-1/4	6
A38	19103A043	SCREW-CAP 1/2-13 x 1-1/2	6
A39	6579-002-1	KEY-SQUARE .250 SQ. x 3.88	1
A40	2855-001-1	KEY-SQUARE 3/8	1
C1	3718-005-1	SEAL Carbon Ceramic / Viton®	1
C1	3718-002-1	SEAL Tungsten Carbide / Viton®	Optional
C2	3718-005-1	SEAL Carbon Ceramic / Viton®	1
C2	3718-002-1	SEAL Tungsten Carbide / Viton®	Optional

Note: Amount of oil required will vary between 8 – 10½ gals. depending on stator size, fill to above motor windings.

Wet End Parts List For use with product built with USEM motor.

Item#	Description	S4TX	S8LX	S12LX	S8LAX	Seal Kits
D1	SCREW-CAP	829-009-1 (4)	07597A021 (4)	-	07597A021 (4)	51700-469-7 CERAMIC
D2	WASHER-IMPELLER HOLD	1945-001-3 (1)	1945-001-3 (1)	1945-001-3 (1)	1945-001-3 (1)	51700-471-7 CARBIDE
D3	SCREW-CAP	3879-002-1 (1)	3879-002-1 (1)	3879-002-1 (1)	3879-002-1 (1)	
D4	CASE-VOLUTE	13688-000-2	7394-200-2	25457F200	7394-000-2	
D5	RING-WEAR	13695-000-3	8345-000-2	25458D000	13535-000-3	
D6	RING-CLAMP	-	-	-	13536-000-3	
D7	BELL-SUCTION	-	-	10587-100-2 (1)	-	
D8	STAND-PUMP S12L	-	-	10627-000-5 (1)	-	
D9	SCREW-CAP	-	-	19106A017 (8)	-	
D10	SCREW-CAP SKT HD 1/4-20	-	-	06106A019 (3)	-	
D11	SCREW-CAP SST	-	-	19103A043 (8)	-	

Pump Model & Impeller List

For use with product built with USEM motor.

S4TX

Description	HP	Volt/ Ph	Cord	Trim	ITEM #1 Impeller
1750 RPM					
S4TX7500FC	75	460/3	2-4	13	13532-109-2
S4TX7500GC	75	575/3	2-4	13	13532-109-2
S4TX10000FC	100	460/3	1/0-4	14	13532-105-2
S4TX10000GC	100	575/3	1/0-4	14	13532-105-2
S4TX12500FC	125	460/3	4/0-3	15	13532-101-2
S4TX12500GC	125	575/3	4/0-3	15	13532-101-2

S8LX

Description	HP	Volt/ Ph	Cord	Trim	ITEM #1 Impeller
1750 RPM					
S8LX7500FC	75	460/3	2-4	12.12X11.12	25252D559
S8LX7500GC	75	575/3	2-4	12.12X11.12	25252D559
S8LX10000FC	100	460/3	1/0-4	13.00X12.00	25252D558
S8LX10000GC	100	575/3	1/0-4	13.00X12.00	25252D558
S8LX12500FC	125	460/3	4/0-3	13.75X12.75	25252D556
S8LX12500GC	125	575/3	4/0-3	13.75X12.75	25252D556
S8LX15000FC	150	460/3	4/0-3	15.00X14.00	25252D551
S8LX15000GC	150	575/3	4/0-3	15.00X14.00	25252D551

S8LX (Cont.)

Description	HP	Volt/ Ph	Cord	Trim	ITEM #1 Impeller
1150 RPM					
S8LX3000DB	30	200/3	1/0-4	13.00X12.00	25252D558
S8LX3000EB	30	230/3	2-4	13.00X12.00	25252D558
S8LX3000FB	30	460/3	4-4	13.00X12.00	25252D558
S8LX3000GB	30	575/3	6-4	13.00X12.00	25252D558
S8LX4000DB	40	200/3	1/0-4	14.25X13.25	25252D553
S8LX4000EB	40	230/3	1/0-4	14.25X13.25	25252D553
S8LX4000FB	40	460/3	2-4	14.25X13.25	25252D553
S8LX4000GB	40	575/3	4-4	14.25X13.25	25252D553
S8LX5000FB	50	460/3	2-4	15.00X14.00	25252D551
S8LX5000GB	50	575/3	2-4	15.00X14.00	25252D551
S8LX6000FB	60	460/3	2-4	15	25252D550
S8LX6000GB	60	575/3	2-4	15	25252D550
870 RPM					
S8LX1500DA	15	200/3	2-4	13.38X12.38	25252D557
S8LX1500EA	15	230/3	4-4	13.38X12.38	25252D557
S8LX1500FA	15	460/3	6-4	13.38X12.38	25252D557
S8LX1500GA	15	575/3	10-4	13.38X12.38	25252D557
S8LX2000DA	20	200/3	2-4	14.85X13.85	25252D552
S8LX2000EA	20	230/3	2-4	14.85X13.85	25252D552
S8LX2000FA	20	460/3	6-4	14.85X13.85	25252D552
S8LX2000GA	20	575/3	8-4	14.85X13.85	25252D552
S8LX2500DA	25	200/3	2-4	15	25252D550
S8LX2500EA	25	230/3	2-4	15	25252D550
S8LX2500FA	25	460/3	6-4	15	25252D550
S8LX2500GA	25	575/3	8-4	15	25252D550

Pump Model & Impeller List (Cont.)

S8LAX

Description	HP	Volt/ Ph	Cord	Trim	ITEM #1 Impeller
1750 RPM					
S8LAX7500FC	75	460/3	2-4	13	13532-005-2
S8LAX7500GC	75	575/3	2-4	13	13532-005-2
S8LAX10000FC	100	460/3	1/0-4	14	13532-001-2
S8LAX10000GC	100	575/3	1/0-4	14	13532-001-2
S8LAX12500FC	125	460/3	4/0-3	15	13532-009-2
S8LAX12500GC	125	575/3	4/0-3	15	13532-009-2

S12LX

Description	HP	Volt/ Ph	Cord	Trim	ITEM #1 Impeller
1750 RPM					
S12LX7500FC	75	460/3	2-4	11.00X10.00	25456E562
S12LX7500GC	75	575/3	2-4	11.00X10.00	25456E562
S12LX10000FC	100	460/3	1/0-4	11.50X11.00	25456E563
S12LX10000GC	100	575/3	1/0-4	11.50X11.00	25456E563
S12LX12500FC	125	460/3	4/0-3	12.50X11.00	25456E564
S12LX12500GC	125	575/3	4/0-3	12.50X11.00	25456E564
S12LX15000FC	150	460/3	4/0-3	13.00X12.00	25456E565
S12LX15000GC	150	575/3	4/0-3	13.00X12.00	25456E565

S12LX (Cont.)

Description	HP	Volt/ Ph	Cord	Trim	ITEM #1 Impeller
1150 RPM					
S12LX4000EB	40	230/3	1/0-4	12.31	25456E560
S12LX4000FB	40	460/3	1/0-4	12.31	25456E560
S12LX4000GB	40	575/3	2-4	12.31	25456E560
S12LX5000EB	50	230/3	4-4	12.31	25456E560
S12LX5000FB	50	230/460/3	2-4	13.06	25456E555
S12LX5000GB	50	575/3	2-4	13.06	25456E555
S12LX6000EB	60	230/460/3	2-4	13.63	25456E553
S12LX6000GB	60	575/3	2-4	13.63	25456E553
S12LX7500FB	75	460/3	1/0-4	14	25456E552
S12LX7500GB	75	575/3	2-4	14	25456E552
870 RPM					
S12LX1500DA	15	200/3	2-4	12.25	25456E561
S12LX1500EA	15	230/3	4-4	12.25	25456E561
S12LX1500FA	15	460/3	6-4	12.25	25456E561
S12LX1500GA	15	575/3	10-4	12.25	25456E561
S12LX2000DA	20	200/3	2-4	13	25456E556
S12LX2000EA	20	2320/3	2-4	13	25456E556
S12LX2000FA	20	460/3	6-4	13	25456E556
S12LX2000GA	20	575/3	8-4	13	25456E556
S12LX2500DA	25	200/3	2-4	13.5	25456E554
S12LX2500EA	25	230/3	2-4	13.5	25456E554
S12LX2500FA	25	460/3	6-4	13.5	25456E554
S12LX2500GA	25	575/3	8-4	13.5	25456E554
S12LX3000DA	30	200/3	2-4	14	25456E552
S12LX3000EA	30	230/3	2-4	14	25456E552
S12LX3000FA	30	460/3	4-4	14	25456E552
S12LX3000GA	30	575/3	6-4	14	25456E552

Motor Parts List

For use with product built with USEM motor.

4-Pole 1750 RPM

Item	4-Pole 1750RPM Description	SD1X5000FC 50HP 460/3/1750	SD1X5000GC 50HP 575/3/1750	SD1X6000FC 60HP 460/3/1750	SD1X6000GC 60HP 575/3/1750	SD1X7500FC 75HP 460/3/1750	SD1X7500GC 75HP 575/3/1750	SD1X10000FC 100HP 460/3/1750	SD1X10000GC 100HP 575/3/1750	SD1X12500FC 125HP 460/3/1750	SD1X12500GC 125HP 575/3/1750	SD1X15000FC 150HP 460/3/1750	SD1X15000GC 150HP 575/3/1750
B1	Connector-Split Bolt	2498-007-1(3)	2498-007-1(3)	2498-007-1(3)	2498-007-1(3)	2498-008-1(3)	2498-007-1(3)	2498-008-1(3)	2498-007-1(3)	2498-009-1(3)	2498-008-1(3)	2498-009-1(3)	2498-009-1(3)
B2	Insulator - Split Bolt	8675-000-1(3)	8675-000-1(3)	8675-000-1(3)	8675-000-1(3)	8675-000-1(3)	8675-000-1(3)	8675-000-1(3)	8675-000-1(3)	8675-000-1(3)	8675-000-1(3)	8675-000-1(3)	8675-000-1(3)
B4	Stator	14158-003-1	14158-603-1	14158-003-1	14158-603-1	14158-003-1	14158-603-1	14157-003-1	14157-603-1	14156-003-1	14156-603-1	14156-003-1	14156-603-1
B5	Rotor/Shaft Assembly	14158-014-5	14158-014-5	14158-014-5	14158-014-5	14158-014-5	14158-014-5	14158-014-5	14158-014-5	14156-014-5	14156-014-5	14156-014-5	14156-014-5
B6	Connector-Butt	11667-000-1(3)	11667-000-1(3)	11667-000-1(3)	11667-000-1(3)	11667-000-1(3)	11667-000-1(3)	11668-000-1(3)	11667-000-1(3)	11668-000-1(3)	11668-000-1(3)	11668-000-1(3)	11668-000-1(3)
B7	Box-Connection	11411-004-5	11411-004-5	11411-004-5	11411-004-5	11411-010-5	11411-004-5	11411-010-5	11411-010-5	11411-010-5	11411-010-5	11411-006-5	11411-010-5
B8	Ring-Spacer	---	---	---	---	---	---	---	---	---	---	---	---
B10*	Oil-Parrifinoc	24709110000 (7.75)	24709110000 (7.75)	24709110000 (7.75)	24709110000 (7.75)	24709110000 (7.75)	24709110000 (7.75)	24709110000 (7.75)	24709110000 (7.75)	24709110000 (8)	24709110000 (8)	24709110000 (8)	24709110000 (8)
B11	Cord Cap	11400-087-5	11400-087-5	11400-087-5	11400-087-5	11400-087-5	11400-087-5	11400-088-5	11400-088-5	11400-089-5	11400-089-5	11400-089-5	11400-089-5
B14	Spring-Bearing Adj.	64-005-1(2)	64-005-1(2)	64-005-1(2)	64-005-1(2)	64-005-1(2)	64-005-1(2)	64-005-1(2)	64-005-1(2)	64-005-1(3)	64-005-1(3)	64-005-1(3)	64-005-1(3)

6-Pole 1150 RPM

Item	6-Pole 1150RPM Description	SD2X3000DB 30HP 200/3/1150	SD2X3000EB 30HP 230/3/1150	SD2X3000FB 30HP 460/3/1150	SD2X3000GB 30HP 575/3/1150	SD2X4000DB 40HP 200/3/1150	SD2X4000EB 40HP 230/3/1150	SD2X4000FB 40HP 460/3/1150	SD2X4000GB 40HP 575/3/1150	SD2X5000EB 50HP 230/3/1150	SD2X5000FB 50HP 460/3/1150	SD2X5000GB 50HP 575/3/1150	SD2X6000FB 60HP 460/3/1150
B1	Connector-Split Bolt	2498-008-1(3)	2498-007-1(3)	2498-005-1(3)	---	2498-008-1(3)	2498-008-1(3)	2498-007-1(4)	2498-005-1(3)	2498-009-1(4)	2498-007-1(3)	2498-007-1(3)	2498-007-1(3)
B2	Insulator - Split Bolt	8675-000-1(3)	8675-000-1(3)	8675-002-1(3)	---	8675-000-1(3)	8675-000-1(3)	8675-000-1(4)	8675-000-1(3)	8675-002-1(3)	8675-000-1(3)	8675-000-1(3)	8675-000-1(3)
B3	Connector-Wire	---	2494-000-1(1)	2494-00-1(3)	---	---	---	2494-000-1(3)	---	---	2494-000-1(3)	---	---
B4	Stator	14161-203-1	14161-003-1	14161-003-1	14161-603-1	14161-203-1	14161-003-1	14161-003-1	14161-603-1	14160-003-1	14160-003-1	14160-003-1	14159-003-1
B5	Rotor/Shaft Assembly	14161-014-5	14161-014-5	14161-014-5	14161-014-5	14161-014-5	14161-014-5	14161-014-5	14161-014-5	14160-014-5	14160-014-5	14160-014-5	14159-014-5
B6	Connector-Butt	11668-000-1(3)	8790-000-1(9)	8790-000-1(9)	23394A001(3)	11668-000-1(3)	11667-000-1(9)	8790-000-1(9)	23394A001(3)	11667-000-1(9)	8790-000-1(9)	23394A001(3)	8790-000-1(3)
B7	Box-Connection	11411-010-5	11411-005-5	11411-005-5	11411-002-5	11411-010-5	11411-010-5	11411-003-5	11411-010-5	11411-010-5	11411-005-5	11411-002-5	11411-004-5
B8	Ring-Spacer	8662-010-1	8662-010-1	8662-010-1	8662-010-1	8662-010-1	8662-010-1	8662-010-1	8662-010-1	8662-007-1	8662-007-1	8662-007-1	---
B10*	Oil-Parrifinoc	24709110000 (10)	24709110000 (10)	24709110000 (10)	24709110000 (10)	24709110000 (10)	24709110000 (10)	24709110000 (10)	24709110000 (10)	24709110000 (8)	24709110000 (8)	24709110000 (8)	24709110000 (7.75)
B11	Cord Cap	11400-088-5	11400-087-5	11400-086-5	11400-085-5	11400-088-5	11400-088-5	11400-087-5	11400-086-5	11400-089-5	11400-087-5	11400-087-5	11400-087-5
B14	Spring-Bearing Adj.	64-005-1(2)	64-005-1(2)	64-005-1(2)	64-005-1(2)	64-005-1(2)	64-005-1(2)	64-005-1(2)	64-005-1(2)	64-005-1(2)	64-005-1(2)	64-005-1(2)	64-005-1(2)

*Fill Oil to above the Motor Windings

Motor Parts List (Cont.)

6-Pole 1150 RPM (Cont.)

Item	6-Pole 1150RPM Description	SD1X6000GB	SD1X7500FB	SD1X7500GB
		60HP 575/3/1150	75HP 460/3/1150	75HP 575/3/1150
B1	Connector-Split Bolt	2498-007-1(3)	2498-008-1(3)	2498-007-1(3)
B2	Insulator - Split Bolt	8675-000-1(3)	8675-000-1(3)	8675-000-1(3)
B3	Connector-Wire	---	---	---
B4	Stator	14159-603-1	14159-003-1	14159-603-1
B5	Rotor/Shaft Assembly	14159-014-5	14159-014-5	14159-014-5
B6	Connector-Butt	11667-000-1(3)	11667-000-1(3)	11667-000-1(3)
B7	Box-Connection	11411-004-5	11411-010-5	11411-004-5
B8	Ring-Spacer	---	---	---
B10*	Oil-Parrifinic	24709110000 (7.75)	24709110000 (7.75)	24709110000 (7.75)
B11	Cord Cap	11400-087-5	11400-088-5	11400-087-5
B14	Spring-Bearing Adj.	64-005-1(2)	64-005-1(2)	64-005-1(2)

8-Pole 750 RPM

Item	8-Pole 870RPM Description	SD1X1500DA	SD1X1500EA	SD1X1500FA	SD1X1500GA	SD1X2000DA	SD1X2000EA	SD1X2000FA	SD1X2000GA	SD1X2500DA	SD1X2500EA	SD1X2500FA	SD1X2500GA
		15HP 200/3/870	15HP 230/3/870	15HP 460/3/870	15HP 575/3/870	20HP 200/3/870	20HP 230/3/870	20HP 460/3/870	20HP 575/3/870	25HP 200/3/870	25HP 230/3/870	25HP 460/3/870	25HP 575/3/870
B1	Connector-Split Bolt	2498-007-1(3)	2498-005-1(3)	---	---	2498-007-1(3)	2498-007-1(3)	---	---	2498-007-1(3)	2498-007-1(3)	---	---
B2	Insulator - Split Bolt	8675-000-1(3)	8675-002-1(3)	---	---	8675-000-1(3)	8675-000-1(3)	---	---	8675-000-1(3)	8675-000-1(3)	---	---
B3	Connector-Wire	---	2494-000-1(1)	2494-000-1(6)	2494-000-1(3)	---	2494-000-1(1)	2494-000-1(6)	2494-000-1(3)	---	2494-000-1(1)	2494-000-1(6)	2494-000-1(3)
B4	Stator	14163-203-1	14163-003-1	14163-003-1	14163-603-1	14163-203-1	14163-003-1	14163-003-1	14163-003-1	14163-603-1	14162-203-1	14162-003-1	14162-603-1
B5	Rotor/Shaft Assembly	14163-014-5	14163-014-5	14163-014-5	14163-014-5	14163-014-5	14163-014-5	14163-014-5	14163-014-5	14163-014-5	14162-014-5	14162-014-5	14162-014-5
B6	Connector-Butt	8790-000-1(3)	1006-001-1(9)	23394A003(9)	23394A003(3)	8790-000-1(3)	1006-001-1(9)	23394A003(9)	23394A003(3)	8790-000-1(3)	23394A003(9)	11666-000-1(9)	23394A003(3)
B7	Box-Connection	11411-002-5	11411-003-5	11411-001-5	11411-000-5	11411-002-5	11411-003-5	11411-001-5	11411-000-5	11411-004-5	11411-005-5	11411-001-5	11411-000-5
B8	Ring-Spacer	8662-009-1	8662-009-1	8662-009-1	8662-009-1	8662-009-1	8662-009-1	8662-009-1	8662-009-1	8662-002-1	8662-002-1	8662-002-1	8662-002-1
B10*	Oil-Parrifinic	24709110000(8)	24709110000(8)	24709110000(8)	24709110000(8)	24709110000(8)	24709110000(8)	24709110000(8)	24709110000(8)	24709110000(8)	24709110000(8)	24709110000(8)	24709110000(8)
B11	Cord Cap	11400-087-5	11400-086-5	11400-085-5	11400-083-5	11400-087-5	11400-087-5	11400-085-5	11400-084-5	11400-087-5	11400-087-5	11400-085-5	11400-084-5
B14	Spring-Bearing Adj.	64-005-1(2)	64-005-1(2)	64-005-1(2)	64-005-1(2)	64-005-1(2)	64-005-1(2)	64-005-1(2)	64-005-1(2)	64-005-1(2)	64-005-1(2)	64-005-1(2)	64-005-1(2)

Item	8-Pole 870RPM Description	SD1X3000DA	SD1X3000EA	SD1X3000FA	SD1X3000GA
		25HP 200/3/870	25HP 230/3/870	25HP 460/3/870	25HP 575/3/870
B1	Connector-Split Bolt	2498-007-1(3)	2498-007-1(3)	---	---
B2	Insulator - Split Bolt	8675-000-1(3)	8675-000-1(3)	---	---
B3	Connector-Wire	---	2494-000-1(1)	2494-000-1(6)	2494-000-1(3)
B4	Stator	14162-203-1	14162-003-1	14162-003-1	14162-603-1
B5	Rotor/Shaft Assembly	14162-014-5	14162-014-5	14162-014-5	14162-014-5
B6	Connector-Butt	11667-000-1(3)	23394A002(9)	11666-000-1(9)	23394A003(3)
B7	Box-Connection	11411-010-5	11411-005-5	11411-001-5	11411-000-5
B8	Ring-Spacer	8662-002-1	8662-002-1	8662-002-1	8662-002-1
B10*	Oil-Parrifinic	24709110000(8)	24709110000(8)	24709110000(8)	24709110000(8)
B11	Cord Cap	11400-087-5	11400-087-5	11400-086-5	11400-085-5
B14	Spring-Bearing Adj.	64-005-1(2)	64-005-1(2)	64-005-1(2)	64-005-1(2)

*Fill Oil to above the Motor Windings

STANDARD LIMITED WARRANTY

HYDROMATIC® warrants its products against defects in material and workmanship for a period of 12 months from the date of shipment from Hydromatic or 18 months from the manufacturing date, whichever occurs first - provided that such products are used in compliance with the requirements of the Hydromatic catalog and technical manuals for use in pumping raw sewage, municipal wastewater or similar, abrasive free non-corrosive liquids.

During the warranty period and subject to the conditions set forth, Hydromatic, at its discretion, will repair or replace to the original user, the parts which prove defective in materials and workmanship. Hydromatic reserves the right to change or improve its products or any portions thereof without being obligated to provide such a change or improvement for prior sold and/or shipped units.

Start-up reports and electrical schematics may be required to support warranty claims. Warranty is effective only if Hydromatic authorized control panels are used. All seal fail and heat sensing devices must be hooked up, functional and monitored or this warranty will be void. Hydromatic will only cover the lower seal and labor thereof for all dual seal pumps. Under no circumstance will Hydromatic be responsible for the cost of field labor, travel expenses, rented equipment, removal/reinstallation costs or freight expenses to and from the factory or an authorized Hydromatic service facility.

This limited warranty will not apply: (a) to defects or malfunctions resulting from failure to properly install, operate or maintain the unit in accordance with the printed instructions provided; (b) to failures resulting from abuse, accident or negligence; (c) to normal maintenance services and parts used in connection with such service; (d) to units which are not installed in accordance with applicable local codes, ordinances and good trade practices; (e) if the unit is moved from its original installation location; (f) if unit is used for purposes other than for what it is designed and manufactured; (g) to any unit which has been repaired or altered by anyone other than Hydromatic or an authorized Hydromatic service provider; (h) to any unit which has been repaired using non factory specified/OEM parts.

Warranty Exclusions: HYDROMATIC MAKES NO EXPRESS OR IMPLIED WARRANTIES WHICH EXTEND BEYOND THE DESCRIPTION ON THE FACE HEREOF. HYDROMATIC SPECIFICALLY DISCLAIMS THE IMPLIED WARRANTIES OF MERCHANTABILITY AND FITNESS FOR ANY PARTICULAR PURPOSE.

Liability Limitation: IN NO EVENT SHALL HYDROMATIC BE LIABLE OR RESPONSIBLE FOR CONSEQUENTIAL, INCIDENTAL OR SPECIAL DAMAGES RESULTING FROM OR RELATED IN ANY MANNER TO ANY HYDROMATIC PRODUCT OR PARTS THEREOF. PERSONAL INJURY AND/OR PROPERTY DAMAGE MAY RESULT FROM IMPROPER INSTALLATION. HYDROMATIC DISCLAIMS ALL LIABILITY, INCLUDING LIABILITY UNDER THIS WARRANTY, FOR IMPROPER INSTALLATION. HYDROMATIC RECOMMENDS INSTALLATION BY PROFESSIONALS.

Some states do not permit some or all of the above warranty limitations or the exclusion or limitation of incidental or consequential damages and therefore such limitations may not apply to you. No warranties or representations at any time made by any representatives of Hydromatic shall vary or expand the provision hereof.



**Pentair
Water™**

USA

740 East 9th Street, Ashland, Ohio 44805
Tel: 419-289-3042 Fax: 419-281-4087

www.hydraulic.com

– Your Authorized Local Distributor –

CANADA

269 Trillium Drive, Kitchener, Ontario, Canada N2G 4W5
Tel: 519-896-2163 Fax: 519-896-6337

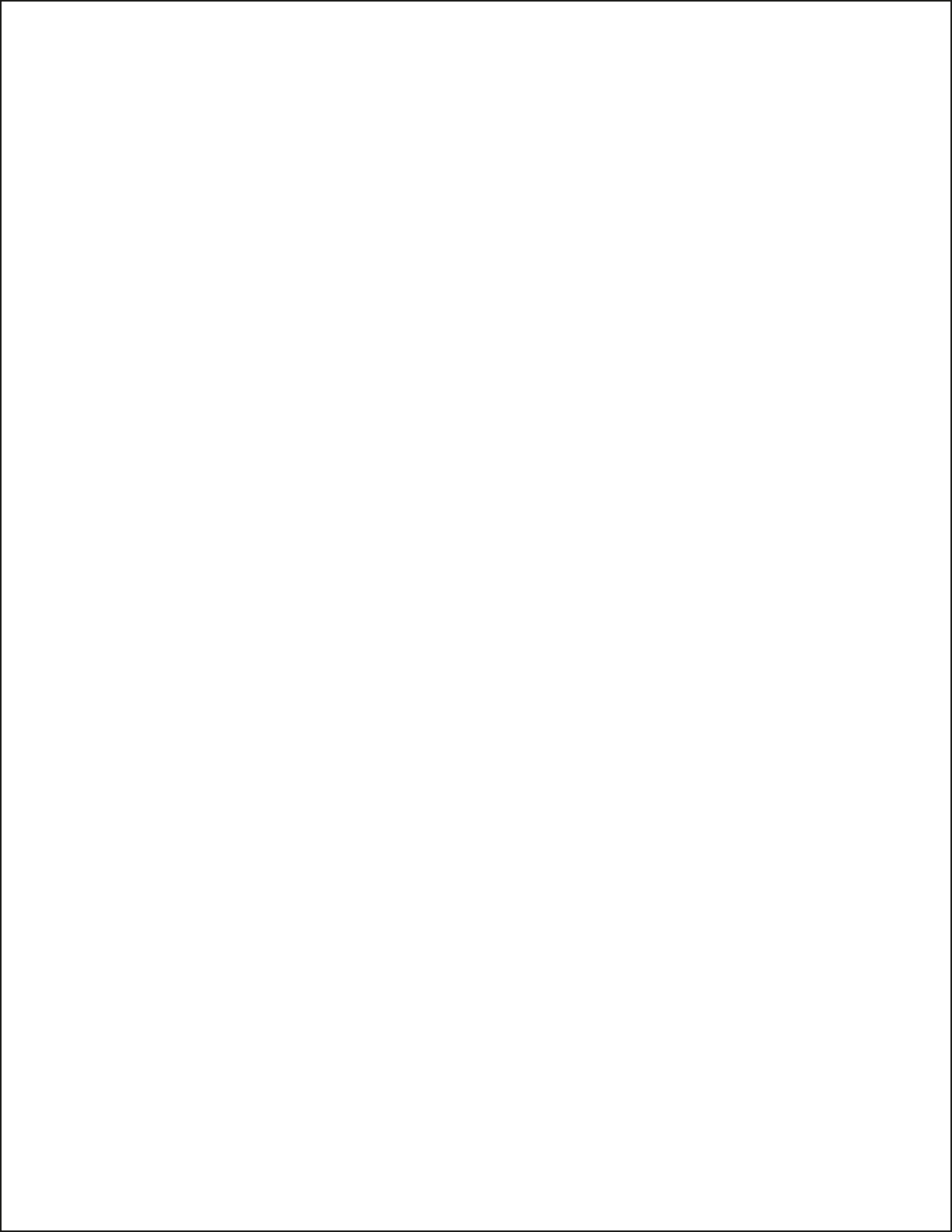

Distributor: _____ Order No.: _____
Installing Contractor: _____ Phone: _____
Sales Contact: _____ Phone: _____
Customer: _____
Location: _____

1. SYSTEM INFORMATION

Size of Wet Well: _____ Manufacturer: _____
Discharge from Bottom of Basin: _____ Discharge Location: _____
Inlet from Bottom of Basin: _____ Inlet Location: _____
Type of Check Valves: _____ Type of Piping: _____
Does System Have Suction Gauges? Yes No Suction Pressure Reading: _____
Does System Have Discharge Gauges? Yes No Discharge Pressure Reading: _____
Liquid Being Pumped: _____ Temperature (F°): _____ Pct. of Solid (%): _____
Is a Sketch or Photograph of System Available? Yes No *If So, Please Attach.*
Any Additional Comments on System: _____

2. ELECTRICAL INFORMATION

Control Panel Part Number: _____ Panel Rated Amps: _____
Manufacturer: _____ Voltage: _____ Phase: _____
Heater Size: _____ Location of Panel to Wet Well: _____
Incoming Line Voltage: _____ Actual? _____
Voltage to Pumps: _____ Actual? _____
Type of Junction Box: _____ Manufacturer of Junction Box: _____
Are Floats Installed in Wet Well? Yes No Are Floats Set to Engineer's Specs? Yes No
Are Floats Wired for Proper Sequencing? Yes No Are Heat Sensors Hooked Up? Yes No
Is the Seal Leak Detection Hooked Up? Yes No
Any Additional Comments on Electrical: _____

3. PUMP INFORMATION

Type of Pump: _____ Serial Number of Pump: _____
Voltage of Pump: _____ Phase: _____ RPM: _____ Amps: _____
Impeller Size: _____ C.O.S. TDH: _____ GPM: _____
Voltage Supplied from Panel: _____ Actual? _____
Actual Amperage (All Phases): Phase 1 Amps: _____ Phase 2 Amps: _____ Phase 3 Amps: _____
Define the Rotation of the Pump: Clockwise Counterclockwise
Method Used to Check Rotation: Viewed from the Top Viewed from the Bottom
Any Additional Comments on Pumps: _____

4. ACKNOWLEDGE

Acknowledge that all information is accurate and proper procedures have been followed.
Customer: _____ Date: _____
Start-up Technician: _____ Date: _____

Send to Warranty Manager, 1101 Myers Parkway, Ashland, OH 44805
or Fax to 419-207-3344
or email to startupreport@hydromatic.com
or submit online at <http://forms.pentairliterature.com/startupform/startupform.asp?type=h>