

Installation and Service Manual

VORTEX SEWAGE PUMP

Model S4NRC



NOTE! To the installer: Please make sure you provide this manual to the owner of the pumping equipment or to the responsible party who maintains the system.

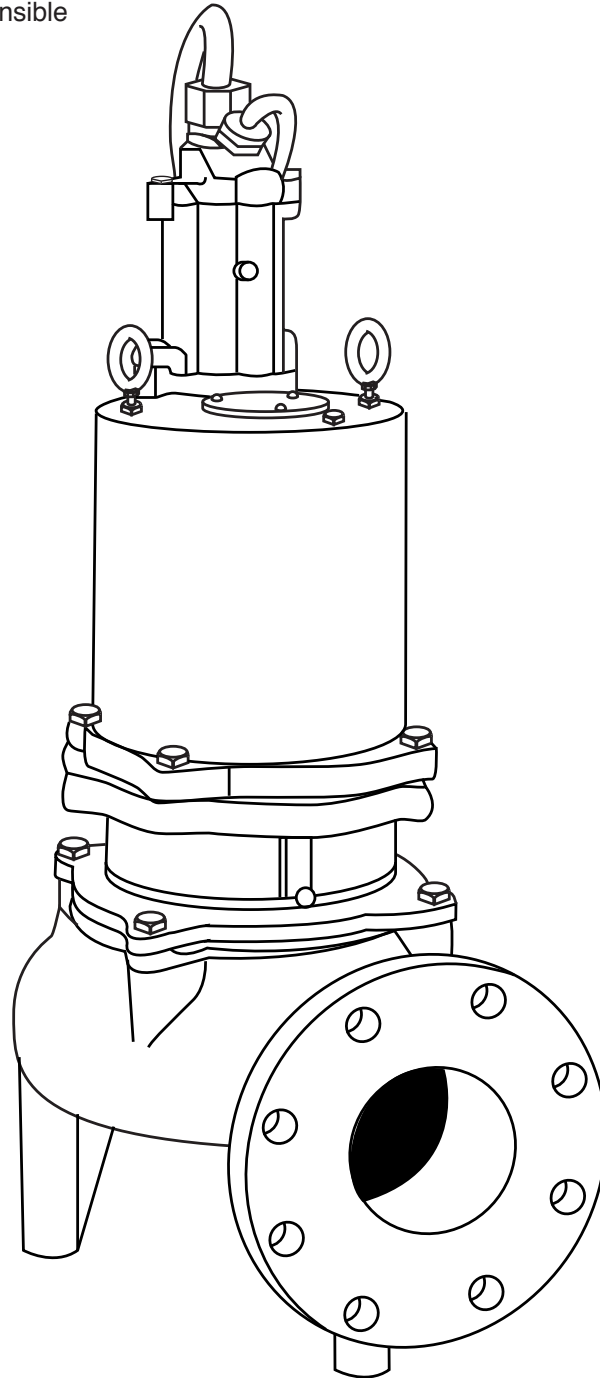

HYDROMATIC[®]
Pentair Water

03/11
Item # E-03-313
Part # 5625-313-1
© 2011 Pentair Pump Group, Inc.

General Information

Thank you for purchasing your Hydromatic® pump. To help ensure years of trouble-free operation, please read the following manual carefully.

Before Operation:

Read the following instructions carefully. Reasonable care and safe methods should be practiced. Check local codes and requirements before installation.

ATTENTION: This manual contains important information for the safe use of this product. Read this manual completely before using this product and refer to it often for continued safe product use. DO NOT THROW AWAY OR LOSE THIS MANUAL. Keep it in a safe place so that you may refer to it often.

WARNING: Before handling these pumps and controls, always disconnect the power first. Do not smoke or use sparkable electrical devices or flames in a septic (gaseous) or possible septic sump.

Shipping:

When unpacking unit check for concealed damage. CLAIM FOR DAMAGE MUST BE MADE AT THE RECEIVING END THROUGH THE DELIVERING CARRIER. DAMAGE CANNOT BE PROCESSED FROM THE FACTORY.

Pumps Not Operating or in Storage:

Pumps with carbon ceramic seals must have impellers manually rotated (6 revolutions) after setting non-operational for 3 months or longer and prior to electrical start-up.

Pumps with tungsten carbide seals must have impellers manually rotated (6 revolutions) after setting non-operational for 3 weeks or longer and prior to electrical start-up.

Seal Failure:

An electrode is installed in the seal chamber so if any water enters the chamber through the first seal the electrode will be energized and a signal will be transmitted to the sensing unit at ground surface causing a red light to turn on. The electrode probe is installed in all units but the sensing unit is supplied at extra cost and must be ordered.

In operation the seal failure unit indicates only that there is some water in the seal chamber. The pump will continue to operate without damage but the seal should be checked within 30 days after failure is indicated.

The sensing unit is recommended on all installations as good insurance against motor failure.

Pump:

The S4NRC submersible pump is supplied for 1 and 3 phase and for 200, 230, 460 or 575 volts. Pump is supplied with 30 feet of power cord and/or 30 feet of auxiliary control cord. Longer cable lengths can be furnished but must be specified at time of order. Power cable is 4 wire with the green wire for ground. Be sure green wire is connected to a good ground such

as water pipe or ground stake. The auxiliary cable for seal failure and heat sensors is also 4 wire color coded.

Heat Sensors:

All motors have heat sensor units embedded in the motor winding to detect excessive heat. The heat sensors are set to trip at 120°C on the S4NRC. The sensors automatically reset when motor cools to safe temperature.

The sensors are connected in series with the motor starter coil so that the starter is tripped if heat sensor opens. The motor starter is equipped with overload heaters so all normal overloads are protected by the starter.

IMPORTANT: If Hydromatic electrical starting equipment is not supplied the heat sensor circuit must be connected in series with the starter coil or warranty on motor is void. Connection diagram is included in this manual.

Sump Level Control:

Sump level is controlled by Hydromatic switch controls. The float is held in position in the sump by weight attached to the power cord above the float. The cord supports the float and is adjusted for height from the surface.

Duplex systems use three controls: one set at turn-off, one set at turn-on for one pump, and one set for turn-on for two pumps. Pumps alternate operation on each successive cycle.

Two pumps operate together only if sump level rises to the third or override control. The override control also brings on the second pump in case of failure of the first

pump. Extra floats with appropriate controls can be supplied for alarm functions. Triplex systems use four controls: one set at turn-off, one set at turn-on for one pump, one set at turn-on for two pumps, and one set at turn-on for three pumps. Pumps alternate each successive cycle.

Three pumps operate together only if sump level rises to the fourth control (second override). This control also brings on the third pump in case of failure of either or both of the first two pumps.

Alarm Controls:

The alarm level is usually set above the override level so the alarm will signal only if the override level is exceeded. However, some engineers prefer to have the alarm level set below the override level as it is possible for one pump to fail and the other pump to operate on the override level with the sump level never reaching the alarm level. This is particularly true in cases of low inflow capacity.

Electrical Control Panel:

It is recommended that the Hydromatic control panel be used

with all pumps as proper starter heaters and connections for heat sensor wires are furnished.

IMPORTANT: If Hydromatic electrical controls are not used and the motor fails because of improper components or if the heat sensors are not properly connected, the motor guarantee is void.

Hydromatic electrical equipment is installed in a weatherproof NEMA 3R enclosure. The electrical equipment includes a main circuit breaker for each pump, a magnetic starter with overload protection for each

**WIRE SIZE TABLE
FOR REMOTE LOCATION OF CONTROL PANEL
LENGTHS ARE BASED ON A VOLTAGE DROP OF TWO PERCENT**

Maximum length in feet from NEMA 4 Junction Box to control panel. All control wires can be = 14-16 or 18 gauge wire. If power lines are greater than 300 volts, and the control wires are used in the same conduit, then the insulation of the control wires must be for 600 volts.

Wire Size	1 Phase					3 Phase							
	Volts	HP				Volts	HP						
		1½	2	3	5		1½	2	3	5	7½	10	15
12	200V	-	-	-	-	200	217	190	101	-	-	-	-
	230	105	95	-	-	230	291	250	134	-	-	-	-
						460	1165	1019	540	412	333	233	-
						575	1820	1450	820	624	515	364	-
						200	340	297	158	119	-	-	-
10	200	121	111	103	-	200	340	297	158	119	-	-	-
	230	163	148	139	-	230	456	390	210	161	-	-	-
						460	1822	1594	846	645	522	364	-
						575	2847	2270	1360	976	806	569	-
						200	533	466	249	187	155	-	-
8	200	190	175	162	-	200	533	466	249	187	155	-	-
	230	257	232	219	-	230	715	613	330	252	204	-	-
						460	2860	2500	1328	1013	819	572	390
						575	4468	3570	2145	1532	1266	894	-
						200	830	726	387	291	242	170	-
6	200	296	272	252	-	200	830	726	387	291	242	170	-
	230	400	362	340	181	230	1114	955	514	393	318	223	-
						460	4455	3898	2068	1577	1275	891	607
						575	-	-	3341	2386	1972	1392	-
						200	1268	1110	592	444	370	260	-
4	200	452	416	384	-	200	1268	1110	592	444	370	260	-
	230	610	553	520	276	230	1701	1458	785	601	486	340	232
						460	-	-	3160	2410	1449	1361	928
						575	-	-	-	3646	2513	2127	-
						200	1932	1690	902	676	563	395	-
*2	200	689	633	586	-	200	1932	1690	902	676	563	395	-
	230	930	842	792	421	230	2592	2222	1196	915	741	578	353
						460	-	-	-	3672	2969	2074	1414
						575	-	-	-	-	4590	3240	-

*Special junction box required for wire sizes larger than #4.

**NUMBER OF CONDUCTORS REQUIRED BETWEEN CONTROL PANEL AND NEMA 4 JUNCTION BOX
POWER LINES AND CONTROL WIRES CAN BE CARRIED IN CONDUIT OR CAN BE UNDERGROUND BURIED CABLE**

System Type	Number of Control Wires	Number of Power Lines	Number of Ground Wires #8	HEAT SENSOR & SEAL FAILURE	
				Number of Sensor Wires	Number of Ground Wires
Simplex	4	3	1	3	1
Simplex with Alarm	6	3	1	3	1
Duplex	6	6	2	6	2
Duplex with Alarm	8	6	2	6	2

General Information

pump, an H-O-A switch and run light for each pump, an electric alternator and a transformer to provide appropriate control for control circuit and alarms.

Overload Heaters:

Starters with 3 leg overload protection must be supplied if the Hydromatic electrical panel is not used. The heaters must be sized in accordance with the nameplate amps on the motor. The amp draw on these submersible motors is slightly higher than a corresponding horsepower surface motor, so heaters must be sized by the nameplate rating.

IMPORTANT: Make certain the heat sensor wires are connected in series with the starter coil circuit if other than Hydromatic starters are used. Typical wiring diagrams are included.

Pump Installation

Unpacking Pump:

Remove pump from carton. When unpacking unit, check for

concealed damage. Claims for damage must be made at the receiving end through the delivery carrier. Damage cannot be processed from the factory.

Installing Pump in Sump:

Before installing pump in sump, lay it on side and turn impeller with fingers. Impeller may be slightly stuck due to factory test water, so it must be broken loose with small bar or screwdriver in edge of vanes. The impeller should turn freely.

Clean all trash and sticks from sump and connect pump to piping.

A check valve must be installed on each pump. A gate or plug valve in each pump discharge line is also recommended. This valve should be installed on the discharge side of the check valve so the line pressure can be cut off if necessary to service the check valve. Single pump systems are sometimes installed without a check valve where it is desirable to self-drain the discharge line to prevent freezing. This can be done only with short discharge lines. Otherwise water will return to the sump and cause short cycling of the pump.

NEMA 4 Junction Box (Optional):

A NEMA 4 junction box should be used to make power and control connections if electrical

control panel is to be set remote from the pump sump. The Hydromatic Nema 4 junction box is provided with compression connectors for sealing all wires. No sealing compound is needed to make connections waterproof.

Wiring diagrams are provided with the panel for making connections. An extra set of diagrams is included so that one set can be used in the sump when making connections. The size wire to use from panel to sump depends on motor size and distance in feet.

The wire size table on Page 3 can be used as a guide for wire size. Be sure each wire is checked out so that a wrong connection will not be made. An ohmmeter or Megger can be used to check wire continuity. Attach one side of meter to ground and other side to one side at control panel. Then have person in sump touch one wire to ground. If wire is correct, meter will show reading. A Walkie-Talkie radio is useful if some distance exists between sump and panel.

Installing Switch Controls:

The controls are supported by a mounting bracket that is attached to sump wall, cover, or to the NEMA 4 junction box.

Cord snubbers are used to hold the cord in place. Control level

Fig. 1

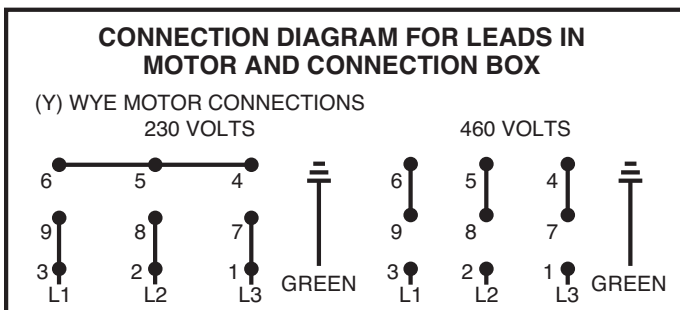
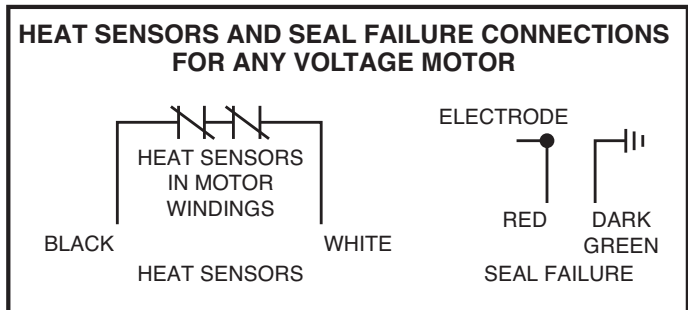

Fig. 2



can be changed at any time by loosening the snubber and readjusting cord length.

In either a simplex or duplex system, the lower or turn-off control is set just above the top of volute, so that the volute will always be submerged during the pumping cycle. The second, or turn-on control, is set about 24 inches above the lower turn-off control.

More distance between turn-on and turn-off controls can be used, but sewage may become septic, and excessive solids may collect for the pump to handle. A frequent pumping cycle is recommended for best operation.

If an alarm system is used, this control is usually set about 6 inches above the override control.

Some engineers, as described previously, prefer to have the alarm control set below the override control.

Making Electrical Connections:

All electrical wiring must be in accordance with local codes, and only competent electricians should make the installations. Complete wiring diagrams are glued to the inside cover of the panel, and an additional set of prints is included for use in making the installation. All wires should be checked for grounds with an ohmmeter or Megger after the connections are made. This is important, as one grounded wire can cause considerable trouble. (See Figure 1.)

IMPORTANT: If equipment is not properly wired and protected as recommended, the motor guarantee is void.

Heat Sensors and Seal Failure Connections:

Be sure heat sensor wires are connected in series with the starter coil. Connections are provided on the terminal strip (see wiring diagram).

If seal failure unit is used, connect as shown with seal failure system. If seal failure unit is not used, the two seal failure wires are left open.

DO NOT CONNECT POWER TO THESE LINES AT ANY TIME. (See Figures 2 and 3.)

Fig. 3

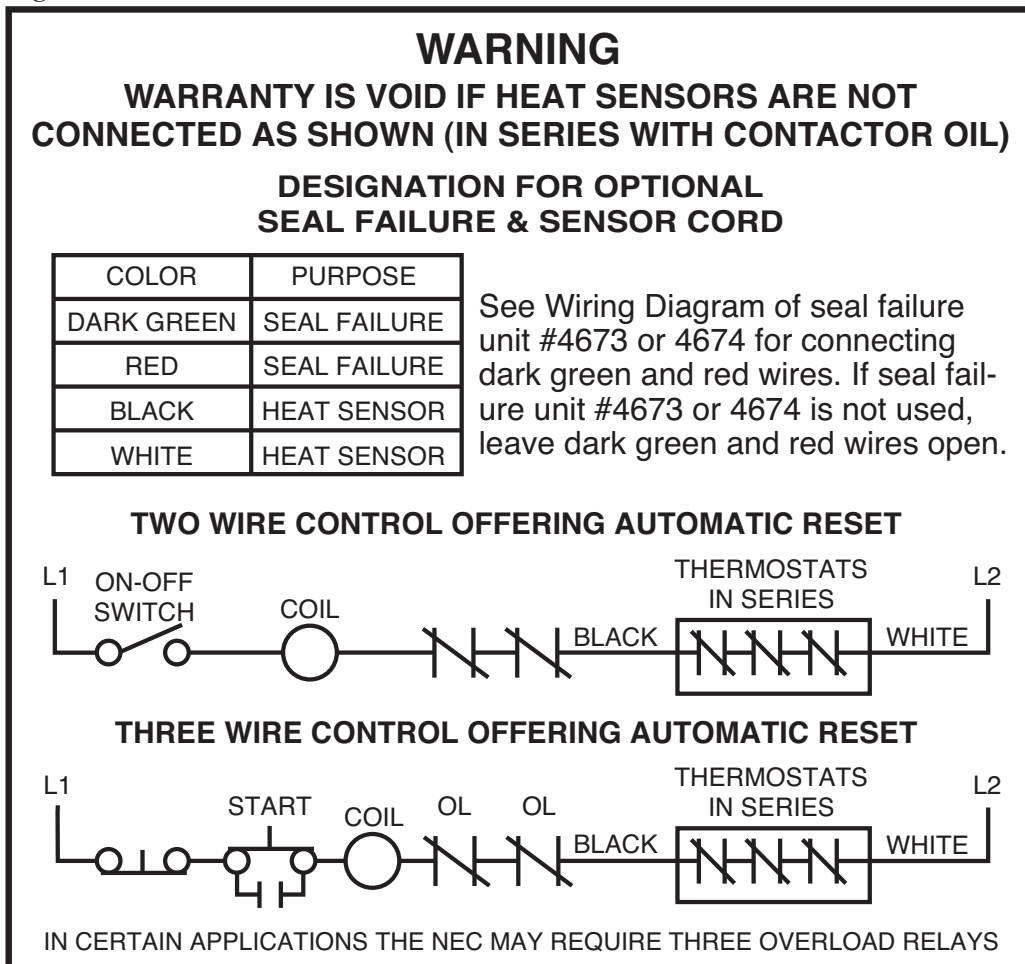

Pump Operations

Starting System:

1. Turn H-O-A switch to Off position and then turn on main circuit breakers.
2. Open all discharge valves and allow water to rise in sump.
3. Turn H-O-A switch to Hand position on one pump and notice operation. If pump is noisy and vibrates, rotation is wrong. To change rotation, interchange any two line leads to motor 3 ϕ only. Do not interchange main incoming lines. If duplex system, check second pump in same manner.
4. Now set both H-O-A switches to Auto position and allow water to rise in sump until one pump starts. Allow pump to operate until the level drops to turn-off point.
5. Allow sump level to rise to start other pump. Notice run lights on panel. Pumps should alternate on each successive cycle of operation.
6. Turn both H-O-A switches to Off position and allow sump to fill to the override control level.
7. Turn both switches to Auto position and both pumps should start and operate together until level drops to turn-off point.
8. Repeat this operation cycle several times before leaving the job.
9. Check voltage when pumps are operating and check the amp draw of each pump. Check amps on each wire, as sometimes a high leg will exist. One leg can be

somewhat higher (5 to 10%) without causing trouble. For excessive amp draw on one leg, the power company should be consulted.

Phase Converters:

Phase converters are generally not recommended, but in cases where only single phase current is available, phase converters can be

used. Be sure to size the phase converter large enough for the amp draw specified on the motor nameplate, not necessarily by motor horsepower. The warranty on all three phase submersible motors is void if operated with single phase power through a phase converter, and 3 leg ambient compensated extra-quick trip overload protectors are not used.

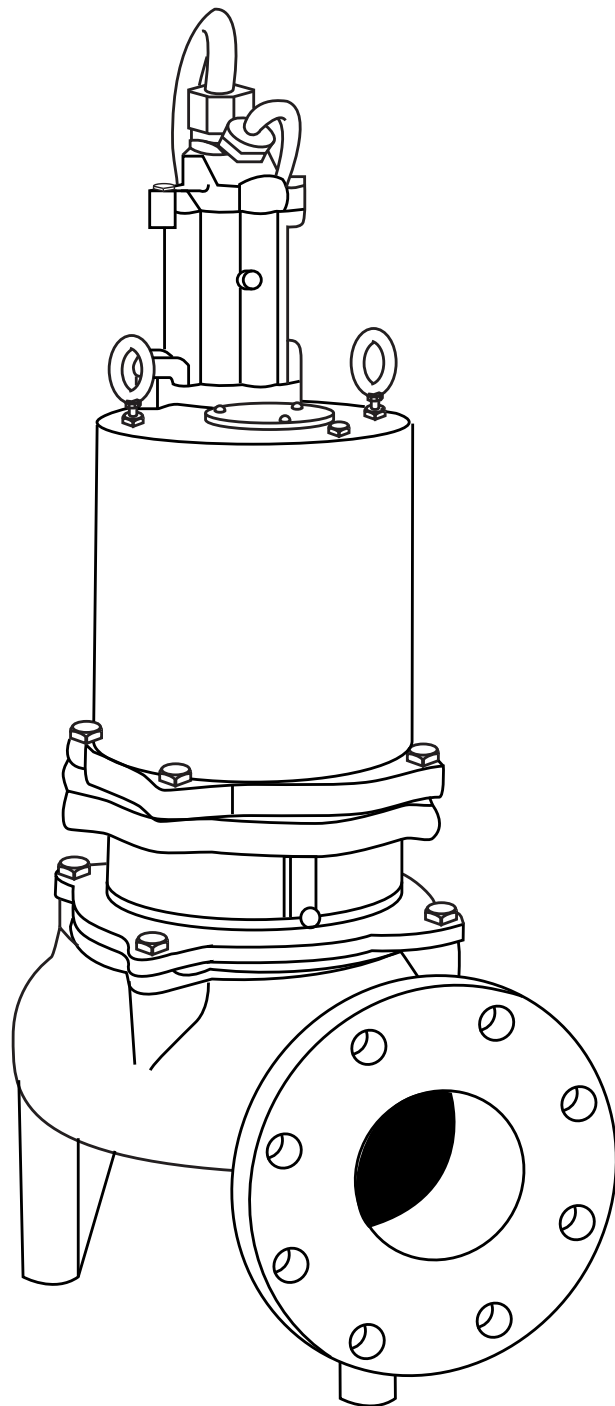

Pump Maintenance

Lubrication or other maintenance is not required, as the motors are oil filled.

If a seal failure unit is used, no attention is necessary as long as the seal shows satisfactory operation.

If seal failure is not used, the pump should be lifted once every two years and the oil drained from the seal chamber to check for water.

Generally, these pumps give very reliable service, and can be expected to operate for many years without failure under normal operating conditions.

Lightning:

In some areas where considerable lightning occurs, it is recommended that a lightning arrestor be installed at the control panel. Lightning arrestors are good insurance against damage to an expensive motor.

Servicing Instructions:

IMPORTANT: Read all instructions before replacing any parts.

WARNING: Before handling these pumps and controls, always disconnect the power first. Do not smoke or use sparkable electrical devices or flames in a septic (gaseous) or possible septic sump.

Field Service on Motor

All S4NRC submersible motors can be serviced (out of warranty)

in the field by any reliable motor service shop. Any pump (in warranty) must be returned for service or repaired in an authorized Hydromatic service shop. Charges will not be allowed if (in warranty) pump is taken to a motor repair shop that is not authorized.

When field service is performed on a pump, these instructions should be carefully followed.

Replacing Stator:

If motor winding is burned or shortened it can be rewound or replaced with new factory wound stator. Refer to sectional drawing of pump and motor and use the following steps to remove and replace stator.

1. If stator only is damaged it may not be necessary to completely dismantle pump as stator and housing can be lifted from pump without disturbing seals or bearings.
2. Drain all oil from upper housing, remove from upper housing, remove drain plug in bottom of stator housing and remove plug in top of housing to allow air to enter.
3. After chamber is drained, remove hold-down bolts and lift off. Use care in lifting as the seal failure connecting wire must be disconnected before housing is completely removed. See sectional drawing.
4. Set assembly on bench and remove connection box. When box is lifted off, connection wires to motor will be exposed. These wires will probably be burned, but each wire is tagged with a metal marker giving wire number. Cut the wires.

If the leads to the connection box are burned, a complete new connection box with new wire must be used. The wires are potted in with sealing compound and a new unit must be obtained from the factory.

5. The stator is held in the housing with a bolted-in clamp ring.
6. After ring is removed, turn housing upright and bump on hardwood blocks. This should jar the stator loose and allow it to drop out.
7. Thoroughly clean housing before replacing new stator. Replace stator and make all wire connections to the connection box before replacing housing on pump. This is important as leads must be tucked behind the windings by using hands up through rotor core.

IMPORTANT: Use only compression type insulated connectors on the wires. Do not tape leads as oil will deteriorate the tape and cause damage to stator and bearings.

8. Drain oil from chamber. If oil is clean and no water is present, seals can be considered satisfactory to reuse.
9. Check top bearing. If clean and does not turn rough, bearings can be reused and it is not necessary to completely dismantle pump to change bearings. If bearings are damaged with dirt or heat, they must be replaced. See additional instructions on

replacing seals and bearings (Page 8). Remember to reinstall the upper bearing load spring.

10. Replace stator housing onto seal chamber and bolt in place. **BE SURE SEAL FAILURE WIRE IS CONNECTED BEFORE HOUSING IS ASSEMBLED.**

Be sure O-ring seal has been replaced. If O-ring is nicked or cut, replace with new rings. This applies to all O-rings used in assembly.

11. After all leads are reconnected in the connection box, make a high voltage ground test on each wire. The only wire that should show ground is the green power lead and the ground lead in the auxiliary control cable.

12. For safety, complete pump should be air checked under water for leaks. If seals were OK, refill seal chamber with oil. Lay pump on side for this oil filling with oil fill hole upright. Do not completely fill; leave oil about 1 inch below plug hole. Use only #10 non-detergent automobile oil or regular Hydromatic submersible oil in this chamber. Replace plug; use Permatex on threads. Install air valve in top plug opening of motor housing and charge housing with about 10 psi of air. Be sure air is dry. Do not use air line where water may be trapped in the line. Submerge complete unit under water and check for leaks.

13. Refill motor chamber with oil. Use high grade transformer oil or Hydromatic special submersible oil. Fill chamber until oil covers top of

windings. Leave air space in top for expansion. Use Permatex on plug threads.

Replacing Seals and Bearings:

1. Drain all oil from motor chamber and seal chamber as described.

2. Remove motor housing as described.

3. Remove bolts that hold seal chamber to pump housing. Use back-off screws to break loose. With hardwood block, tape end of impeller to loosen from shaft. When free, remove impeller from shaft.

4. Lift rotating assembly (rotor, shaft and impeller) from pump case and place horizontally on bench.

5. Impeller removal— S4NRC

Hold motor and remove bolt and washer from impeller end of shaft. Impeller is threaded to the shaft, so tap face of impeller with hardwood block to free threads. Holding rotor, turn impeller counterclockwise as thread is right-hand.

IMPORTANT: The impeller is designed to be self-tightening when running, so impeller may be difficult to break loose. If this is the case, use plastic or rubber hammer on impeller tip to free. Remove impeller.

6. Shaft sleeves are not used.

7. Remove lower seal spring and pry out seal with screwdriver.

8. To remove seal housing, take out socket head bolts and using bolts in back of holes, pry plates loose. This will

force out lower seal if not already removed.

9. Remove snap ring that holds upper seal. Pull seal if it is free. If not free, it can be forced off when shaft is removed.

10. Remove 4 bolts that hold bearing housing in place. Set assembly in upright position and bump end of shaft on hardwood block. This will push the bearing from the housing and will force upper seal from shaft.

11. Use bearing puller to remove bearings. Replace with new bearings. Press only on inner face of bearing when replacing. Pressing on outer face can damage the bearing. Bearings are standard size that can be obtained from any bearing supply house or can be obtained from the Hydromatic factory.

12. IMPORTANT: Do not use any of the old seal parts. Replace with all new seals.

13. Thoroughly clean all castings before replacing seals. One grain of dirt between the seal faces can cause failure.

14. Be sure seal washers are replaced under heads of 4 bolts that hold bearing cap in place. Examine all O-rings for nicks before using.

15. Use Loctite® on socket head locking screw in end of shaft.

Pump Troubleshooting

Below is a list of common problems and the probable causes:

Pump will not start:

1. No power to the motor. Check for blown fuse or open circuit breaker.
2. Selector switch may be in the Off position.
3. Control circuit transformer fuse may be blown.
4. Overload heater on starter may be tripped. Push to reset.

Pump will not start and overload heaters trip:

1. Turn off power and check motor leads with Megger or ohmmeter for possible ground.
2. Check resistance of motor windings. All 3 phases should show the same reading.
3. If no grounds exist and the motor windings check OK, remove pump from sump and check for clogged or blocked impeller.

Pump operates with selector switch in Hand position but will not operate in Auto position:

1. This indicates trouble in the float level control or the alternator relay.
2. Check control panel for trouble.

Pump runs but will not shut off:

1. Pump may be air locked. Turn pump off and let set for several minutes, then restart.

2. Lower float control may be hung-up in the closed position. Check in sump to be sure control is free.
3. Selector switch may be in the Hand position.

Pump does not deliver proper capacity:

1. Discharge gate valve may be partially closed or partially clogged.
2. Check valve may be partially clogged. Raise level up and down to clear.
3. Pump may be running in wrong direction. Low speed pumps can operate in reverse direction without much noise or vibration.
4. Discharge head may be too high. Check total head with gauge when pump is operating. Total head is discharge gauge pressure converted to feet plus vertical height from water level in sump to center line of pressure gauge in discharge line. Gauge should be installed on pump side of all valves. Multiply gauge pressure in pounds by 2.31 to get head in feet.
5. If pump has been in service for some time and capacity falls off, remove pump and check for wear or clogged impeller.

Motor stops and then restarts after short period but overload heaters in starter do not trip:

1. This indicates heat sensors in the motor are tripping due to excessive heat. Impeller may be partially clogged giving a sustained overload but not high enough to trip overload heater switch.

2. Motor may be operating out of liquid due to a failed level control. All Hydromatic S4NRC submersible motors can operate for extended periods out of water without burning up the winding, but the heat sensors give motor prolonged life by controlling winding temperature.
3. Pump may be operating on a short cycle due to sump being too small or from water returning to sump due to a leaking check valve.

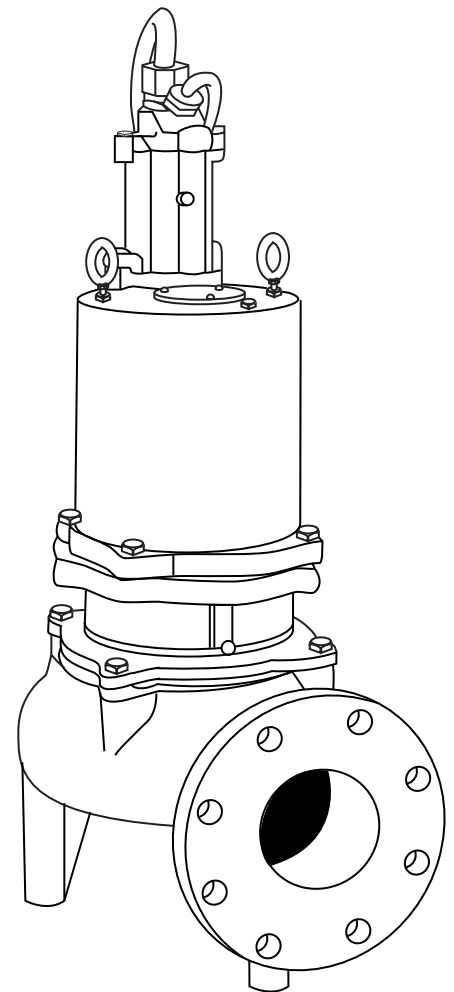

S4NRC Parts List

ORDERING REPLACEMENT PARTS: Product improvements are made from time to time. The latest part design will be furnished as long as it is interchangeable with the old part. When ordering replacement parts, always furnish the following information: (1) pump serial number, (2) pump model and size, (3) part description, (4) part number, (5) impeller diameter (if ordering impeller), (6) quantity required, and (7) shipping instructions.

Ref. No.	Part No.	Part Description	Qty.
1	00853-000-1	Wire Connector (230/3/60)	4
	00557-000-1	Wire Connector (460/3/60)	6
	00557-000-1	Wire Connector (200/230/1/60 & 200/575/3/60)	3
3	14981-001-1	Pipe Plug	5
4	00073-001-1	Wire Connector (Dual Cord)	3
5	05430-002-5	Connection Box Assy. 200/3/60 & 200/1/60	1
	05430-005-5	Connection Box Assy. 230/460/3/60	1
6	00065-021-1	Upper Bearing R	1
7	13425-016-1	Nameplate	1
8	00064-003-1	Load Spring	1
9	04580-001-1	Drive Screw	3
10	00589-002-1	Eyebolt	2
11	01032-003-1	Nut Hex 3/8	2
12	00299-002-1	Stator Retainer Ring	1
13	00517-007-1	Soc. Hd. Cap Screw 1 HP 3ø	4
	00517-008-1	Soc. Hd. Cap Screw All Other HP & ø	4
14	00568-007-1	Soc. Hd. Cap Screw	4
15	07120-000-2	Seal Housing	1
16	07145-000-2	Bearing Housing	1
17	08206-000-1	Instruction Plate	1
18	01024-007-1	Stud	4
19	00852-004-1	Nut	4
20	00834-024-1	O-Ring SC	1
21	00517-004-1	Soc. Hd. Cap Screw	3
22	00300-000-1	Seal (Ceramic) Std.	S 1
	00696-000-1	Seal (Carbide) Opt.	C 1
23	00519-001-1	Lock Washer & Pin Assy.	1
24	00556-003-1	Soc. Hd. Cap Screw	1
25	07144-000-2	Impeller 8" Dia.	1
	07144-006-2	Impeller 7.85" Dia.	1
	07144-008-2	Impeller 7.30" Dia.	1
	07144-009-2	Impeller 7.20" Dia.	1

Ref. No.	Part No.	Part Description	Qty.
	07144-011-2	Impeller 6.40" Dia.	1
	07144-013-2	Impeller 5.90" Dia.	1
	07144-014-2	Impeller 5.50" Dia.	1
26	07143-001-2	Volute Case	1
27	00150-029-1	O-Ring SC	1
28	00975-012-1	Snap Ring	1
29	04916-000-1	Seal SC	1
30	08206-001-1	Instruction Plate	1
31	00065-018-1	Lower Bearing R	1
32	08472-001-5	Seal Failure Assy.	1
33	05899-002-1	Shrinkable Tubing	1
34	00150-057-1	O-Ring SC	1
35	05454-001-1	Spring Pin	1
36	14715-203-1	Stator 1 HP 200/1/60 1150 RPM R	1
	24407C223	Stator 1 HP 230/1/60 1150 RPM R	1
	24407C224	Stator 1 HP 200/3/60 1150 RPM R	1
	24407C225	Stator 1 HP 230/460/3/60 1150 RPM R	1
	24407C226	Stator 1 HP 575/3/60 1150 RPM R	1
	14717-203-1	Stator 2 HP 200/1/60 1150 RPM R	1
	24407C231	Stator 2 HP 230/1/60 1150 RPM R	1
	24407C232	Stator 2 HP 200/3/60 1150 RPM R	1
	24407C233	Stator 2 HP 230/460/3/60 1150 RPM R	1
	24407C234	Stator 2 HP 575/3/60 1150 RPM R	1
	14698-203-1	Stator 3 HP 200/1/60 1750 RPM R	1
	24407C200	Stator 3 HP 230/1/60 1750 RPM R	1
	24407C201	Stator 3 HP 200/3/60 1750 RPM R	1
	24407C202	Stator 3 HP 230/460/3/60 1750 RPM R	1
	24407C203	Stator 3 HP 575/3/60 1750 RPM R	1
	24407C204	Stator 5 HP 230/1/60 1750 RPM R	1
	24407C205	Stator 5 HP 200/3/60 1750 RPM R	1
	24407C206	Stator 5 HP 230/460/3/60 RPM R	1
	24407C207	Stator 5 HP 575/3/60 1750 RPM R	1
	24407C208	Stator 7.5 HP 200/3/60 1750 RPM R	1
	24407C209	Stator 7.5 HP 230/460/3/60 1750 RPM R	1

Ref. No.	Part No.	Part Description	Qty.
	24407C210	Stator 7.5 HP 575/3/60 1750 RPM R	1
37	07774-012-5	Rotor & Shaft Assy. 1 HP 200/230/1/60	1
	07773-012-5	Rotor & Shaft Assy. 1 HP 200/230/460/575/3/60	1
	01329-013-5	Rotor & Shaft Assy. 2 HP 200/230/1/60	1
	00740-013-5	Rotor & Shaft Assy. 2 HP 200/230/460/575/3/60	1
	01329-013-5	Rotor & Shaft Assy. 3-7.5 HP 200/230/1/60 200/230/460/575/3/60	1
38	06000-014-1	Seal Failure Wire Assy.	1
39	00294-002-2	Motor Housing	1
40	00282-001-1	Wire Connector 1ø 575/3/60 & 200/3/60	6
	00282-001-1	Wire Connector 230/460/3/60	12
41	00834-008-1	O-Ring SC	1
42	00834-010-1	O-Ring SC	1
43	05464-030-5	Cord Cap Assy. 30' Dual 10/4	1
	05464-031-5	Cord Cap Assy. 30' Dual 8/4	1
	05464-050-5	Cord Cap Assy. 50' Dual 10/4	1
	05464-051-5	Cord Cap Assy. 50' Dual 8/4	1
44	00101-007-1	Cap Screw	2
45	00238-003-1	Cap Screw	2
46	00736-001-1	Spacer Ring 200/230/1/60 1 HP	1
	00736-003-1	Spacer Ring 200/230/460/575/3/60 1 HP	1
48	00995-008-1	Lock Washer R	4
	51700-017-7	Seal Kit	
	51700-317-7	Carbide Seal Kit	
	*	Rebuild Kit	
47	24709110000	Paraffinic Oil	

Notes: S — Parts in Seal Kit C — Parts in Carbide Seal Kit I — Parts in Impeller Kit R — Parts in Rebuild Kit *Consult Factory
Note: — Fill Oil to above the Motor Windings

S4NRC Parts List

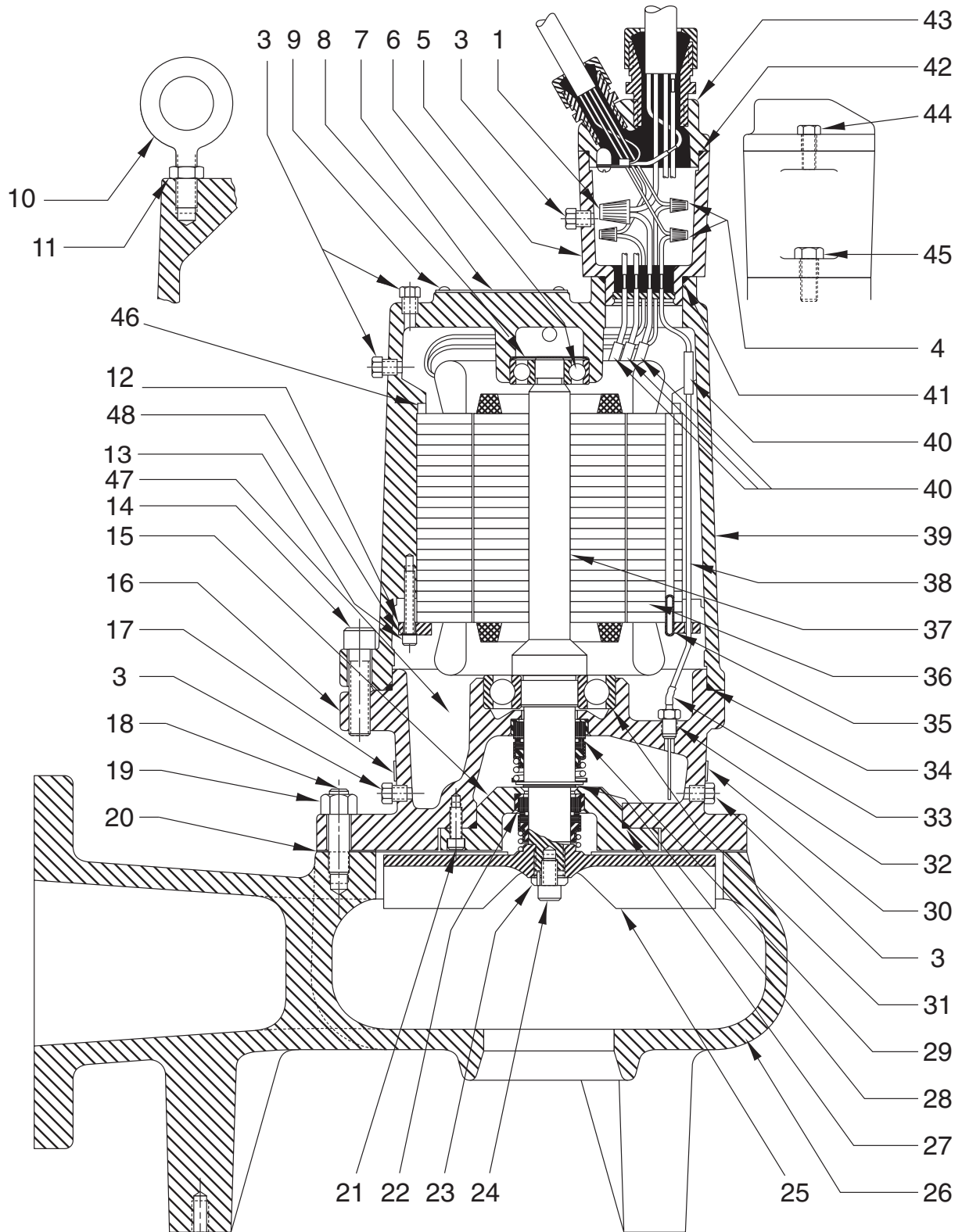

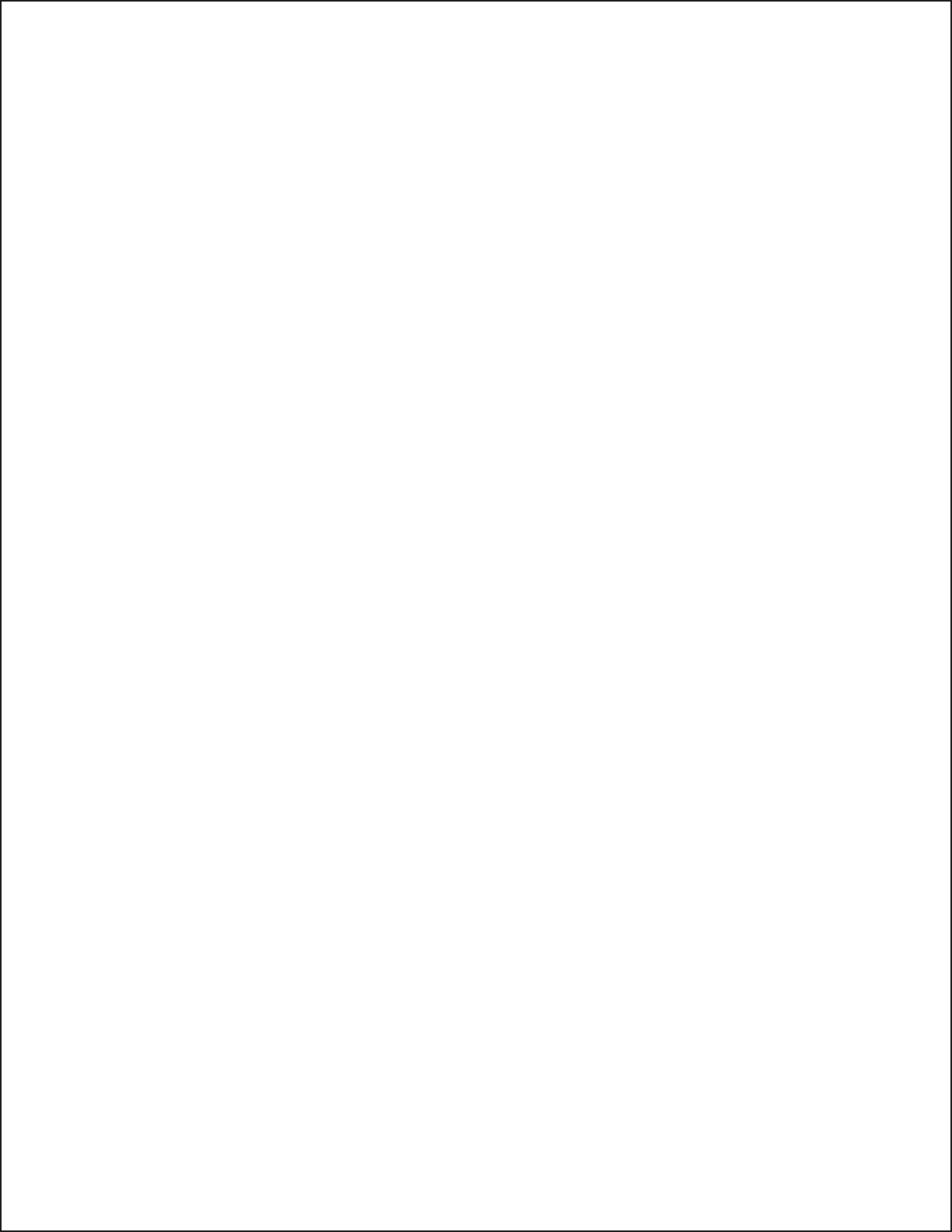

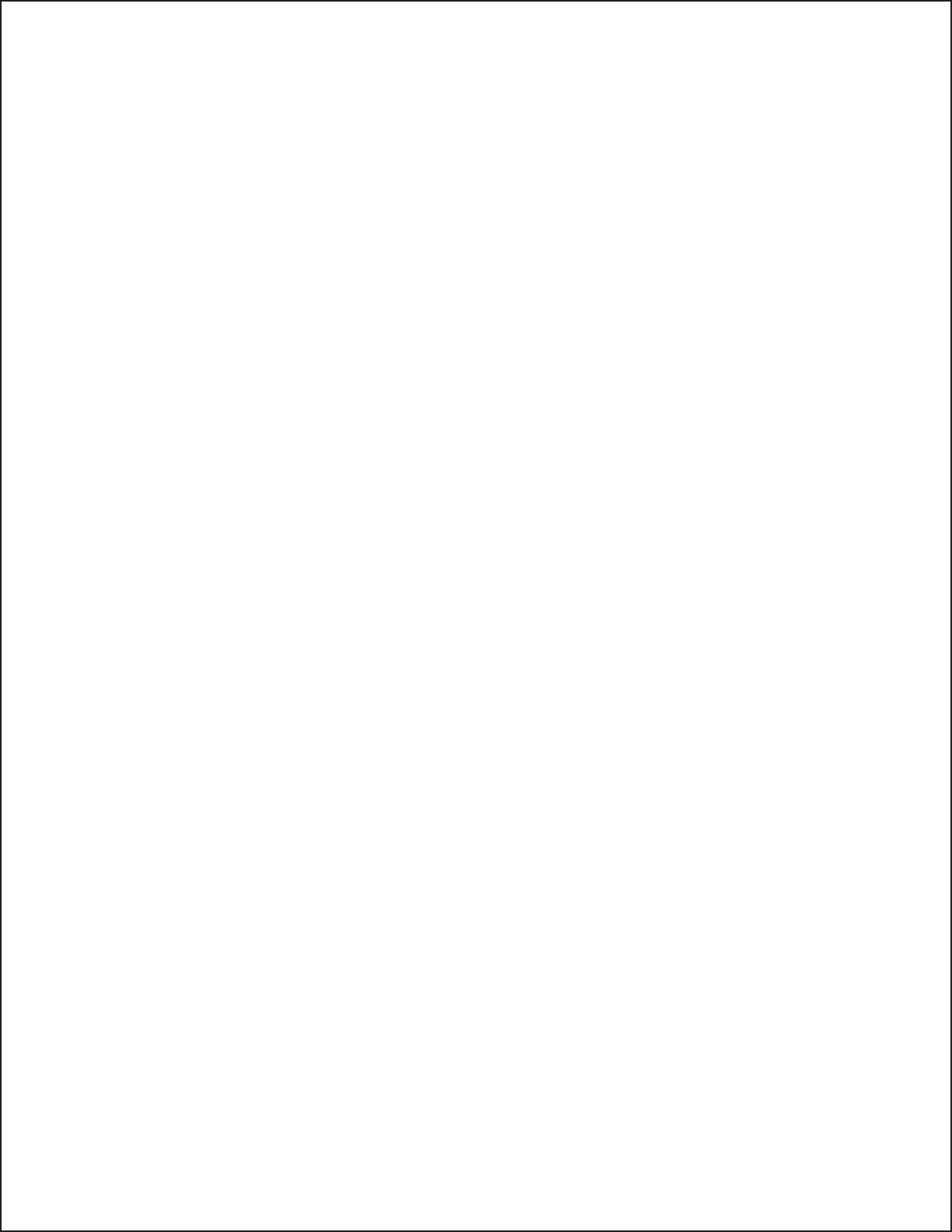

STANDARD LIMITED WARRANTY

HYDROMATIC® warrants its products against defects in material and workmanship for a period of 12 months from the date of shipment from Hydromatic or 18 months from the manufacturing date, whichever occurs first - provided that such products are used compliance with the requirements of the Hydromatic catalog and technical manuals for use in pumping raw sewage, municipal wastewater or similar, abrasive free non-corrosive liquids.

During the warranty period and subject to the conditions set forth, Hydromatic, at its discretion, will repair or replace to the original user, the parts which prove defective in materials and workmanship. Hydromatic reserves the right to change or improve its products or any portions thereof without being obligated to provide such a change or improvement for prior sold and/or shipped units.

Start-up reports and electrical schematics may be required to support warranty claims. Warranty is effective only if Hydromatic authorized control panels are used. All seal fail and heat sensing devices must be hooked up, functional and monitored or this warranty will be void. Hydromatic will only cover the lower seal and labor thereof for all dual seal pumps. Under no circumstance will Hydromatic be responsible for the cost of field labor, travel expenses, rented equipment, removal/reinstallation costs or freight expenses to and from the factory or an authorized Hydromatic service facility.

This limited warranty will not apply: (a) to defects or malfunctions resulting from failure to properly install, operate or maintain the unit in accordance with the printed instructions provided; (b) to failures resulting from abuse, accident or negligence; (c) to normal maintenance services and parts used in connection with such service; (d) to units which are not installed in accordance with applicable local codes, ordinances and good trade practices; (e) if the unit is moved from its original installation location; (f) if unit is used for purposes other than for what it is designed and manufactured; (g) to any unit which has been repaired or altered by anyone other than Hydromatic or an authorized Hydromatic service provider; (h) to any unit which has been repaired using non factory specified/OEM parts.

Warranty Exclusions: HYDROMATIC MAKES NO EXPRESS OR IMPLIED WARRANTIES WHICH EXTEND BEYOND THE DESCRIPTION ON THE FACE HEREOF. HYDROMATIC SPECIFICALLY DISCLAIMS THE IMPLIED WARRANTIES OF MERCHANTABILITY AND FITNESS FOR ANY PARTICULAR PURPOSE.

Liability Limitation: IN NO EVENT SHALL HYDROMATIC BE LIABLE OR RESPONSIBLE FOR CONSEQUENTIAL, INCIDENTAL OR SPECIAL DAMAGES RESULTING FROM OR RELATED IN ANY MANNER TO ANY HYDROMATIC PRODUCT OR PARTS THEREOF. PERSONAL INJURY AND/OR PROPERTY DAMAGE MAY RESULT FROM IMPROPER INSTALLATION. HYDROMATIC DISCLAIMS ALL LIABILITY, INCLUDING LIABILITY UNDER THIS WARRANTY, FOR IMPROPER INSTALLATION. HYDROMATIC RECOMMENDS INSTALLATION BY PROFESSIONALS.

Some states do not permit some or all of the above warranty limitations or the exclusion or limitation of incidental or consequential damages and therefore such limitations may not apply to you. No warranties or representations at any time made by any representatives of Hydromatic shall vary or expand the provision hereof.

	Pentair Water™	- Your Authorized Local Distributor -
USA	740 East 9th Street, Ashland, Ohio 44805 Tel: 419-289-3042 Fax: 419-281-4087	CANADA
	www.hydraulic.com	269 Trillium Drive, Kitchener, Ontario, Canada N2G 4W5 Tel: 519-896-2163 Fax: 519-896-6337

Distributor: _____ Order No.: _____
Installing Contractor: _____ Phone: _____
Sales Contact: _____ Phone: _____
Customer: _____
Location: _____

1. SYSTEM INFORMATION

Size of Wet Well: _____ Manufacturer: _____
Discharge from Bottom of Basin: _____ Discharge Location: _____
Inlet from Bottom of Basin: _____ Inlet Location: _____
Type of Check Valves: _____ Type of Piping: _____
Does System Have Suction Gauges? Yes No Suction Pressure Reading: _____
Does System Have Discharge Gauges? Yes No Discharge Pressure Reading: _____
Liquid Being Pumped: _____ Temperature (F°): _____ Pct. of Solid (%): _____
Is a Sketch or Photograph of System Available? Yes No *If So, Please Attach.*
Any Additional Comments on System: _____

2. ELECTRICAL INFORMATION

Control Panel Part Number: _____ Panel Rated Amps: _____
Manufacturer: _____ Voltage: _____ Phase: _____
Heater Size: _____ Location of Panel to Wet Well: _____
Incoming Line Voltage: _____ Actual? _____
Voltage to Pumps: _____ Actual? _____
Type of Junction Box: _____ Manufacturer of Junction Box: _____
Are Floats Installed in Wet Well? Yes No Are Floats Set to Engineer's Specs? Yes No
Are Floats Wired for Proper Sequencing? Yes No Are Heat Sensors Hooked Up? Yes No
Is the Seal Leak Detection Hooked Up? Yes No
Any Additional Comments on Electrical: _____

3. PUMP INFORMATION

Type of Pump: _____ Serial Number of Pump: _____
Voltage of Pump: _____ Phase: _____ RPM: _____ Amps: _____
Impeller Size: _____ C.O.S. TDH: _____ GPM: _____
Voltage Supplied from Panel: _____ Actual? _____
Actual Amperage (All Phases): Phase 1 Amps: _____ Phase 2 Amps: _____ Phase 3 Amps: _____
Define the Rotation of the Pump: Clockwise Counterclockwise
Method Used to Check Rotation: Viewed from the Top Viewed from the Bottom
Any Additional Comments on Pumps: _____

4. ACKNOWLEDGE

Acknowledge that all information is accurate and proper procedures have been followed.
Customer: _____ Date: _____
Start-up Technician: _____ Date: _____

Send to Warranty Manager, 1101 Myers Parkway, Ashland, OH 44805
or Fax to 419-207-3344
or email to startupreport@hydromatic.com
or submit online at <http://forms.pentairliterature.com/startupform/startupform.asp?type=h>