

Installation and Service Manual

SUBMERSIBLE PUMP WITH HAZARDOUS LOCATION MOTOR END

Model S4MVX (Class I, Division 1, Groups C & D): FM



NOTE! To the installer: Please make sure you provide this manual to the owner of the equipment or to the responsible party who maintains the system.

**For use with product
built with USEM motor.**

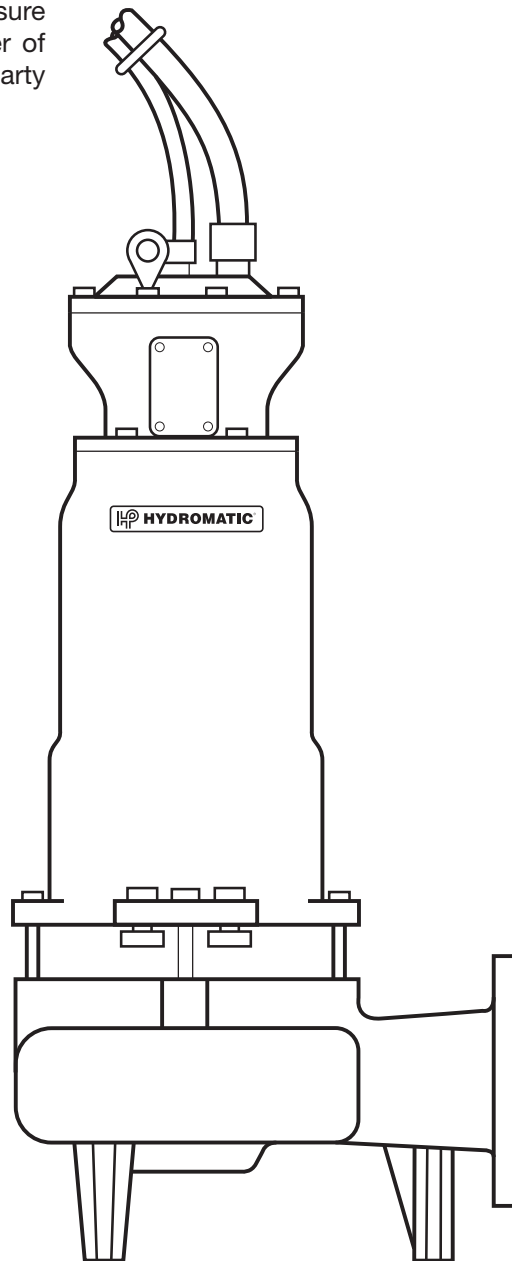

HYDROMATIC[®]
Pentair Water

06/10
Item # E-03-476
Part # 5625-476-1

General Information

Thank you for purchasing your Hydromatic® pump. To help ensure years of trouble-free operation, please read the following manual carefully.

Before Operation:

Read the following instructions carefully. Reasonable care and safe methods should be practiced. Check local codes and requirements before installation.

Attention:

This manual contains important information for the safe use of this product. Read this manual completely before using this product and refer to it often for continued safe product use. **DO NOT THROW AWAY OR LOSE THIS MANUAL.** Keep it in a safe place so that you may refer to it often.

Unpacking Pump:

Remove pump from carton. When unpacking unit, check for concealed damage. Claims for damage must be made at the receiving end through the delivery carrier. Damage cannot be processed from the factory.

WARNING: Before handling these pumps and controls, always disconnect the power first. Do not smoke or use sparkable electrical devices or flames in a septic (gaseous) or possible septic sump.

Pump:

The hazardous location submersible pump family was designed in accordance with requirements for hazardous locations. These pumps, connected properly, will provide years of trouble-free service. If servicing is required, the repair should be done by a Hydromatic approved service center.

Pumps in Storage or Not Operating:

Pumps with carbon ceramic seals must have impellers manually rotated (6 revolutions) after setting non-operational for 3 months or longer and prior to electrical start-up.

Pumps with tungsten carbide seals must have impellers manually rotated (6 revolutions) after setting non-operational for 3 weeks or longer and prior to electrical start-up.

Seal Failure Probes:

All hazardous location submersible pumps have two factory installed moisture detectors (seal failure probes). They are in a normally open series circuit, in the seal chamber. Under normal operating conditions, the circuit remains open. If the lower seal leaks and moisture enters this chamber, the moisture would settle to the bottom of the chamber and will complete the circuit between the moisture detectors.

This circuit must be connected to a sensing unit and signaling device. This is supplied in a Hydromatic built control panel.

NOTE: Failure to install such a device negates all warranties by Hydromatic.

Heat Sensors:

All motors in this family have heat sensors on or embedded in the motor winding to detect excessive heat. This prevents damage to the motor. If sensor trips due to excessive winding temperature, starter in panel breaks power to the pump. Once sensor resets, the starter is automatically reset for FM for continued operation of the pump. This circuitry is supplied in a Hydromatic control panel.

The sensors are set to trip at 120°C (248°F).

NOTE: Failure to install such circuitry would negate FM approvals and all warranties by Hydromatic.

Power Cords:

The power cord and heat sensor seal failure cord are potted into the connection box cap. The cords must not be spliced.

NOTE: Each cable has a green lead. This is the ground wire and must be grounded properly per NEC and/or local codes. Cords should be inspected for abnormal wear and replaced accordingly.

Overload Heaters:

If the Hydromatic electrical panel is not used, starters with 3 leg overload relay must be supplied on 3 phase pumps. Each leg is to have an identical heater sized in accordance with the nameplate amps on the motor housing. The amp draw on these submersible motors is slightly higher than a corresponding horsepower surface motor, so heaters must be sized by the nameplate rating.

Single phase pumps with capacitor start have a run and a start winding each drawing a different current. To adequately protect these windings with the appropriate heaters, consult the factory.

NOTE: Red lead is always start winding of pump using single phase.

Pump Installation

Installing Sump Level Control Float Controls:

In either simplex, duplex or triplex systems the lower or turn-off control is to be set to maintain a minimum level in the sump. This level shall be no more than 3/4" from the top of the motor housing down to the surface of the sewage.

The second or turn-on control is set above the lower turn-off control. The exact distance between the two floats must be a compromise between a frequent pumping cycle (10 starts per hour max.) to control septicity, solids and a slower cycle for energy economy. This distance should be determined by the engineer or consulting engineer depending on the conditions of the application.

For installation of Hydromatic supplied level controls refer to your system's installation and service manual.

Installing Pump in Sump:

Before installing pump in sump, lay it on side and rotate impeller. Impeller may be slightly stuck due to factory test water so it must be broken loose with small bar or screwdriver in edge of vanes. The

impeller should turn freely. *Do not connect the power until after this test.*

Clean all trash and sticks from sump and connect pump to piping. A check valve must be installed on each pump. A gate or plug valve in each pump discharge is highly recommended. This valve should be installed on the discharge side of the check valve so if necessary to service the check valve the line pressure can be cut off. Single pump systems are sometimes installed without a check valve where it is desirable to self-drain the discharge line to prevent freezing. This can be done only with short discharge lines; otherwise water will return to the sump and cause short cycling of the pump.

Making Electrical Connections:

All electrical wiring must be in accordance with local code, and only qualified electricians should make the installations. Complete wiring diagrams are included for use in making the installation. All wires should be checked for shorts to ground with an ohmmeter or Megger after the connections are made. This is important, as one grounded wire can cause considerable trouble.

IMPORTANT: If equipment is not properly wired and protected as recommended, Hydromatic warranty is void. See Page 5.

Heat Sensor and Seal Failure Connections:

If a Hydromatic control panel is used, terminal blocks are provided for heat sensor, seal failure connections (See Panel Schematic). If a control panel is supplied by others, it must allow heat sensor and seal failure terminations.

Pump Operations

Starting System:

1. Double check all wire connections.
2. Turn pumps to Off position on H-O-A switches.
3. Turn on breakers.
- 4A. When using single phase pumps make sure red pump lead is connected to capacitor circuit, connect amprobe to pump power cord and turn pump on. Pump will show high amp draw momentarily, then as pump comes off start wirings, amps will drop to normal nameplate amps.
- 4B. When using three phase pumps (230/460/575), turn H-O-A switch to Hand position on one pump and notice operation. If pump is noisy and vibrates, rotation is wrong. To change rotation, interchange any two line leads to pump. Do not interchange main incoming lines. Check rotation of all pumps in this same manner.
5. Now set both H-O-A switches to Auto position and allow water to rise in sump until one pump starts. Allow pump to operate until the level drops to turn-off point.
6. Allow sump level to rise to start other pump(s). Notice run lights to panel. Pumps should alternate on each successive cycle of operation.
7. Turn both H-O-A switches to Off position and allow sump to fill to the override control level(s).
8. Turn switches to Auto position, and pumps should start and

Pump Operations

operate together until level drops to turn-off point.

9. Repeat this operation cycle several times before leaving job.
10. Check voltage when pumps are operating, and check the amp draw of each pump. Check amps on each wire as sometimes a high leg will exist. One leg can be somewhat higher by 5 to 10 percent without causing trouble. For excessive amp draw on one leg, the electric utility company should be consulted.

Pump Maintenance

As the motors are oil filled, no lubrication or other maintenance is required.

If the heat sensor and seal failure are hooked up properly, no attention is necessary as long as the seal failure indicator light doesn't come on. To ensure continuity of the seal sensor leads, a test light is provided on intrinsically safe Hydromatic panels as standard equipment.

Pump should be checked every quarter for corrosion and wear.

Servicing Instructions:

IMPORTANT: Read all directions before replacing any parts.

WARNING: Before handling these pumps and controls, always disconnect the power first.

Do not smoke or use sparkable electrical devices or flames in a septic (gaseous) or possible septic sump.

Field Service on Hydromatic Hazardous Location Pumps:

If a Hydromatic hazardous location pump is used in a hazardous location the pump must be returned to the factory for service. This will ensure the integrity of the hazardous location rating of the pump and comply with our warranty requirements.

Pumps out of warranty and not used in a hazardous location can be field serviced by any reputable serviceman. When any field servicing is performed on a pump, the following instructions should be followed carefully.

Disconnecting Pump Cords:

If a Hydromatic hazardous location pump is to be removed from its location, one of two ways may be used to disconnect the pump cords from the rest of the system.

Pump cords may be disconnected at control panel (on sump mounted control panels) and cord assembly taken with pump.

CAUTION: If cord openings from sump to control panel are open, gases from sump could enter panel and an explosive condition could exist.

Pump cords may be disconnected at pump by removing the cord and cap assembly, unplugging sensor wires, and removing wire nuts.

After removal from pump, reinstall wire nuts in cord and cap assembly and install

protective cover. (Hydromatic Kit 11159-000-1)

CAUTION: Do not reconnect power to a cord and cap assembly while removing from pump.

Replacing Cords:

The power cord and heat sensor - seal failure cord is potted into the connection box cap, forming the cord and cap assembly.

If cords require replacement due to damage or cords being too short, cord and cap assembly must be replaced as a complete assembly available from factory.

1. Remove cord and cap assembly from connection box.
2. Disconnect wires taking note of color/number coding.
3. Connect wires of new cord and cap assembly in the same manner as the old one was removed.
4. Check for moisture and dryout.
5. Reinstall cord and cap assembly on connection box taking care not to pinch wires.
6. Check pump for proper rotation before returning to normal service.

Replacing Stator:

If motor winding is burned or shorted, it can be rewound or replaced with new factory wound stator. Refer to sectional drawing of pump and motor, and use the following steps to remove and replace stator.

1. If only the stator is damaged, it may not be necessary to completely dismantle pump as stator and housing can be lifted from pump without disturbing seals or bearings.

TYPICAL FM ONLY SCHEMATICS

TYPICAL SINGLE PHASE MOTOR CONNECTIONS

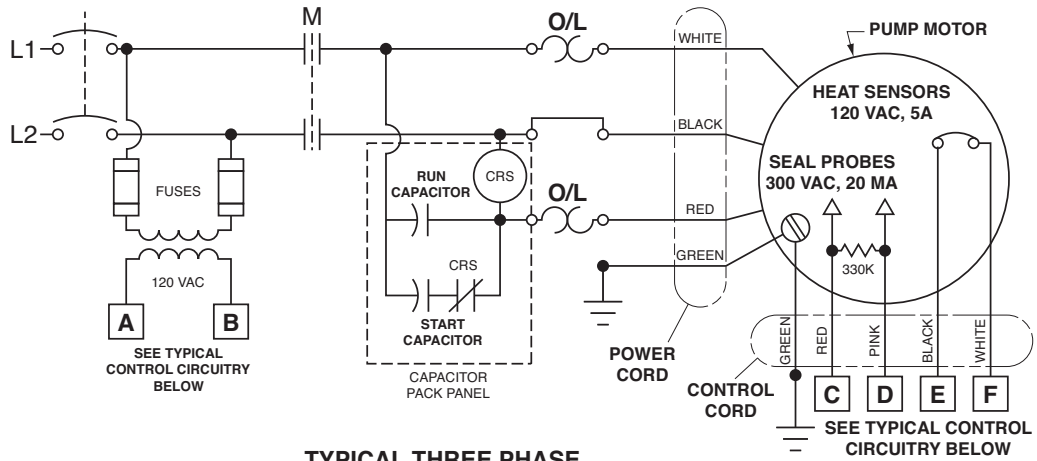

TYPICAL THREE PHASE MOTOR CONNECTIONS

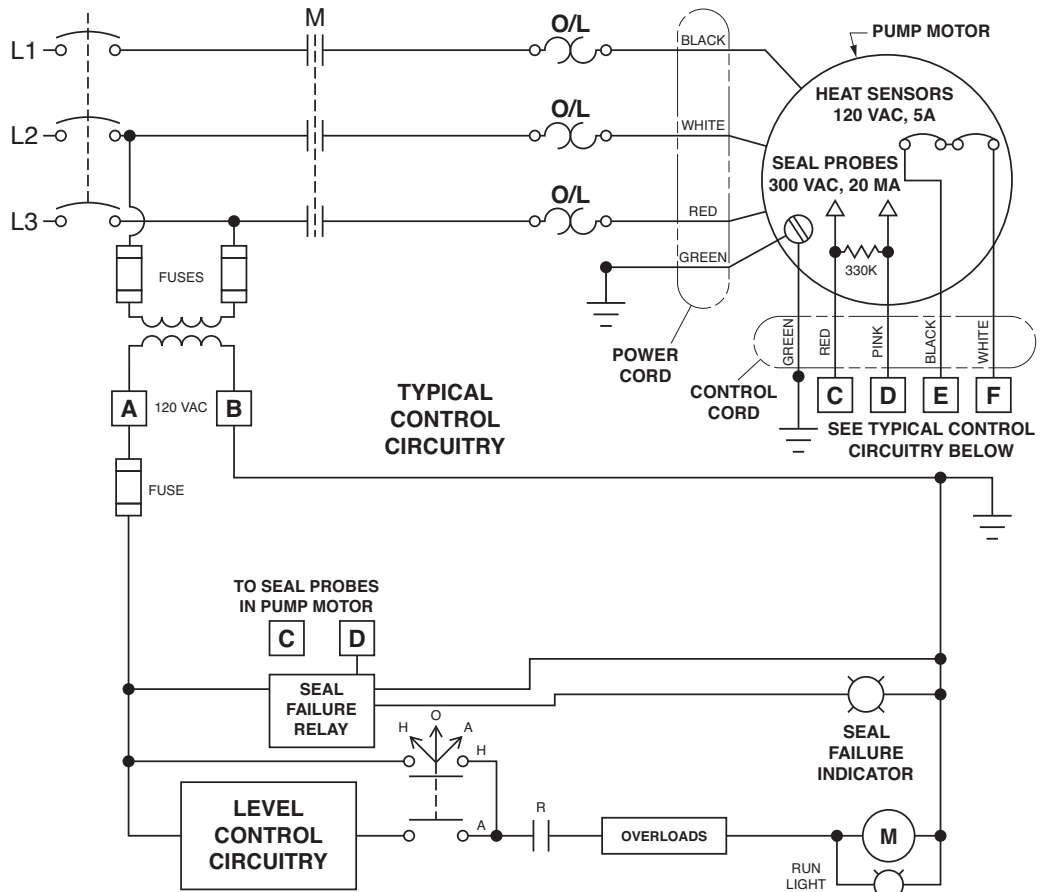

NOTE: CAPACITORS AND/OR CONTROLS SHOULD BE LOCATED OUTSIDE HAZARDOUS AREA AND ENCLOSED IN AN APPROPRIATE ENCLOSURE.

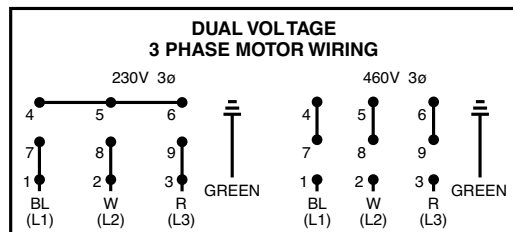

Pump Maintenance

2. Drain all oil from upper housing. Remove drain plug in bottom of bearing housing, and remove connection box to allow air to enter.
3. When connection box is lifted off, connection wires to motor will be exposed. These wires are tagged with a metal marker giving wire number. Disconnect wires and remove connection box.
4. After chamber is drained, remove hold-down bolts on motor housing and lift off. Use care in lifting as the seal failure connecting wire must be disconnected before housing is completely removed. See sectional drawing.
5. The stator is held in the housing with a bolted-in retaining ring and prevented from rotating by a roll pin.
6. Remove the retaining ring and socket head cap screw.
7. After ring is removed, turn housing upright and bump on hardwood block. This should jar the stator loose and allow it to drop out.
8. Thoroughly clean housing before replacing new stator. Replace stator and make all wire connections to connection box before replacing housing on pump. See motor lead connection drawing. This is important as leads must be tucked behind the windings by using hands up through rotor core.

IMPORTANT: Use only butt connections on the wires.

Do not tape leads as oil will deteriorate the tape and cause damage to stator and bearings.

9. Check top bearing. If the bearing is clean and does not turn rough, bearings can be reused. If bearings are damaged with dirt or heat, they must be replaced. See additional instructions on replacing seals and bearings.
10. Replace stator housing onto seal chamber and bolt in place. Be sure seal failure wires are connected before housing is assembled.
Be sure O-ring seal has been replaced. If O-ring is nicked or cut, replace with new ring. This applies to all O-rings used in assembly.
11. After all leads are reconnected in the connection box, make a high voltage ground test on each wire. The only wire that should show ground is the green power lead and the ground head in the auxiliary control cable.
12. For safety, complete pump should be air checked under water for leaks.
Install air valve in plug opening of motor housing and charge housing with about 10 psi of air. Be sure air is dry. Do not use air line where water may be trapped in the line. Submerge complete unit under water and check for leaks. If seals were okay, refill seal chamber with oil. Lay pump on side for this oil filling with oil fill hole upright. Do not completely fill; leave oil about 1" below plug hole. Use only Hydromatic submersible oil or high grade transformer oil in

this chamber. Replace plug; use Permatex on threads.

13. Refill motor chamber with oil through connection box opening. Use high grade, non-synthetic transformer oil or Hydromatic special submersible oil. Fill housing until oil covers top of windings. Leave air space in top for expansion.

NOTE: Oil must cover top of stator.

Replacing Seals and Bearings:

1. Drain all oil from motor chamber and seal chamber as described.
2. Remove motor housing as described in replacing stator.
3. Remove bolts that hold bearing housing to volute. Lift bearing housing and rotating unit off and set assembly on its side. Remove socket head screw and washer at the impeller end of the shaft. Holding the shaft stationary, remove the impeller from the shaft by tapping the end of the impeller blades.
4. To remove seal plate take out socket head screws and using screws in back-off holes, pry plate loose. This will also force seal off if not already removed.
5. Remove snap ring. Pull seal if it is free. If not free, it can be forced off when shaft is removed.
- 5A. The flame ring must be removed. It is recommended Hydromatic Kit #51700-900-7 be used to ease its removal. This kit will include a pusher to reassemble in replacement of flame ring.
6. Set seal housing in upright position and bump end of shaft on hardwood block. This will

push the bearing from the housing and will force upper seal from shaft.

7. Use bearing puller to remove bearings. Replace with new bearings. Press only on inner face of bearing when replacing. Pressing on outer face can damage the bearing. Bearings are standard size that can be obtained from any bearing supply house or can be obtained from Hydromatic factory.

8. **IMPORTANT:** Do not use any of the old seal parts. Replace with all new seals.

NOTE: Any time seal is disturbed, replace seal.

9. Thoroughly clean all castings before replacing seals. One grain of dirt between the seal faces can cause failure.
10. Examine all O-rings for nicks before reusing.
11. Use Loctite (red) on socket head locking screw in end of shaft.

12. Before refilling chamber with oil, air test as described in replacing stator.

13. Refill both chambers with oil as described in replacing stator.

14. Always check all leads with high voltage or with Megger for grounds before operating the pump.

15. Check pump for proper rotation before returning to normal service.

Pump Notes

S4MVX Parts List

For use with product built with USEM motor.

ORDERING REPLACEMENT PARTS: Product improvements are made from time to time. The latest part design will be furnished as long as it is interchangeable with the old part. When ordering replacement parts, always furnish the following information: (1) pump serial number, (2) pump model and size, (3) part description, (4) part number, (5) impeller diameter (if ordering impeller), (6) quantity required, and (7) shipping instructions.

Ref. No.	Part No.	Part Description	Qty.
A2	150-036-1	O-RING 1/8 x 5.234 ID #2-252	1
A3	150-024-1	O-RING 1/8 x 6.734 ID #2-261	2
A4	239-025-1	SCREW – HHC 1/2 – 13UNC	4
A5	65-006-1	BEARING – BALL	1
A6	8346-001-1	KEY 3/8 x 1/4	1
A100	6573-002-1	NUT – EYE 1-1/4" ID	2
A101	1032-002-1	NUT – HEX 3/8 – 16 STL	2
A102	150-019-1	O-RING 1/8 x 6.734 ID #2-261	1
A103	1027-010-1	STUD – 3/8" x 2-1/4" LG	2
A104	19101A052	SCREW – HHC 1/2 – 13UNC x 1-1/4	4
A105	10898-000-1	CONNECTOR – ELEC	4
A106	9176-000-1	SLEEVE – WIRE 5/8	6 FT
A107	975-019-1	SNAP RING	1
A108	10571-000-2	HOUSING – MOTOR	1
A109	10900-002-5	SEAL SENSOR ASSY	1
A110	11067-000-1	LUBRICANT – OIL	0.09
A111	10754-000-2	PLATE – SEAL	1

Ref. No.	Part No.	Part Description	Qty.
A112	10901-000-1	SEAL FAILURE PROBE	2
A113	19101A021	SCREW – HHC 3/8 – 16UNC x 1-1/2	4
A114	10744-000-2	HOUSING – BEARING	1
A115	10902-000-1	WIRE – SAFETY	1 EX
A116	924-011-1	PLUG – PIPE 1/2	2
A117	150-031-1	O-RING 1/8 x 3.984 ID #2-242	1
A119	105-014034-263	SCREW – CAP (HEX SOC.)	4
A120	10782-002-3	RING – LABYRINTH	1
A121	975-019-1	RING – RETAIN. (EXT)	1
A122	178-008-1	SCREW – CAP (HEX SOC.)	4
A123	7074-000-3	RING – RETAINING STATOR	1
A124	65-027-1	BEARING – BALL	1
A125	64-007-1	SPRING – BEARING ADJ.	2
A126	11065-001-3	SCREEN – 2.62 DIA.	1
A127	19101A017	SCREW – HHC 3/8 – 16UNC x 1-1/2	4
A128	517-003-1	SCREW – CAP (HEX SOC.)	2
A129	10300-060-1	CORD – WAXED	1
A130	24709110000	OIL – PARAFFINIC	2.0 GAL

Ref. No.	Part No.	Part Description	Qty.
A131	13425-034-1	NAMEPLATE	1
A132	4580-001-1	SCREW – DRIVE	4
C1	11049-001-1	Carbon Ceramic / Buna-n	1
	11049-001-1	Tungsten Carbide / Buna-n	
C2	8100-000-4	Carbon Ceramic / Buna-n	1
	8100-002-4	Tungsten Carbide / Buna-n	
D2	568-002-1	SCREW – CAP	1
D3	8023-000-1	WASHER – IMPELLER SST	1
D4	7080-000-2	VOLUTE	1
1	7081-008-2	IMPELLER, 6.75"	1
	7081-002-2	IMPELLER, 8"	
	7081-001-2	IMPELLER, 8.5"	
	7081-013-2	IMPELLER, 8.69"	
	7081-000-2	IMPELLER, 9"	

PUMP DESCRIPTION	PUMP PART #	HP	V/Ø/RPM	Connection Box (B1)	Rotor/ Shaft Assy (B2)	Stator (B3)	Connector – box to cord cap (B4)	Spacer (B5)	Connector – Wire (B6)	Connector – Butt (B7)
S4MVX500BC	51627-011-7	5	230/1/1750	11408-000-5	14142-012-5	14142-201-1	2494-000-1(3)	736-006-1	-	11675-000-1(3)
S4MVX500CC	51627-017-7	5	230/1/1750	11408-000-5	14142-012-5	14142-001-1	2494-000-1(3)	736-006-1	-	11675-000-1(3)
S4MVX750CC	51627-024-7	7.5	230/1/1750	11408-000-5	14144-012-5	14144-001-1	2494-000-1(3)	-	-	11691-000-1(3)
S4MVX500DC	51627-010-7	5-7.5	200/3/1750	11408-000-5	14139-012-5	14140-203-1	2494-000-1(3)	736-006-1	-	11675-000-1(3)
S4MVX750DC	51627-012-7	5-7.5	200/3/1750	11408-000-5	14139-012-5	14140-203-1	2494-000-1(3)	736-006-1	-	11675-000-1(3)
S4MVX750EC	51627-007-7	5-7.5	230/3/1750	11408-001-5	14139-012-5	14140-003-1	2494-000-1(3)	736-006-1	2493-000-1 (1)	11675-000-1(9)
S4MVX750FC	51627-003-7	5-7.5	460/3/1750	11408-001-5	14139-012-5	14140-003-1	2494-000-1(3)	736-006-1	2493-000-1 (3)	11675-000-1(9)
S4MVX750GC	51627-019-7	5-7.5	575/3/1750	11408-000-5	14139-012-5	14140-603-1	-	736-006-1	2493-000-1 (3)	11675-000-1(3)
S4MVX500EC	51627-006-7	5-7.5	230/3/1750	11408-001-5	14139-012-5	14140-003-1	2494-000-1(3)	736-006-1	2493-000-1 (1)	11675-000-1(9)
S4MVX500FC	51627-014-7	5-7.5	460/3/1750	11408-001-5	14139-012-5	14140-003-1	2494-000-1(3)	736-006-1	2493-000-1 (3)	11675-000-1(9)
S4MVX500GC	51627-018-7	5-7.5	575/3/1750	11408-000-5	14139-012-5	14140-603-1	-	736-006-1	2493-000-1 (3)	11675-000-1(3)
S4MVX1000DC	51627-202-7	10	200/3/1750	11408-000-5	14141-012-5	14141-203-1	2494-000-1(3)	-	-	11691-000-1(3)
S4MVX1000EC	51627-001-7	10	230/3/1750	11408-001-5	14141-012-5	14141-003-1	2494-000-1(3)	-	2493-000-1 (1)	11675-000-1(9)
S4MVX1000FC	51627-013-7	10	460/3/1750	11408-001-5	14141-012-5	14141-003-1	2494-000-1(3)	-	2493-000-1 (3)	11675-000-1(9)
S4MVX1000GC	51627-020-7	10	575/3/1750	11408-000-5	14141-012-5	14141-603-1	-	-	2493-000-1 (3)	11675-000-1(3)
S4MVX1500DC	51627-004-7	15	200/3/1750	11408-002-5	14141-012-5	14143-203-1	2498-005-1 (3)	-	-	23394A002(3)
S4MVX1500EC	51627-002-7	15	230/3/1750	11408-003-5	14141-012-5	14143-003-1	2494-000-1(3)	-	2498-005-1 (1)	11691-000-1(9)
S4MVX1500FC	51627-015-7	15	460/3/1750	11408-001-5	14141-012-5	14143-003-1	2494-000-1(3)	-	2493-000-1 (3)	11675-000-1(9)
S4MVX1500GC	51627-021-7	15	575/3/1750	11408-000-5	14141-012-5	14143-603-1	-	-	2493-000-1 (3)	11675-000-1(3)
S4MVX300DB	51627-201-7	3-5	200/3/1150	11408-000-5	14139-012-5	14297-203-1	-	736-006-1	2493-000-1(3)	11675-000-1(3)
S4MVX300EB	51627-203-7	3-5	230/3/1150	11408-001-5	14139-012-5	14297-003-1	-	736-006-1	2493-000-1(4)	11675-000-1(9)
S4MVX300FB	51627-016-7	3-5	460/3/1150	11408-001-5	14139-012-5	14297-003-1	-	736-006-1	2493-000-1(6)	11675-000-1(9)
S4MVX300GB	51627-022-7	3-5	575/3/1150	11408-000-5	14139-012-5	14297-603-1	-	736-006-1	2493-000-1(3)	11675-000-1(3)
S4MVX500DB	51627-200-7	3-5	200/3/1150	11408-000-5	14139-012-5	14297-203-1	-	736-006-1	2493-000-1(3)	11675-000-1(3)
S4MVX500EB	51627-008-7	3-5	230/3/1150	11408-001-5	14139-012-5	14297-003-1	-	736-006-1	2493-000-1(4)	11675-000-1(9)
S4MVX500FB	51627-005-7	3-5	460/3/1150	11408-001-5	14139-012-5	14297-003-1	-	736-006-1	2493-000-1(6)	11675-000-1(9)
S4MVX500GB	51627-023-7	3-5	575/3/1150	11408-000-5	14139-012-5	14297-603-1	-	736-006-1	2493-000-1(3)	11675-000-1(3)

Note: — Fill Oil to above the Motor Windings

S4MVX

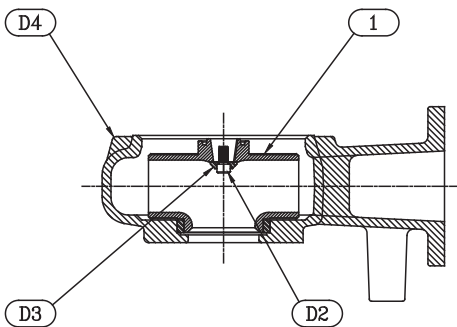
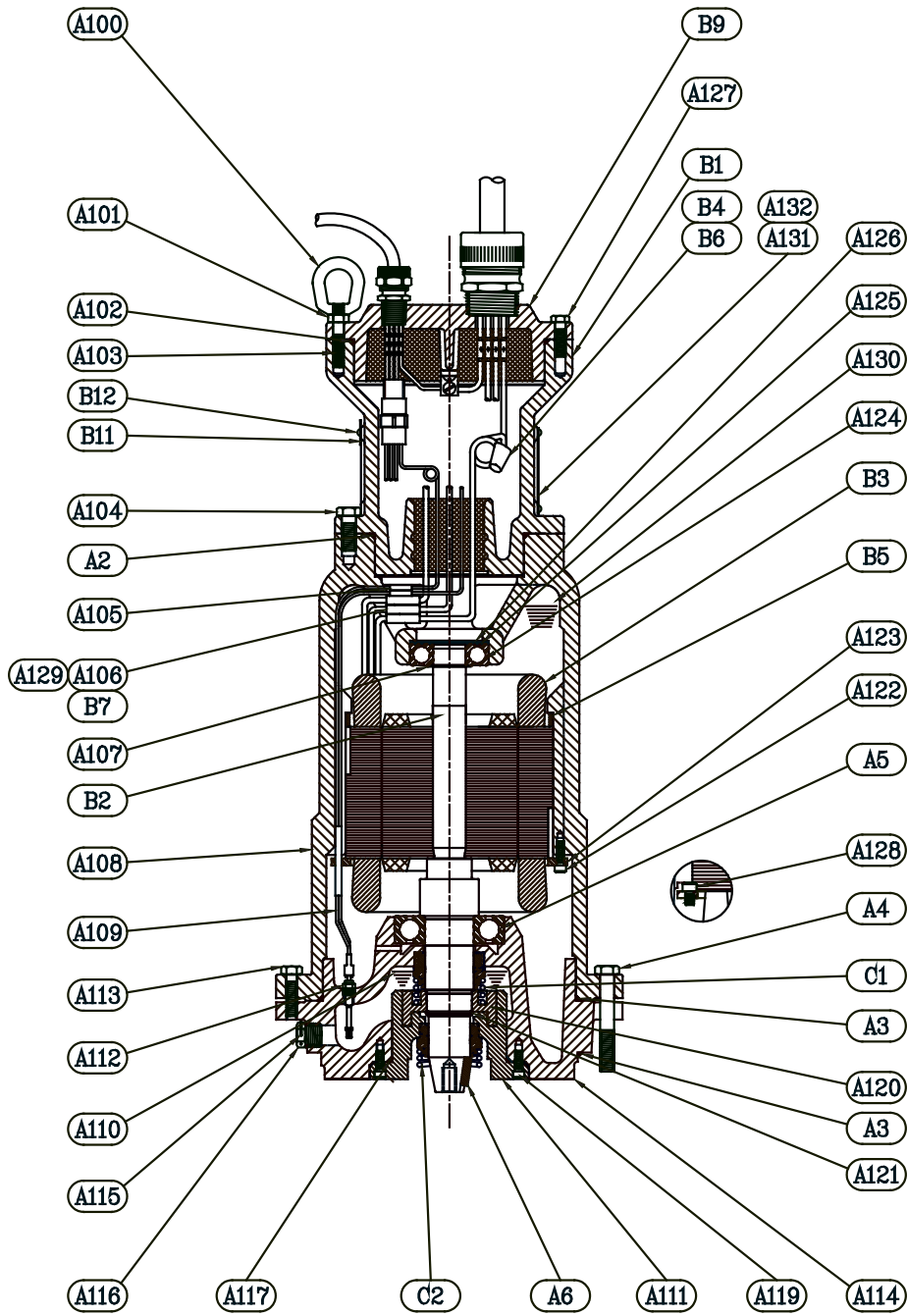

STANDARD LIMITED WARRANTY

HYDROMATIC® warrants its products against defects in material and workmanship for a period of 12 months from the date of shipment from Hydromatic or 18 months from the manufacturing date, whichever occurs first - provided that such products are used in compliance with the requirements of the Hydromatic catalog and technical manuals for use in pumping raw sewage, municipal wastewater or similar, abrasive free non-corrosive liquids.

During the warranty period and subject to the conditions set forth, Hydromatic, at its discretion, will repair or replace to the original user, the parts which prove defective in materials and workmanship. Hydromatic reserves the right to change or improve its products or any portions thereof without being obligated to provide such a change or improvement for prior sold and/or shipped units.

Start-up reports and electrical schematics may be required to support warranty claims. Warranty is effective only if Hydromatic authorized control panels are used. All seal fail and heat sensing devices must be hooked up, functional and monitored or this warranty will be void. Hydromatic will only cover the lower seal and labor thereof for all dual seal pumps. Under no circumstance will Hydromatic be responsible for the cost of field labor, travel expenses, rented equipment, removal/reinstallation costs or freight expenses to and from the factory or an authorized Hydromatic service facility.

This limited warranty will not apply: (a) to defects or malfunctions resulting from failure to properly install, operate or maintain the unit in accordance with the printed instructions provided; (b) to failures resulting from abuse, accident or negligence; (c) to normal maintenance services and parts used in connection with such service; (d) to units which are not installed in accordance with applicable local codes, ordinances and good trade practices; (e) if the unit is moved from its original installation location; (f) if unit is used for purposes other than for what it is designed and manufactured; (g) to any unit which has been repaired or altered by anyone other than Hydromatic or an authorized Hydromatic service provider; (h) to any unit which has been repaired using non factory specified/OEM parts.

Warranty Exclusions: HYDROMATIC MAKES NO EXPRESS OR IMPLIED WARRANTIES WHICH EXTEND BEYOND THE DESCRIPTION ON THE FACE HEREOF. HYDROMATIC SPECIFICALLY DISCLAIMS THE IMPLIED WARRANTIES OF MERCHANTABILITY AND FITNESS FOR ANY PARTICULAR PURPOSE.

Liability Limitation: IN NO EVENT SHALL HYDROMATIC BE LIABLE OR RESPONSIBLE FOR CONSEQUENTIAL, INCIDENTAL OR SPECIAL DAMAGES RESULTING FROM OR RELATED IN ANY MANNER TO ANY HYDROMATIC PRODUCT OR PARTS THEREOF. PERSONAL INJURY AND/OR PROPERTY DAMAGE MAY RESULT FROM IMPROPER INSTALLATION. HYDROMATIC DISCLAIMS ALL LIABILITY, INCLUDING LIABILITY UNDER THIS WARRANTY, FOR IMPROPER INSTALLATION. HYDROMATIC RECOMMENDS INSTALLATION BY PROFESSIONALS.

Some states do not permit some or all of the above warranty limitations or the exclusion or limitation of incidental or consequential damages and therefore such limitations may not apply to you. No warranties or representations at any time made by any representatives of Hydromatic shall vary or expand the provision hereof.

 HYDROMATIC®	– Your Authorized Local Distributor –
USA 740 East 9th Street, Ashland, Ohio 44805 Tel: 419-289-3042 Fax: 419-281-4087	CANADA 269 Trillium Drive, Kitchener, Ontario, Canada N2G 4W5 Tel: 519-896-2163 Fax: 519-896-6337
www.hydromatic.com	

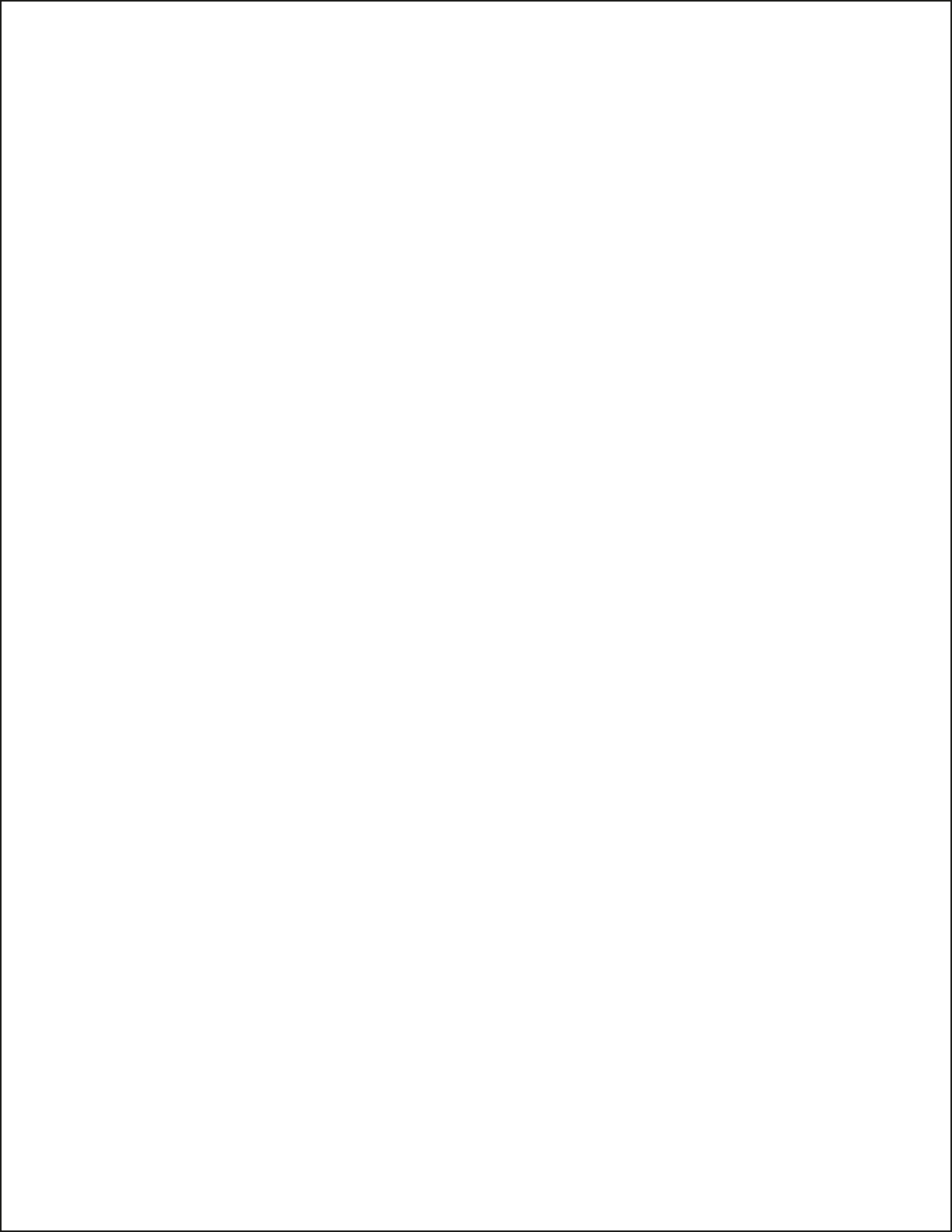

Distributor: _____ Order No.: _____
Installing Contractor: _____ Phone: _____
Sales Contact: _____ Phone: _____
Customer: _____
Location: _____

1. SYSTEM INFORMATION

Size of Wet Well: _____ Manufacturer: _____
Discharge from Bottom of Basin: _____ Discharge Location: _____
Inlet from Bottom of Basin: _____ Inlet Location: _____
Type of Check Valves: _____ Type of Piping: _____
Does System Have Suction Gauges? Yes No Suction Pressure Reading: _____
Does System Have Discharge Gauges? Yes No Discharge Pressure Reading: _____
Liquid Being Pumped: _____ Temperature (F°): _____ Pct. of Solid (%): _____
Is a Sketch or Photograph of System Available? Yes No *If So, Please Attach.*
Any Additional Comments on System: _____

2. ELECTRICAL INFORMATION

Control Panel Part Number: _____ Panel Rated Amps: _____
Manufacturer: _____ Voltage: _____ Phase: _____
Heater Size: _____ Location of Panel to Wet Well: _____
Incoming Line Voltage: _____ Actual? _____
Voltage to Pumps: _____ Actual? _____
Type of Junction Box: _____ Manufacturer of Junction Box: _____
Are Floats Installed in Wet Well? Yes No Are Floats Set to Engineer's Specs? Yes No
Are Floats Wired for Proper Sequencing? Yes No Are Heat Sensors Hooked Up? Yes No
Is the Seal Leak Detection Hooked Up? Yes No
Any Additional Comments on Electrical: _____

3. PUMP INFORMATION

Type of Pump: _____ Serial Number of Pump: _____
Voltage of Pump: _____ Phase: _____ RPM: _____ Amps: _____
Impeller Size: _____ C.O.S. TDH: _____ GPM: _____
Voltage Supplied from Panel: _____ Actual? _____
Actual Amperage (All Phases): Phase 1 Amps: _____ Phase 2 Amps: _____ Phase 3 Amps: _____
Define the Rotation of the Pump: Clockwise Counterclockwise
Method Used to Check Rotation: Viewed from the Top Viewed from the Bottom
Any Additional Comments on Pumps: _____

4. ACKNOWLEDGE

Acknowledge that all information is accurate and proper procedures have been followed.

Customer: _____ Date: _____
Start-up Technician: _____ Date: _____

Send to Warranty Manager, 1101 Myers Parkway, Ashland, OH 44805
or Fax to 419-207-3344

or email to startupreport@hydromatic.com

or submit online at <http://forms.pentairliterature.com/startupform/startupform.asp?type=h>