



HYDROMATIC®

HCU15, HCU15S, HCU20S

Condensate Units



The Hydromatic Condensate units are designed to automatically remove the liquid from an air conditioner evaporative coil and/or a gas condensing warm air furnace. These units are made from a tough ABS plastic so they will resist corrosion and impacts.



Pentair
Water™

HCU15, HCU15S, HCU20S – Condensate Units

Details

Pump Characteristics

Pump/Motor Unit	Condensate Unit
Capacities	120 GPH
Heads	20 ft.
Liquids	Drain Water
Tank Capacities	2.0 Quarts
Temperature	190°F
Motor Type	Electrical
Full Load Amps	1.45
Voltage	115
Hertz	60
Unit Weight	3.25 lbs.
Dimensions	11" x 5" x 4-3/4"
Housing	Thermoplastic
Power Cord Size	6'

Performance Curve

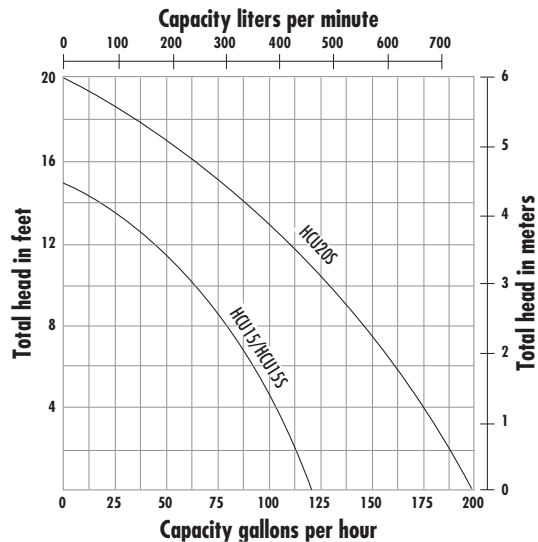

Performance Chart

HEAD-FEET	FLows (GPH) HCU15/15S	FLows (GPH) HCU20S
0	120	200
5	90	170
10	65	130
15	0	80
20	0	0

Items Included

- Condensate Unit with 6' power cord.
- Check Valve to prevent backflow of liquid into the unit.
- Overflow Safety Switch. (Models HCU15S/HCU20S)
- Instruction Manual.

Dimensional Data

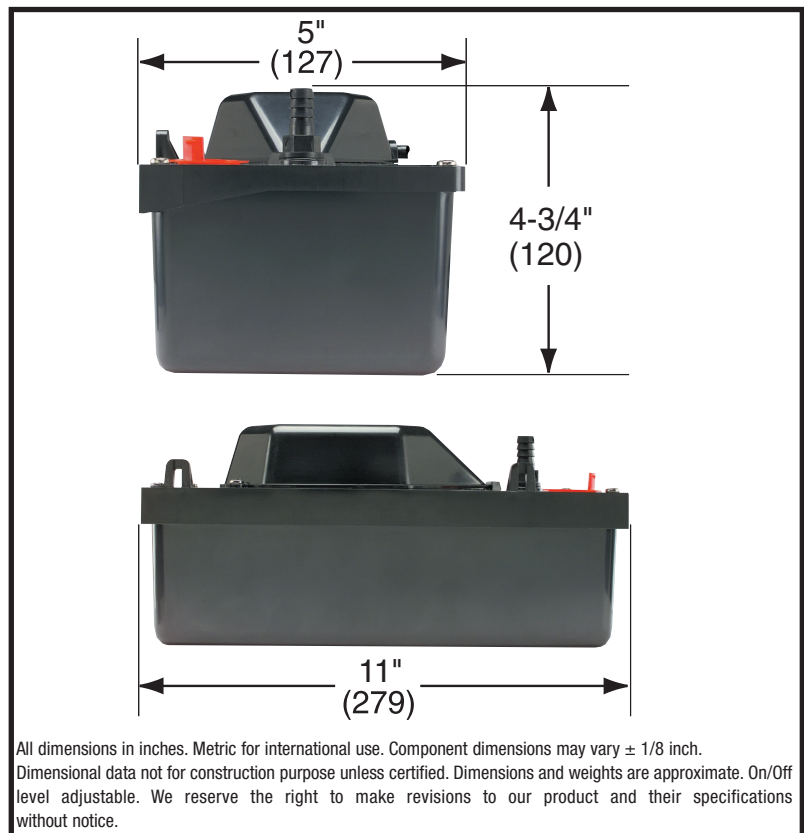

USA

740 East 9th Street, Ashland, Ohio 44805
Tel: 419-289-3042 Fax: 419-281-4087



www.hydromatic.com

– Your Authorized Local Distributor –

CANADA

269 Trillium Drive, Kitchener, Ontario, Canada N2G 4W5
Tel: 519-896-2163 Fax: 519-896-6337