

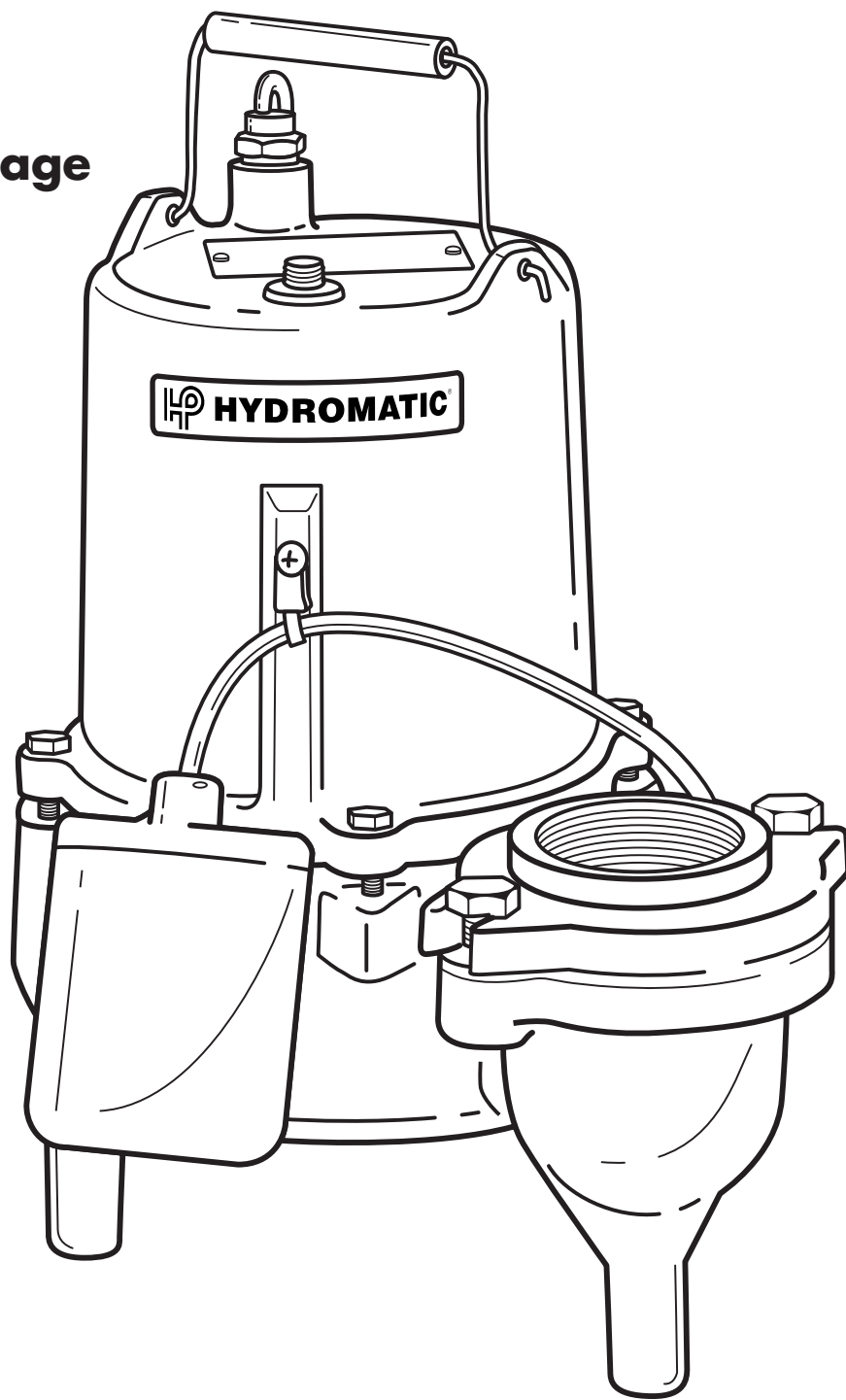

HYDROMATIC[®]

SK50

**Submersible Sewage
Ejector Pump**



NOTE! To the installer: Please make sure you provide this manual to the owner of the pumping equipment or to the responsible party who maintains the system.



**Pentair
Water[™]**

General Information

Thank you for purchasing your Hydromatic® pump. To help ensure years of trouble-free operation, please read the following manual carefully.

Before Operation:

Read the following instructions carefully. Reasonable care and safe methods should be practiced. Check local codes and requirements before installation.

Attention:

This manual contains important information for the safe use of this product. Read this manual completely before using this product and refer to it often for continued safe product use. **DO NOT THROW AWAY OR LOSE THIS MANUAL.** Keep it in a safe place so that you may refer to it often.

WARNING: Before handling these pumps and controls, always disconnect the power first. Do not smoke or use sparkable electrical devices or flames in a septic (gaseous) or possible septic sump.

Pump Warning

To reduce risk of electrical shock:

1. Risk of Electrical Shock:

This pump has not been investigated for use in swimming pool areas.

2. Risk of Electrical Shock:

Connect only to a properly grounded receptacle.

Septic tank is to be vented in accordance with local plumbing codes.

Do not smoke or use sparkable electrical devices or flame in a septic (gaseous) or possible septic sump.

If a septic sump condition exists and if entry into sump is necessary, then (1) provide proper safety precautions per OSHA requirements and (2) do not enter sump until these precautions are strictly adhered to.

Do not install pump in location classified as hazardous per N.E.C., ANSI/NFPA 70 - 2001.

Failure to heed above cautions could result in injury or death.

Pump Installation

These important instructions must be followed for satisfactory performance of your pump. Before installation, check your local electrical and plumbing codes.

1. Provide proper sump. Recommended minimum sump diameter is 18".
2. Make sure sump is free of string, cloth, nails, gravel, etc. before installing pump.
3. Do not set pump directly on the bottom of sump pit if it is not solid. Raise the pump by placing bricks or concrete blocks underneath it.
4. Use steel or plastic pipe for all connecting lines between pump and sewer outlet.

Note: Some city regulations do not allow installing a pump with plastic pipe. Check local regulations.

5. In applications where the pump may sit idle for months at a time, it is recommended that the pump(s) be cycled every month to ensure the pumping system is working properly when needed.
6. Hydromatic check valve should be installed in discharge pipe.
7. An audible alarm system, such as the Q Alert, for high water conditions should be installed in every pump pit for greater protection.

Note: The Q Alert is for indoor use only. For outdoor applications contact your Hydromatic distributor.

8. Connect to power source using 3-prong grounded AC receptacle. Do not remove ground pin from electrical plug. Do not use an extension cord or adaptor plug.
9. For proper automatic operation, make sure the pump power cord is plugged into the back of the piggyback receptacle on the wide angle float switch.
10. Use pump partially or completely submerged for pumping waterlike liquids (temperature to 140° F). The SK50 will pump solid materials up to 2" (spherical) in diameter. This pump has not been investigated for use in swimming pool areas.
11. **Caution:** Do not pump flammable liquids, strong chemicals or salt water.

Pump Servicing

Read the following instructions carefully before replacing any parts. Reasonable care and safe methods should be practiced. Check local codes and requirements before installation. Only competent electrician should make the installations.

The following steps should be performed by an authorized Hydromatic service center or distributor.

Note: Use extreme caution around electrical devices. Electrical shock may occur.

1. Before removing pump from the sump, check to be sure the problem is not a blown fuse, tripped circuit breaker or a power cord not completely inserted into the receptacle.
2. If the unit is being operated by an optional float control switch, unplug the pump from the piggyback receptacle and plug the pump directly into the power source. If the pump starts each time it is plugged directly into the receptacle and does not start each time when plugged into the piggyback switch with the float raised or diaphragm pressed up to a start position, replace the complete switch assembly and retest with new assembly.
3. If pump fails the above two steps, remove pump and switch from power source to avoid electrical shock. Then pull the pump from the sump by the handle. Sandblast, if possible, any dirt or trash

from the outside of the pump before dismantling.

4. If the above tests have not resolved the problem, it may be in the electrical components of the pump. Starting with the power cord, inspect for cuts or nicks in the insulation. If the cord is damaged – replace it!
5. Using the ohmmeter, check the resistance of the motor windings by connecting one lead clip to each electrical “flat” prong on the power cord plug. The ohmmeter should be on R X 1 setting. Normal readings are .9 to 1.1 ohms for 115V, 2.9 to 3.4 for 230V.

To check the ground, place the ohmmeter on R X 100k, connect one lead clip to the “ground” prong on the power cord and touch the other lead clip to each “flat” prong individually. If the reading is other than infinity (∞ on the ohmmeter scale), a leakage through stator insulation or moisture in the windings is occurring and the stator must be removed, dried out and rechecked. A reading at zero indicates a dead short and the stator will have to be replaced.
6. To check to see if water has entered the motor cap, remove the pipe plug (3) at the top of the pump and drain the oil into a bucket. A milky appearance to the oil indicates that water has entered through either worn or damaged seals or O-rings and replacement is necessary.
7. Remove the four hex-head screws (8) from the motor housing and lift off the motor housing (21) very carefully as a grounding wire is attached to the inside of the motor housing (21). Remove the ground screw (22) and set the motor housing (21) aside.

8. To remove impeller, hold the rotor shaft assembly with screwdriver (screwdriver slot in shaft). Carefully tap impeller off shaft with a plastic or rubber hammer. Tap impeller (12) counterclockwise to remove. Loctite #277 is applied to shaft at assembly, so to remove impeller it will be necessary to break this seal. This is why the plastic or rubber hammer is used to avoid damage to the impeller.
9. Insert a screwdriver under the edge of the ceramic seal (11) and lift it off.
10. Remove the stationary half of the seal (10) by tapping it out lightly from the top of the seal plate and then clean the area with a cloth.
11. Remove the four bolts holding the motor (20) onto the seal plate (13) and tap the shaft and rotor assembly out with a plastic or rawhide hammer. The lower ball bearing will come out with the shaft and rotor assembly. If the bearing is rusted or feels rough when turned, it should be replaced as in Step 13.
12. Coat the replacement seal (10) with a thin oil (dielectric, same as in motor housing) coating and use a plastic pusher to install the seal (10) into the seal plate (13). Do not use any sharp instruments that may damage the seal. Do not chip, scratch or mar the carbon face.
13. If ball bearing replacement is necessary as determined in Step 11, press the bearing on the shaft pushing only on the inner face. If a press is not available, the bearing can be tapped on using a sleeve that bears only on the inner face.

SK50



Typical Installation

Pump Servicing

Pressing on the outer face will result in flat spots on the bearing and cause early failure.

14. Push the new rotor shaft and ball bearing assembly into the seal plate. (Note that the replacement rotor must be of the same manufacture as the existing stator, or vice versa.) Reassemble the motor (20) to the seal plate (13) with the four long cap screws. Be sure to tighten down the bolts evenly and firmly to prevent cocking of the stator. An uneven assembly can cause the rotor to rub the motor causing the motor to short.
15. Press the new ceramic seal (11) in place with the rubber ring facing the impeller. This should have a thin oil (dielectric, same as in motor housing) coating.

Note: Ceramic must be kept clean. Any dirt will cause seal failure.

16. Start the impeller on the shaft one to two turns; then, add a drop of Loctite #277 to the impeller threads and screw the impeller hand tight. The impeller will force the ceramic seal into position. The shaft should be free of dirt, grease, etc., or the Loctite will not hold as designed.

Note: Loctite overrun onto the seal or bearing will result in shaft seizure.

17. Remove the old seal ring (18) and stretch on new ring with O-ring lube.

Do not roll the ring onto seal plate or water leakage into the motor housing will result.

18. Fasten the ground wire inside the motor housing and tuck wires up into the housing to prevent rubbing on the rotor; then assemble housing (21) to volute (14) with bolts (8).

19. Check for seal leaks by pressurizing the pump to 7 to 9 pounds of air pressure. Air bubbles should appear at first then stop. If air bubbles continue, recheck seals.

20. Fill the motor cap with high-grade transformer oil such as Sohio (5) Factopure SE40 Oil (or equivalent) to at least 1/4" over motor windings top plate, or to the top of the stator.

Do not fill the motor housing completely. Allow air space for expansion.

Replace oil pipe plug (3). Recheck with ohmmeter before applying power.

21. Plug the power cord into a grounded outlet and check pump running. Motor should run smoothly and be free of vibration.

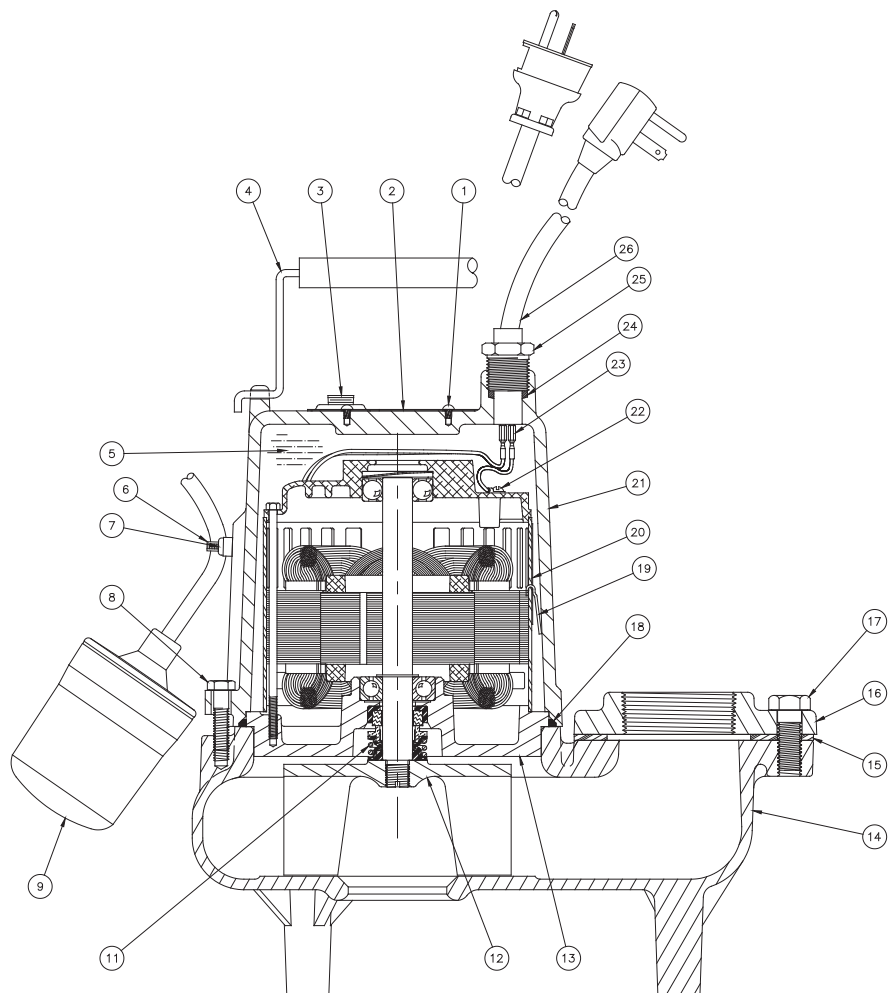

SK50 Parts List

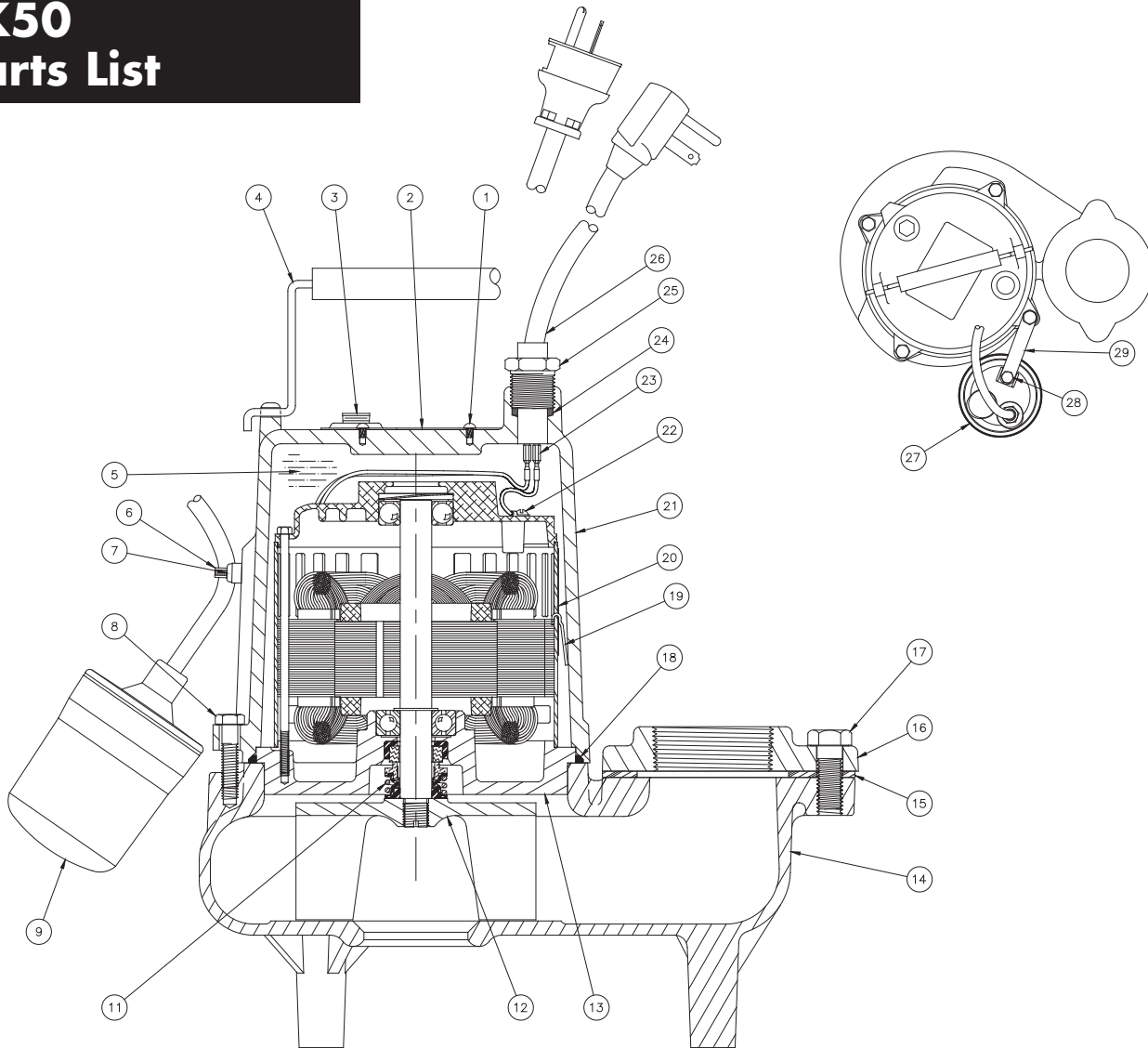

Ref. No.	Part No.	Description	Qty.	Ref. No.	Part No.	Description	Qty.
1	4580-001-1	Drive Screw	2	18	239-007-1	Capscrew (3" Discharge)	2
2	13425-069-1	Nameplate	1	18	77-003-1	O-Ring	1
3	14077-000-1	Pipe Plug	1	19	13666-000-1	Ground Strap	1
4	60-000-5	Handle	1	20	13559-000-1	Motor 115/1/60	1
5	—	Oil-Paraffinic	0.44	20	13593-000-1	Motor 230/1/60	1
6	1055-000-1	Switch Tether	1	21	56-035-1	Motor Housing	1
7	30-002-1	Machine Screw	1	21	14770-001-1	Motor Housing	1
8	101-008-1	Capscrew	4	22	14770-001-1	Ground Screw	1
9	13967-010-1	Wide Angle Piggyback Switch 115V-10' (STD)	1	23	6000-053-1	Wire Terminal 16GA	1
	13967-020-1	Wide Angle Piggyback Switch 115V-20' (OPT)	1	23	6000-061-1	Wire Terminal 16GA	2
	13967-025-1	Wide Angle Piggyback Switch 230V-20' (STD)	1	24	139-014-1	Ring Seal	1
11	14525A010	Shaft Seal	1	25	75-004-1	Cord Nut	1
12	4781-002-2	Impeller	1	26	14623-010-1	Power Cord 16/3 115V-10'	1
13	6846-003-1	Seal Plate	1	26	14623-020-1	Power Cord 16/3 115V-20'	1
14	6818-002-2	Volute	1	26	14623-210-1	Power Cord 16/3 230V-10'	1
15	324-001-1	Gasket	1	26	14623-220-1	Power Cord 16/3 230V-20'	1
16	208-000-2	Discharge Flange 2" (STD)	1	27	14974-009-1	Diaphragm Switch 115V-20' (OPT)	1
	207-000-2	Discharge Flange 3" (OPT)	1	27	14974-010-5	Diaphragm Switch 230V-20' (OPT)	1
17	239-005-1	Capscrew (2" Discharge)	2	28	11455-003-1	Screw	1
				29	5502-005-1	Switch Bracket	1

LIMITED WARRANTY

HYDROMATIC warrants to the original consumer purchaser ("Purchaser" or "You") of HYDROMATIC Sump Pumps, Effluent Pumps, Sewage Pumps (other than 2-1/2"), and Package Systems, that they will be free from defects in material and workmanship for the Warranty Period of 36 months from date of manufacture.

Our warranty will not apply to any product that, in our sole judgement, has been subject to negligence, misapplication, improper installation, or improper maintenance. Without limiting the foregoing, operating a three phase motor with single phase power through a phase converter will void the warranty. Note also that three phase motors must be protected by three-leg, ambient compensated, extra-quick trip overload relays of the recommended size or the warranty is void.

Your only remedy, and HYDROMATIC's only duty, is that HYDROMATIC repair or replace defective products (at HYDROMATIC's choice). You must pay all labor and shipping charges associated with this warranty and must request warranty service through the installing dealer as soon as a problem is discovered. No request for service will be accepted if received after the Warranty Period has expired. This warranty is not transferable.

EXCEPTIONS: Hydromatic Special Application Pumps, Battery Back-Up Sump Pumps, Filtered Effluent Pumps, Grinder Pumps, and 2-1/2" Sewage Pumps are warranted for a period of 12 months from date of purchase or 18 months from date of manufacture, whichever comes first.

HYDROMATIC SHALL NOT BE LIABLE FOR ANY CONSEQUENTIAL, INCIDENTAL, OR CONTINGENT DAMAGES WHATSOEVER.

THE FOREGOING WARRANTIES ARE EXCLUSIVE AND IN LIEU OF ALL OTHER EXPRESS AND IMPLIED WARRANTIES, INCLUDING BUT NOT LIMITED TO THE IMPLIED WARRANTIES OF MERCHANTABILITY AND FITNESS FOR A PARTICULAR PURPOSE. THE FOREGOING WARRANTIES SHALL NOT EXTEND BEYOND THE DURATION EXPRESSLY PROVIDED HEREIN.

Some states do not allow the exclusion or limitation of incidental or consequential damages or limitations on the duration of an implied warranty, so the above limitations or exclusions may not apply to You. This warranty gives You specific legal rights and You may also have other rights which vary from state to state.

This warranty supersedes and replaces all previous warranty publications.

HYDROMATIC

740 East 9th Street, Ashland, OH 44805

Phone: 888-957-8677 • Fax: 888-840-7867 • Web Site: <http://www.hydromatic.com>



HYDROMATIC®

Pentair Water

USA

740 East 9th Street, Ashland, Ohio 44805

Tel: 888-957-8677 Fax: 888-840-7867



www.hydromatic.com

– Your Authorized Local Distributor –

CANADA

269 Trillium Drive, Kitchener, Ontario, Canada N2G 4W5

Tel: 519-896-2163 Fax: 519-896-6337