

Performance Data

SPX50/SPX50H

Wholesale Products Page: 6800-1

Section: Performance Data

Dated: October 2007

SPX50	RPM: 1750	Discharge: 2"	Solids: 2"
SPX50H	RPM: 1750	Discharge: 1½"	Solids: ¾"

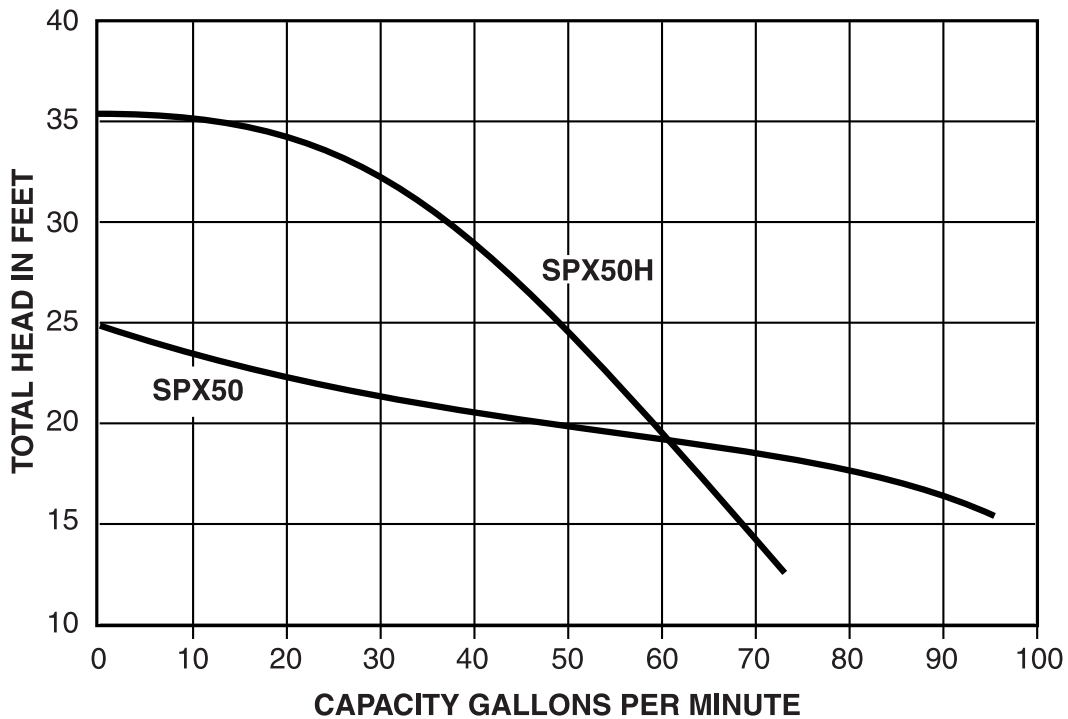
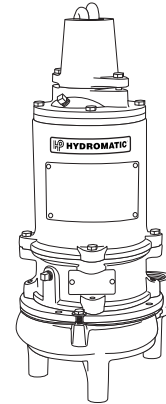

The curves reflect maximum performance characteristics without exceeding full load (Nameplate) horsepower. All pumps have a service factor of 1.2. Operation is recommended in the bounded area with operational point within the curve limit. Performance curves are based on actual tests with clear water at 70° F. and 1280 feet site elevation.

Conditions of Service:

GPM: _____ TDH: _____



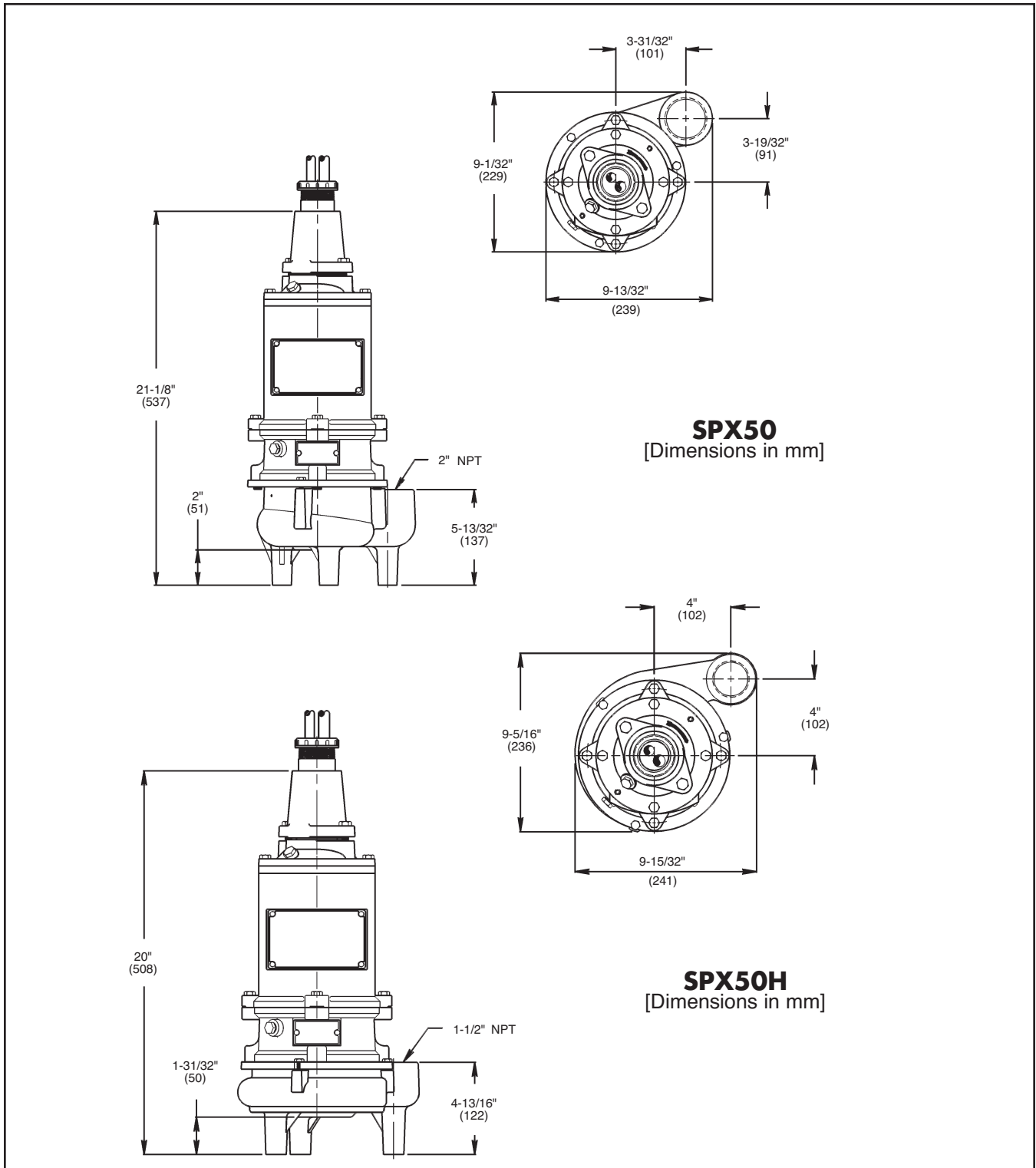

All dimensions in inches. Metric for international use. Component dimensions may vary $\pm 1/8$ inch. Dimensional data not for construction purpose unless certified. Dimensions and weights are approximate. On/Off level adjustable. We reserve the right to make revisions to our product (s) and the product (s) specifications without notice.

MODEL: SPX50, Explosion-Proof Sump Pumps

R.P.M.	1750
MOTOR TYPE	OIL COOLED INDUCTION, CAPACITOR START
MOTOR DESIGN NEMA TYPE	TYPE N
GENERAL INSULATION CLASS	B
MAXIMUM STATOR TEMPERATURE	266°F (130°C)
MOTOR PROTECTION	WINDING HEAT SENSORS

HP	VOLTAGE	PHASE	NEC CODE	SERVICE FACTOR	FULL LOAD AMPS
1/2	200/230	1	-	1	5.9/5.3

MODEL: SPX50H, Explosion-Proof Sump Pumps

R.P.M.	1750
MOTOR TYPE	OIL COOLED INDUCTION, CAPACITOR START
MOTOR DESIGN NEMA TYPE	TYPE N
GENERAL INSULATION CLASS	B
MAXIMUM STATOR TEMPERATURE	266°F (130°C)
MOTOR PROTECTION	WINDING HEAT SENSORS

HP	VOLTAGE	PHASE	NEC CODE	SERVICE FACTOR	FULL LOAD AMPS
1/2	200/230	1	-	1	5.9/5.3

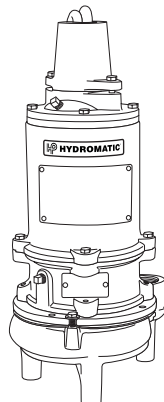

MODEL: SPX50/SPX50H, Explosion-Proof Sump Pumps**Physical Data:**

DISCHARGE SIZE	2" NPT (SPX50) 1½" NPT (SPX50H)
SOLIDS SIZE	2" (SPX50) ¾" (SPX50H)
IMPELLER TYPE	RECESSES
CABLE LENGTH	20' STANDARD
PAINT	

Temperature:

MAXIMUM LIQUID	140°F
MAXIMUM STATOR	266°F (130°C)
OIL FLASH POINT	390°F

Technical Data:

POWER CORD TYPE	SOW / SOW-A	
MATERIALS OF CONSTRUCTION	MOTOR HOUSING	CAST IRON
	CASING	CAST IRON
	IMPELLER	CAST IRON
	MOTOR SHAFT	416 STAINLESS STEEL
	HARDWARE	316 STAINLESS STEEL
	"O" RINGS	
MECHANICAL SEALS Standard:	CARBON / CERAMIC	
UPPER BEARING	BALL RADIAL 6203	
LOWER BEARING	BALL - THRUST 6306	

MODELS: SPX50/SPX50H, EXPLOSION PROOF Sewage Ejector**1.01 GENERAL**

Contractor shall furnish all labor, materials, equipment and incidentals required to provide (Qty.) submersible centrifugal sewage pump(s) as specified herein. The pump models covered in this specification are the SPX50/SPX50H. The pump furnished for this application shall be MODEL _____ as manufactured by Hydromatic Pumps.

2.01 DESIGN CONDITIONS

Each pump shall be rated _____ H.P., _____ volts, _____ phase, _____ hertz and operate at _____ RPM.

3.01 OPERATING CONDITIONS

The pump shall deliver _____ U.S. GPM/LPS at _____ feet/meters TDH, and handle a _____ inch solid. The curve submitted for approval shall state, in addition to head and capacity performance, solid handling capability, amp rating, and design impeller diameter.

4.01 CONSTRUCTION

Each pump shall be of the sealed submersible type, incorporating features normally found in pumps furnished for the residential market.

These features include:

1. The seal housing for the SPX50/SPX50H is corrosion resistant cast iron.
2. The pump inlet shall be open and clear, without screening to provide access for sewage and solids.
3. All external mating parts shall be machined and Buna N, O-Ring sealed.
4. All fasteners exposed to the pumped liquid shall be 300 series stainless steel.
5. All power cords shall be water resistant UL or CSA approved, with double insulation, and sized as a function of Amp. draw.

5.01 MOTOR AND SHAFT

The stator, rotor and bearings shall be mounted in a sealed submersible type housing. Single phase motors shall be split phase or capacitor start with centrifugal switch. Three phase motors shall be Polyphase. Full Load and Locked Rotor Amps as well as Start and Run winding resistance shall be tabulated for each pump.

6.01 BEARINGS, SHAFT AND MECHANICAL SEAL

An upper radial and lower thrust bearing shall be required. These shall be heavy duty single row ball bearings which are permanently and continuously lubricated and cooled by the dielectric oil which fills the motor housing. The motor shaft shall be stainless steel and sealed from the pumped liquid with a carbon ceramic mechanical seal.

7.01 IMPELLER

The Impeller shall be high capacity, two vane, non-clog design with pump out vanes on the back side. These vanes wash out grit and stringy material that will damage the shaft and mechanical seal.

8.01 AUTOMATIC CONTROL

All single phase pumps should be capable of automatic operation.

9.01 MANUAL CONTROL

The Single Phase pumps are not supplied with any type of automatic control. A super or double wide angle piggy-back float switch can be supplied and fitted to these pumps.

10.01 PAINTING

All cast iron parts shall be painted before assembly with a water reducible alkyd air dried enamel. The paint shall be applied in one coat with a minimum thickness of 3 to 4 mils.

11.01 TESTING

All pumps shall be individually tested to include the following:

1. The pump and power cord shall be visually inspected for imperfections, cuts or nicks.
2. The pump shall have a ground continuity check and the motor chamber shall be Hi-potted to test for moisture content and/or insulation defects.
3. The motor and volute housing shall be pressurized and a 10 second air leak decay test run.
4. Oil is added, and the pump is run. Voltage and current are monitored visually, electronically, and the tester listens for any noise or malfunction.