

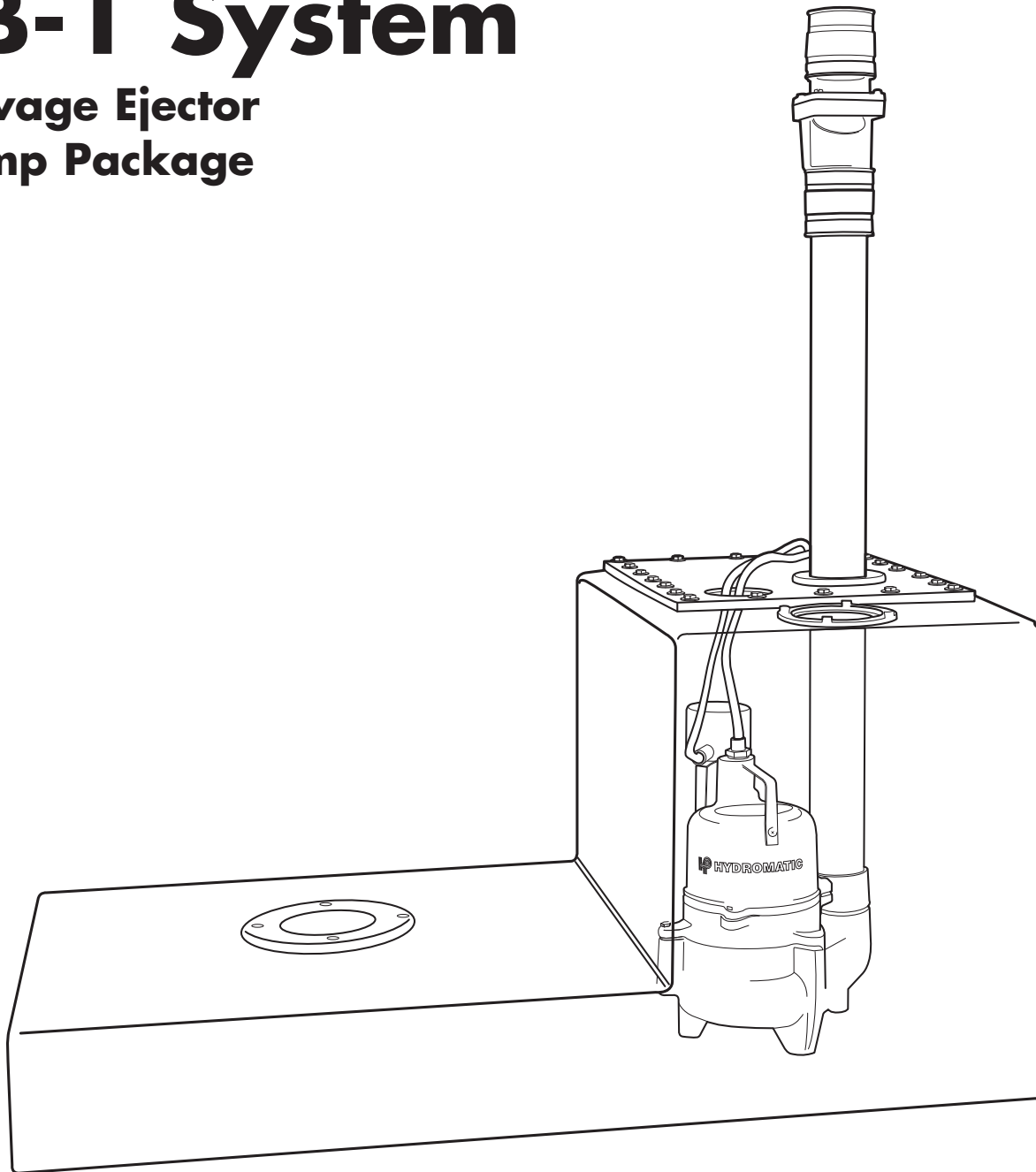

# HYDROMATIC®

## JB-1 System

Sewage Ejector  
Pump Package



NOTE! To the installer: Please make sure you provide this manual to the owner of the pumping equipment or to the responsible party who maintains the system.



**Pentair**  
**Water™**

## General Information

Thank you for purchasing your Hydromatic® pump. To help ensure years of trouble-free operation, please read the following manual carefully.

### Before Operation:

Read the following instructions carefully. Reasonable care and safe methods should be practiced. Check local codes and requirements before installation.

### Attention:

This manual contains important information for the safe use of this product. Read this manual completely before using this product and refer to it often for continued safe product use. **DO NOT THROW AWAY OR LOSE THIS MANUAL.** Keep it in a safe place so that you may refer to it often.

### Warning:

Before handling these pumps and controls, always disconnect the power first. Do not smoke or use sparkable electrical devices or flames in a septic (gaseous) or possible septic sump.

## Pump Warning

**WARNING: Risk of Electrical Shock — for your protection always disconnect pump from the power source before handling. If the pump is wired direct, disconnect power to the control box. Grounded pumps are supplied with a 3-prong grounded plug to help protect**

**you against the possibility of electrical shock. Do not remove the ground pin from the plug. To reduce the risk of electrical shock, a properly grounded receptacle or control box of grounding type must be installed and protected by a ground fault circuit interrupter (GFCI) in accordance with national electrical code and applicable local codes.**

**WARNING: Do not smoke or use sparkable electrical devices or flame in a septic (gaseous) or possible septic atmosphere.**

1. Inspect all materials before accepting them. If the damage is apparent on the outside of the box, claims for damages should be filed with the shipper. Hidden damage can occur during shipment. If the unit is found to be damaged after opening the box, contact your local Hydromatic distributor before using.
2. Before installation or operation carefully read all the information provided with this product. Familiarize yourself with specific details regarding installation and use before attempting the installation.
3. Make certain that the ground fault interrupter protected receptacle or control box is within reach of the pump's power cord. Use of extension cords that are too long or too light do not deliver sufficient voltage to the pump motor. They could also present a safety hazard if the insulation were to become damaged or the connection end were to fall into a damp or wet area.
4. Check to be sure your power source is adequate to handle the amperage requirements of the motor as indicated on the pump, and that the voltage matches that indicated on the pump. Make sure the pump's electrical supply circuit is

equipped with a separate 15 amp circuit breaker according to the National Electrical Code.

5. **Testing for Ground.** As a safety measure, each electrical outlet should be checked for ground. If the system is not properly grounded or you are not sure, call a licensed electrician for assistance.

**CAUTION: All plumbing must be installed to meet local codes. The unit must be vented.**

**CAUTION: Installation and checking of all electrical circuits and hardware should be performed only by a qualified licensed electrician.**

**CAUTION: Repair and service should be performed by an authorized Hydromatic service station only.**

**CAUTION: Refer to the appropriate manual for operation and maintenance of the pump that is provided with this system.**

**NOTE: Use extreme caution around electrical devices. Electrical shock may occur.**

**NOTE: See the performance curve for this unit on page 7 of this manual. This pumping unit is designed to discharge sewage up to a maximum of 18 feet total dynamic head (T.D.H.) including friction loss of pipe and fittings. This unit should not be used with systems requiring total dynamic heads above 18 feet.**

**NOTE: Do not use wax seal having flange that extends into tank; it may cause clogging. If a floor is installed over the tank, use toilet manufacturer designed floor flange extender seal kit.**

Failure to heed above cautions could result in injury or death.

## Pump System Installation

The JB-1 is designed as a relatively easy project provided the installation instructions are followed and national or local electrical and plumbing codes are followed. Bathrooms are usually small. Because so many activities occur in such a small place, thorough planning is a must. Get the right tools for the job before beginning, and make a specific and thorough plan. You may need to make drawings, obtain a building permit and/or have your work inspected. Be prepared; read all instructions that come with this product before installation.

### Basic Tools for the Job:

(Some of these tools may not be needed depending on the type of installation chosen)

- Adjustable wrench
- Wallboard knife
- Clamps
- Ratchet wrench
- Flat pry bar
- Sponge
- Hammer
- Wrecking bar
- Multi-meter
- Masonry hammer
- Hacksaw
- Paint brush
- Wood chisel
- Screwdrivers
- Carpenter's level
- Masonry chisel
- Tape measure
- Expandable plumber's plug
- Putty knife
- Marker
- Cloths, rags
- Notched trowel
- Staple gun
- Neon circuit tester

1. The JB-1 can be installed as a free standing unit or can be enclosed.
2. Maintain at least 6" between major bathroom fixtures.
3. If installing a shower or bathtub, do not install them within 60" of any light switch.

**NOTE: The above recommendations meet or exceed national and most local building codes, and are meant only as recommendations when installing the JB-1 alone or as part of a complete bathroom.**

1. Position tank at desired location that is level within 1/8" for the length. Ensure that nails, screws, or other sharp objects do not puncture the tank.
2. For an enclosed installation the unit is designed to fit within a 2" x 6" floor joist.

**NOTE: A floor flange extender seal kit must be used for this type of installation, and is not included with the JB-1 system.**

3. Determine the location for the JB system with attention given to access to the discharge and vent lines. Make the necessary measurements, and determine the necessary fittings and piping that are required. Be sure to observe all local plumbing codes.
4. Install the long bolts and nuts (Fig. 3, Item 3) that are used to fasten the toilet to the tank or subfloor.

**NOTE: A standard floor flange is not required.**

The position of the toilet must be determined to allow the longer bolts to be inserted in the correct holes. Install the wax ring making sure to align closet bolts for installation of the toilet bowl in the desired direction. (i.e., If the vent and discharge pipe is to be installed behind the wall, the toilet

bowl/flush tank will be parallel to the pump housing and piping.)

5. Set pump in pump housing with discharge toward the right back corner as viewed from toilet opening. The vertical float switch must line up square in the middle of the corner baffle located inside the pump chamber. Shim pump as required.
6. Apply foam gasket (Fig. 3, Item 6) to flange of pump chamber. For best results, overlap ends or gasket approximately 1/2".
7. Place 2" straight flange in 2-3/8" hole; this is the discharge.
8. Install the discharge pipe (approximately 18" in length) in lid as follows. Lubricate the 2" rubber seal with soapy water and push the 2" pipe through the seal.
9. Install the lid on the tank as follows. Push the 2" discharge pipe down until approximately 1-1/2" is protruding through the lid. Pull pump power cord up out of the tank and hang over edge of the pump housing. Screw threaded adapter into the pump discharge by rotating the lid assembly until hand tight. Feed end of pump power cord and the cord seal through small hole in cover in the lid. (Fig. 3, Item 8) Push lid down into position on the pump well. Tighten pump 2" discharge pipe with a strap wrench. Do not press cord seal into lid at this time. (Ref. Step 21) Bolt lid in place with (20) 1/4"-20 bolts and washers provided. (Fig. 3, Items 1, 2)
10. Install the threaded vent pipe or glue the vent pipe to a male adapter.

11. The discharge pipe should protrude approximately 4" above the surface of the lid. Attach the check valve (Fig. 3, Item 4) to the discharge pipe with the arrow on the check valve body, indicating flow, pointing away from the pump.
12. Connect 2" discharge pipe and 2" vent pipe into house plumbing.

**CAUTION: The unit must be vented according to local codes. Toilet will not flush unless properly vented.**

13. If additional fixture(s) are being added to your installation, a 2" rubber pipe seal must be inserted in the tank. Refer to Fig. 1 for location.

**NOTE: The bottom of the additional fixture, a 3" diameter hole, must be 5" minimum above the base of the tank, as shown in Fig. 1.**

14. Drill 3" diameter hole at the desired location on one of the four sides of the pump chamber surface. The center line of the hole must be a minimum of 1" above the tank top surface if one of the sides is chosen for the flange mounting.
15. After choosing the spot for the hole, lightly center punch hole centers on pump chamber.
16. Drill a 3" diameter hole with a hole saw for mounting the 2" rubber pipe seal to the tank.

**WARNING: Hole diameter must not be oversized or the tank may leak. The hole should be no bigger than 3.05".**

17. Lubricate 2" rubber pipe seal with soapy water and push it into 3" drilled hole. Lubricate fixture drain pipe and push through the 2" rubber pipe seal into the pump chamber. Pipe must not interfere with the operation of or touch the pump.
18. Test the pump by partially filling the tank to a depth of approximately 4". This can be checked with the tape measure through the opening where toilet is to be installed. Plug in the pump. The pump will turn on before the water level reaches 4-1/2".

**CAUTION: Unplug the pump before adjusting the switch. If the pump does not turn on before 4-1/2", slide the upper rubber "stop" down the float rod and retest. If the pump starts before 3-1/4", slide the upper "stop" to a higher point on the float rod and retest. The pump must turn on between 3-1/4" and 4-1/2".**

19. Check the tank for leaks. Attach the cord to the discharge or vent pipe. Do not leave an excess length of cord inside tank. It may interfere with the proper operation of the pump.
20. Test the tank discharge pipe and vent pipe with 10 feet water column if required by local code. Plug the 4" diameter opening in the tank with an expandable plumbers plug. Make certain the tank lid screws are torqued down properly. The system can now be tested per code requirements.

**WARNING: The tank and lid will expand with the water column pressure while tested. If the tank is to be installed under the floor, the testing should be completed before the floor is installed.**

21. Install wax toilet bowl seals at hole and install toilet in place following the instructions from the wax seal package.

**NOTE: Do not use wax seal having flange that extends into tank; it may cause clogging. If a 1/2" or 1/4" floor is installed over the tank, the appropriate floor flange extender seal kit must be used. See item 3 in the installation instructions.**

22. Hook up water line to toilet. Turn on water and fill tank. Test for leaks, flush toilet and allow pump to cycle to ensure proper operation.

# Pump Warning

**END VIEW**

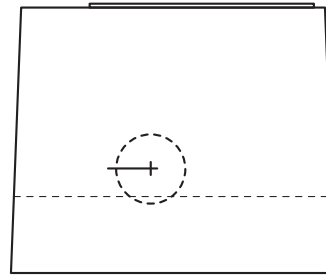

**SIDE VIEW**

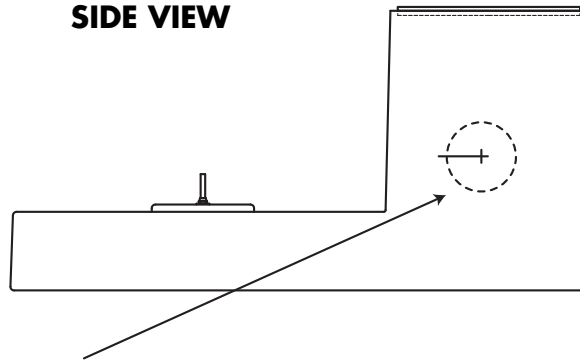

**Figure 1**

**NOTE:** The bottom of the additional fixture 3" diameter hole must be 5" minimum above the base of the tank as shown. Cut out spotting template below. Pipe installed in this 2" seal must be supported vertically.

**NOTE:** The 3" hole cut in the tank should not be bigger than 3.05" in diameter to prevent leaking.

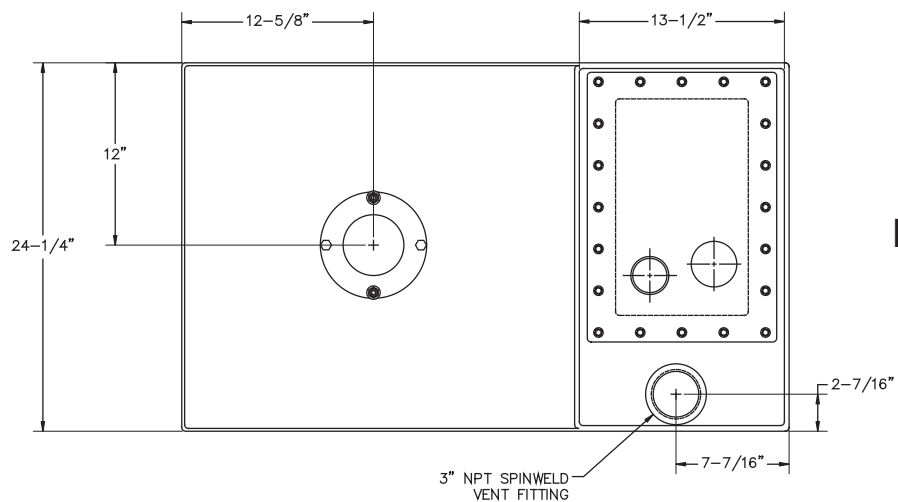

**Figure 2**

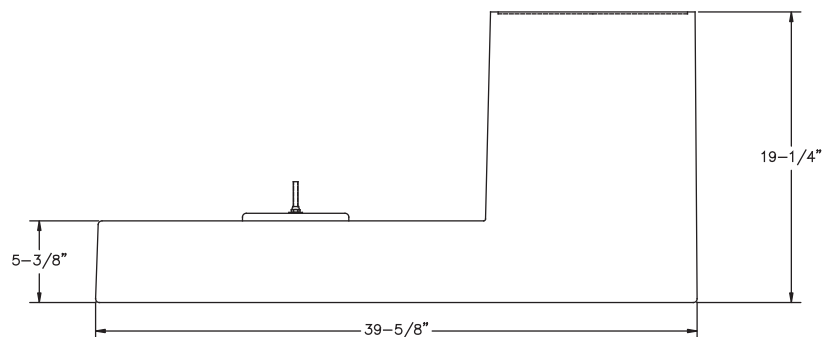

# Pump Troubleshooting

Troubleshooting information for pump only. For other questions or problems, please contact your authorized Hydromatic service center.

Servicing should be performed only by an authorized Hydromatic service center.

**WARNING: Always disconnect the pump from power source before handling or making any adjustments. Always wear rubber boots when there is water on the floor and you must unplug the pump or make any adjustments.**

**NOTE: Automatic thermal overload protects the sealed-in-oil motor. Running dry may overheat the motor and activate the overload protector until the motor cools.**

**Pump does not run or just hums.**

1. Line circuit breaker may be off, blown or loose.
2. Water level in sump may be too low to activate automatic float.
3. Power cord plug may not be making contact in receptacle.
4. If all symptoms check OK, motor winding may be open; take to authorized service center or distributor for check.

**Pump runs but does not deliver water, or small amount of water.**

1. Check valve may be installed backward. Arrow on valve points in direction of flow.

2. Discharge gate valve, if used, may be closed.
3. Pump may be air locked. Start and stop several times by plugging and unplugging cord. Check vent hole in pump case for plugging.

Hydromatic pumps have a small air vent hole in the impeller cavity to let out trapped air. If this hole becomes plugged, pump may air lock. To break the air lock, use a small screwdriver to clear hole in the impeller cavity.

As a secondary precaution in installations of this type — 1/16" hole should be drilled in the discharge pipe below the check valve. The check valve should be 12 to 18 inches above pump discharge. Do not put check valve directly into pump discharge opening.

**NOTE: In sumps where the pump is operating daily, air locking rarely occurs.**

4. Pump head may be too high. Pump cannot deliver water over 21.0' vertical lift. Horizontal distance does not affect pumping, except for friction loss through the pipe.
5. Inlet in pump base may be clogged. Remove pump and clean out openings.
6. Impeller or volute openings may be plugged or partially plugged. Remove pump and clean out.
7. Pump impeller may be partially clogged causing motor to run slow, resulting in motor overload. Clear impeller.

**Fuse blows or circuit breaker trips when pump starts.**

1. Inlet in pump base may be clogged. Remove pump and clean out openings.
2. Impeller or volute openings may be plugged or partially plugged. Remove pump and clean out.
3. Pump impeller may be partially clogged causing motor to run slow, resulting in motor overload. Clear impeller.
4. Fuse size or circuit breaker is too small.
5. Defective motor stator: return to authorized Hydromatic service center or distributor for verification.

**Motor runs for short time then stops. Then after short period starts again. Indicates tripping overload caused by symptom shown.**

1. Inlet in pump base may be clogged. Remove pump and clean out openings.
2. Impeller or volute openings may be plugged or partially plugged. Remove pump and clean out.
3. Pump impeller may be partially clogged causing motor to run slow, resulting in motor overload. Clear impeller.
4. Defective motor stator; return to authorized Hydromatic service center or distributor.

# JB-1 System Parts List

**Figure 3—  
Installation Hardware Kit**

Item	Description	Qty.
1	1/4"-20 x 5/8" Hex Head Bolts	20
2	Flat Washers—.320 I.D.	20
3	5/16" x 2" Stud and Nuts	2
4	Check Valve	1
5	Wax Ring (Retail Boxed)	1
6	1/2" Foam Gasket Material	1
7	2" Adapt-A-Flex Pipe Grommet	2
8	Adapt-A-Flex Pipe Grommet for Cords	1
9	2" x 32" Long Schedule 40 PVC, with 2" NPT Male Adapter	1

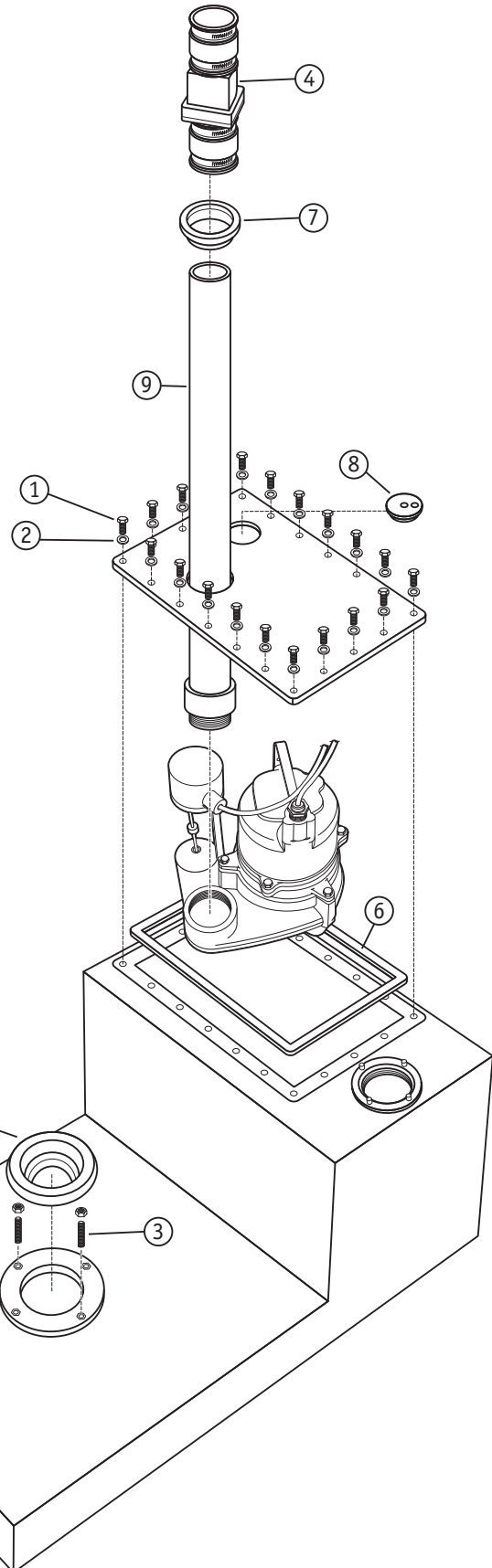

**SKV40 CURVE**

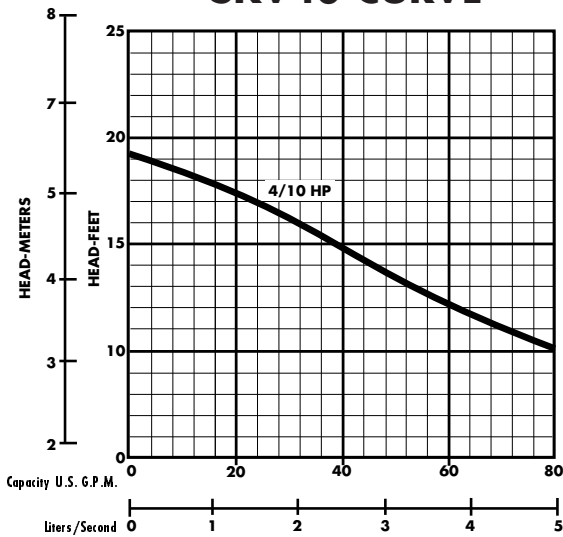

## LIMITED WARRANTY

HYDROMATIC warrants to the original consumer purchaser ("Purchaser" or "You") of HYDROMATIC Sump Pumps, Effluent Pumps, Sewage Pumps (other than 2-1/2"), and Package Systems, that they will be free from defects in material and workmanship for the Warranty Period of 36 months from date of manufacture.

Our warranty will not apply to any product that, in our sole judgement, has been subject to negligence, misapplication, improper installation, or improper maintenance. Without limiting the foregoing, operating a three phase motor with single phase power through a phase converter will void the warranty. Note also that three phase motors must be protected by three-leg, ambient compensated, extra-quick trip overload relays of the recommended size or the warranty is void.

Your only remedy, and HYDROMATIC's only duty, is that HYDROMATIC repair or replace defective products (at HYDROMATIC's choice). You must pay all labor and shipping charges associated with this warranty and must request warranty service through the installing dealer as soon as a problem is discovered. No request for service will be accepted if received after the Warranty Period has expired. This warranty is not transferable.

EXCEPTIONS: Hydromatic Special Application Pumps, Battery Back-Up Sump Pumps, Filtered Effluent Pumps, Grinder Pumps, and 2-1/2" Sewage Pumps are warranted for a period of 12 months from date of purchase or 18 months from date of manufacture, whichever comes first.

HYDROMATIC SHALL NOT BE LIABLE FOR ANY CONSEQUENTIAL, INCIDENTAL, OR CONTINGENT DAMAGES WHATSOEVER.

THE FOREGOING WARRANTIES ARE EXCLUSIVE AND IN LIEU OF ALL OTHER EXPRESS AND IMPLIED WARRANTIES, INCLUDING BUT NOT LIMITED TO THE IMPLIED WARRANTIES OF MERCHANTABILITY AND FITNESS FOR A PARTICULAR PURPOSE. THE FOREGOING WARRANTIES SHALL NOT EXTEND BEYOND THE DURATION EXPRESSLY PROVIDED HEREIN.

Some states do not allow the exclusion or limitation of incidental or consequential damages or limitations on the duration of an implied warranty, so the above limitations or exclusions may not apply to You. This warranty gives You specific legal rights and You may also have other rights which vary from state to state.

This warranty supersedes and replaces all previous warranty publications.

### HYDROMATIC

740 East 9th Street, Ashland, OH 44805

Phone: 888-957-8677 • Fax: 888-840-7867 • Web Site: <http://www.hydromatic.com>

– Your Authorized Local Distributor –



**HYDROMATIC®**

Pentair Water

#### USA

740 East 9th Street, Ashland, Ohio 44805

Tel: 888-957-8677 Fax: 888-840-7867

[www.hydromatic.com](http://www.hydromatic.com)

#### CANADA

269 Trillium Drive, Kitchener, Ontario, Canada N2G 4W5

Tel: 519-896-2163 Fax: 519-896-6337