

Performance Data

SD/SW/VS33

Wholesale Products Page: 6390-1

Section: Performance Data

Dated: October 2002

RPM: **1550**

Discharge: **1-1/2"** Solids: **1/2"**

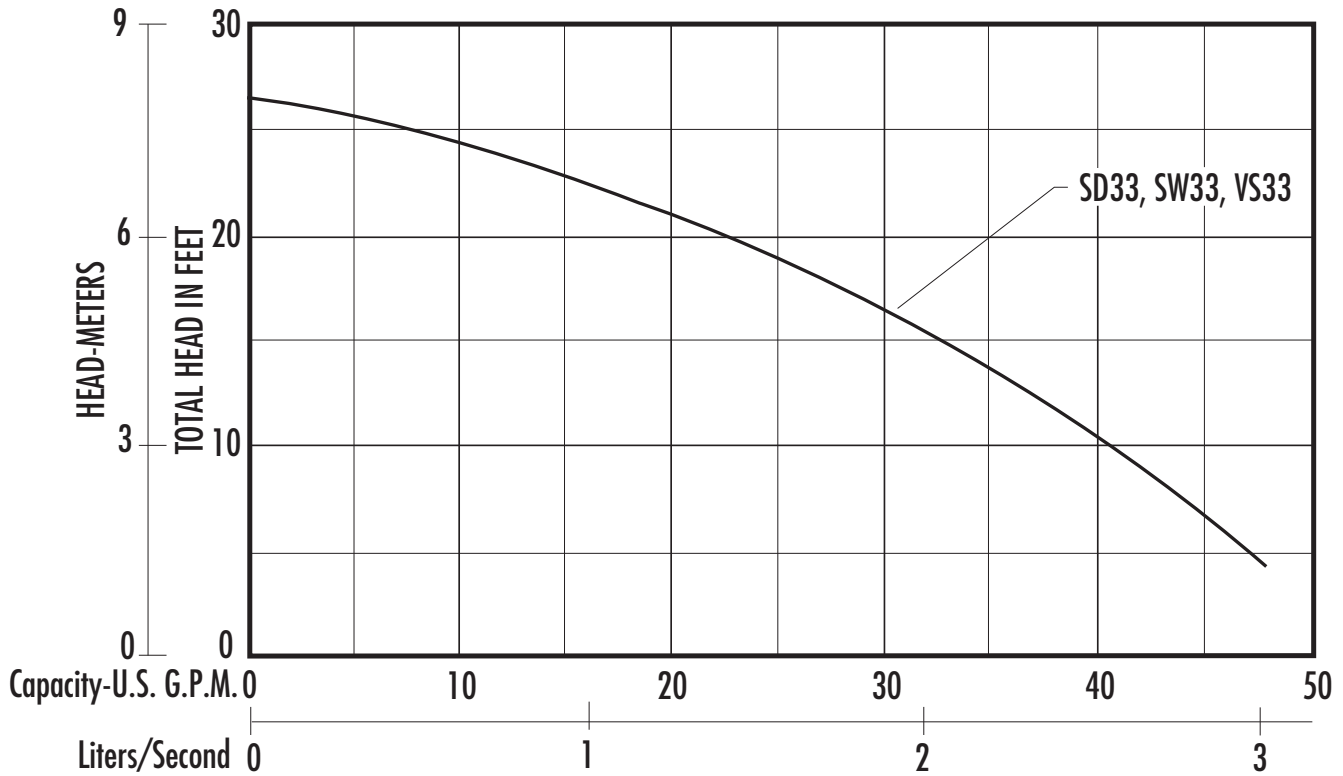
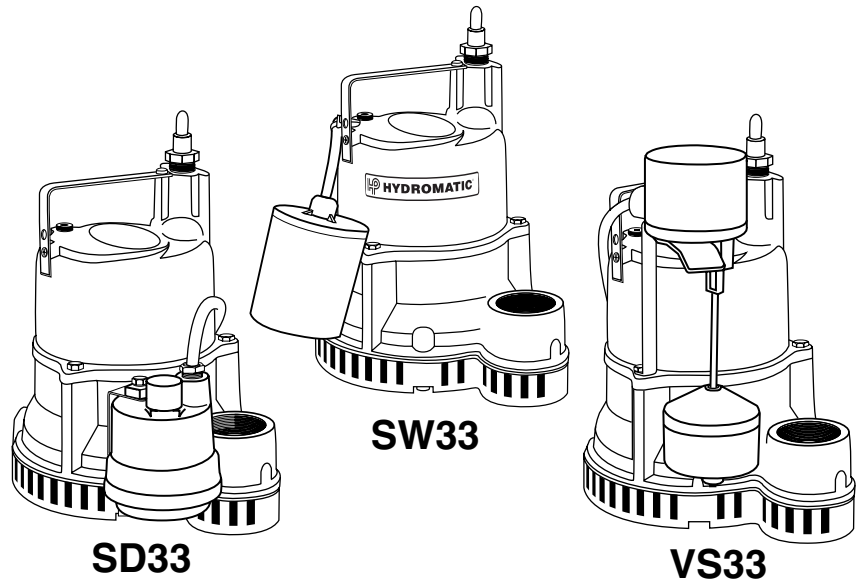

The curves reflect maximum performance characteristics without exceeding full load (Nameplate) horsepower. All pumps have a service factor of 1.2. Operation is recommended in the bounded area with operational point within the curve limit. Performance curves are based on actual tests with clear water at 70° F. and 1280 feet site elevation.

Conditions of Service:

GPM: _____ TDH: _____



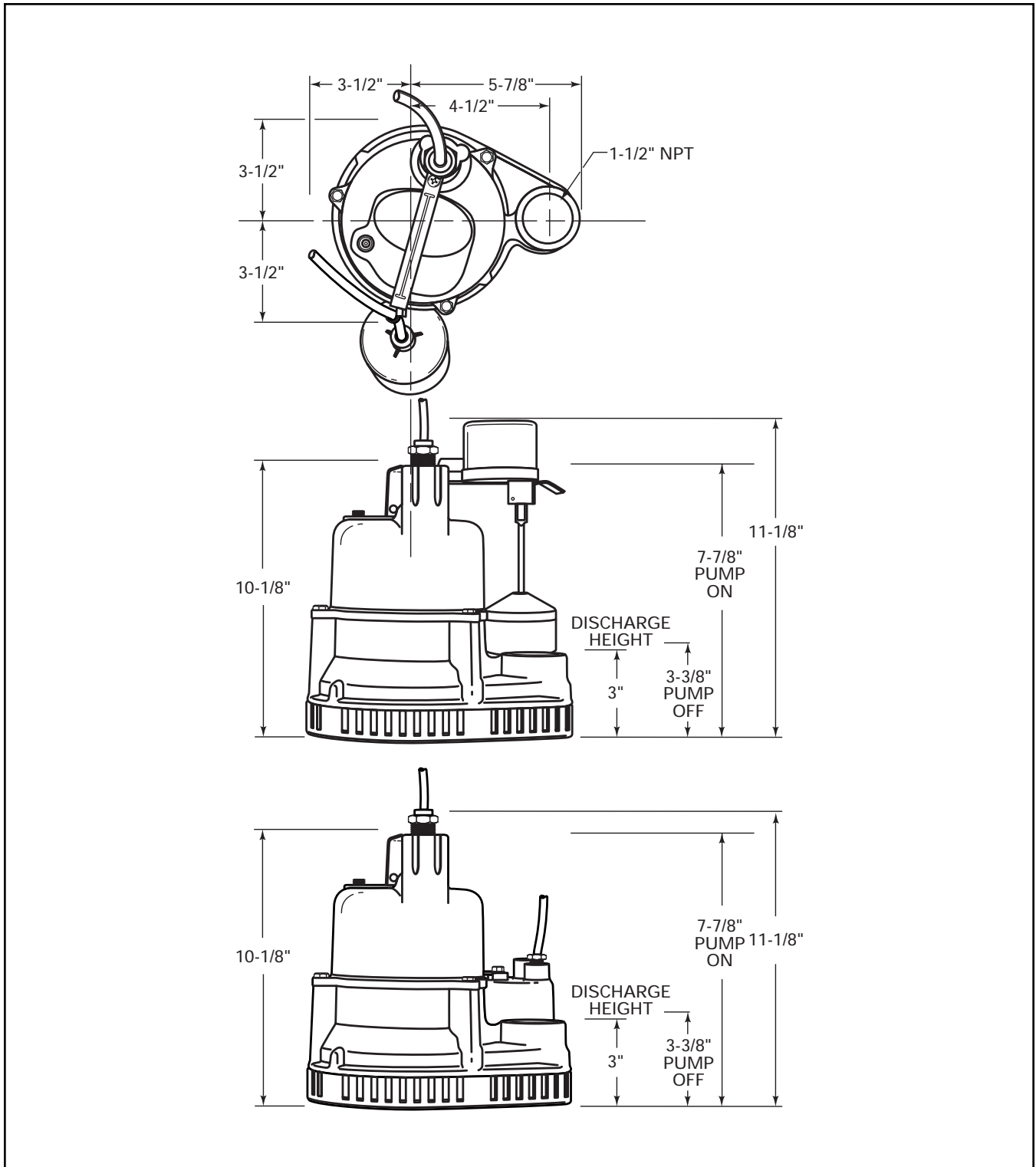

All dimensions in inches. Metric for international use. Component dimensions may vary $\pm 1/8$ inch. Dimensional data not for construction purpose unless certified. Dimensions and weights are approximate. On/Off level adjustable. We reserve the right to make revisions to our product (s) and the product (s) specifications without notice.

MODEL: SW/SD/VS33, Sump/Effluent

R.P.M.	1550
MOTOR TYPE	SHADED POLE WITH THERMAL OVERLOAD, OIL FILLED
MOTOR PROTECTION	AUTOMATIC RESET / OVERLOAD PROTECTED

HP	VOLTAGE	PHASE	NEC CODE	SERVICE FACTOR	FULL LOAD AMPS
1/3	115	1	-	1	10.0

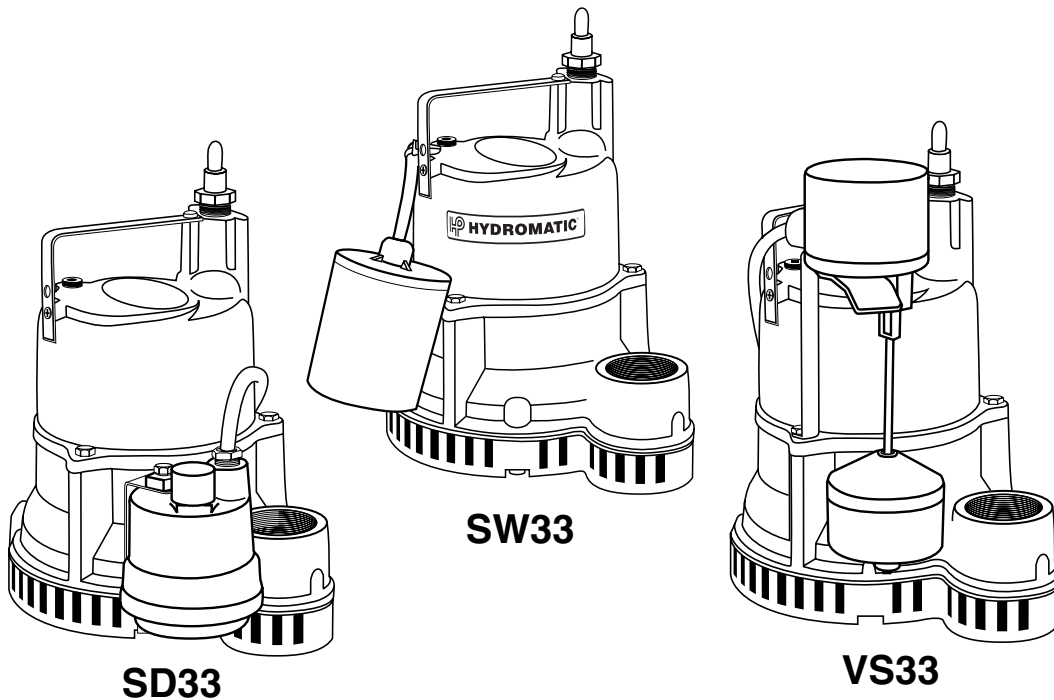

MODEL: SD/SW/VS33, Sump/Effluent**Physical Data:**

DISCHARGE SIZE	1-1/2" NPT
SOLIDS SIZE	1/2"
IMPELLER TYPE	VORTEX
CABLE LENGTH	10' STANDARD 20' OPTIONAL
PAINT	PAINTED DARK GREEN, WATER REDUCIBLE ENAMEL, ONE COAT, AIR DRIED.

Temperature:

MAXIMUM LIQUID	140°
MAXIMUM STATOR	-
OIL FLASH POINT	-

Technical Data:

POWER CORD TYPE	SJTW	
MATERIALS OF CONSTRUCTION	MOTOR HOUSING	CAST IRON
	CASING	CAST IRON
	IMPELLER	THERMOPLASTIC
	MOTOR SHAFT	STEEL
	HARDWARE	STAINLESS STEEL
	"O" RINGS	BUNA - N
MECHANICAL SEALS Standard:	CARBON / CERAMIC	
UPPER BEARING	N/A	
LOWER BEARING	SINGLE ROW-BALL	

SUBMERSIBLE SUMP/EFFLUENT MODELS: VS33, SW33, and SD33

1.01 GENERAL

Contractor shall furnish all labor, materials, equipment and incidentals required to provide _____ (Qty.) submersible centrifugal sump/effluent pump(s) as specified herein. The pump models covered in this specification are the VS33, SW33, and SD33. The pump furnished for this application shall be MODEL _____ as manufactured by Hydromatic Pumps.

2.01 DESIGN CONDITIONS

Each pump shall be rated _____ H.P., _____ volts, _____ phase, _____ hertz and operate at _____ RPM.

3.01 OPERATING CONDITIONS

The pump shall deliver _____ U.S. GPM/LPS at feet/meters TDK, and handle a _____ inch solid. The curve submitted for approval shall state, in addition to head and capacity performance, solid handling capability, amp rating, and design impeller diameter.

4.01 CONSTRUCTION

Each pump shall be of the sealed submersible type incorporating features normally found in pumps furnished for the residential market.

These features include:

1. The pump volute and motor housing shall be high quality gray cast iron, ASTM A-48, Class 30.
2. The pump shall feature a multiple strainer inlet that prevents clogging from foreign objects and provides optimum operation and reduced maintenance.
3. All external mating parts shall be machined and Buna N, O-Ring sealed.
4. All fasteners exposed to the pumped liquid shall be 300 series stainless steel.
5. All power cords shall be water resistant UL or CSA approved, with double insulation and sized as a function of Amp. draw.

5.01 MOTOR AND SHAFT

The stator, rotor and bearings shall be mounted in a sealed submersible type housing. Single phase motors shall be Shaded Pole, with automatic reset thermal overload protection. Full Load and, Locked Rotor Amps as well as Run winding resistance shall be tabulated for each pump.

6.01 BEARINGS, SHAFT AND MECHANICAL SEAL

An upper bushing bearing and lower thrust bearing shall be required. The upper bearing shall be brass (VS, SD and SW) while the lower bearing is heavy duty single row ball. They are both permanently, continuously lubricated and cooled by the dielectric oil, which fills the motor housing. The motor shaft shall be corrosion resistant steel and sealed from the pumped liquid with a carbon ceramic mechanical seal.

7.01 IMPELLER

The Impeller shall be a thermoplastic, eight vane, vortex design with three pump out vanes on the back side. These vanes wash out grit and stringy material that will damage the shaft and mechanical seal.

8.01 AUTOMATIC CONTROL

All pumps should be capable of automatic operation.

9.01 PRESSURE SWITCH

The SD33 Single Phase pump is furnished with a pressure diaphragm switch that is UL listed for water and sewage and GSA certified. The diaphragm switch cord shall be fitted with a piggy-back plug that allows the pump to be operated manually without removal from the sump.

10.01 FLOAT SWITCH

The SW33 Single Phase pump is supplied with a tilt-sensitive wide-angle float switch which is sealed in a non-corrosive PVC enclosure. The switch is UL listed for water and sewage and QSA certified. The float switch shall also be fitted with a piggy-back plug that allows the pump to be operated manually without removal from the sump.

11.01 VERTICAL MECHANICAL SWITCH

The VS33 single phase pump is furnished with a magnetic mechanical switch which is sealed in a non-corrosive PVC enclosure. The switch will be activated by a PVC float sliding up and down a non-corrosive rod. The mechanical switch cord shall also be fitted with a piggy-back plug that allows the pump to be operated manually without removal from the sump.

12.01 PAINTING

All cast iron parts shall be painted before assembly with a water reducible alkyd air dried enamel. The paint shall be applied in one coat with a minimum thickness of 3 to 4 mils.

13.01 TESTING

All pumps shall be individually tested to include the following:

1. The pump and power cord shall be visually inspected for imperfections, cuts or nicks.
2. The pump shall have a ground continuity check and the motor chamber shall be Hi-potted to test for moisture content and/or insulation defects.
3. The motor and volute housing shall be pressurized and a 10 second air leak decay test run.
4. A specific amount of oil is now added. The pump is run in a fully automated, sequenced, control console, which monitors voltage, current and watts visually and electronically. The tester listens for any noise or malfunction.