

Performance Data

A+

Wholesale Products Page: 6820-1

Section: Performance Data

Dated: January 2001

RPM: **3450**

Discharge: **1-1/2"** Solids: **1/4"**

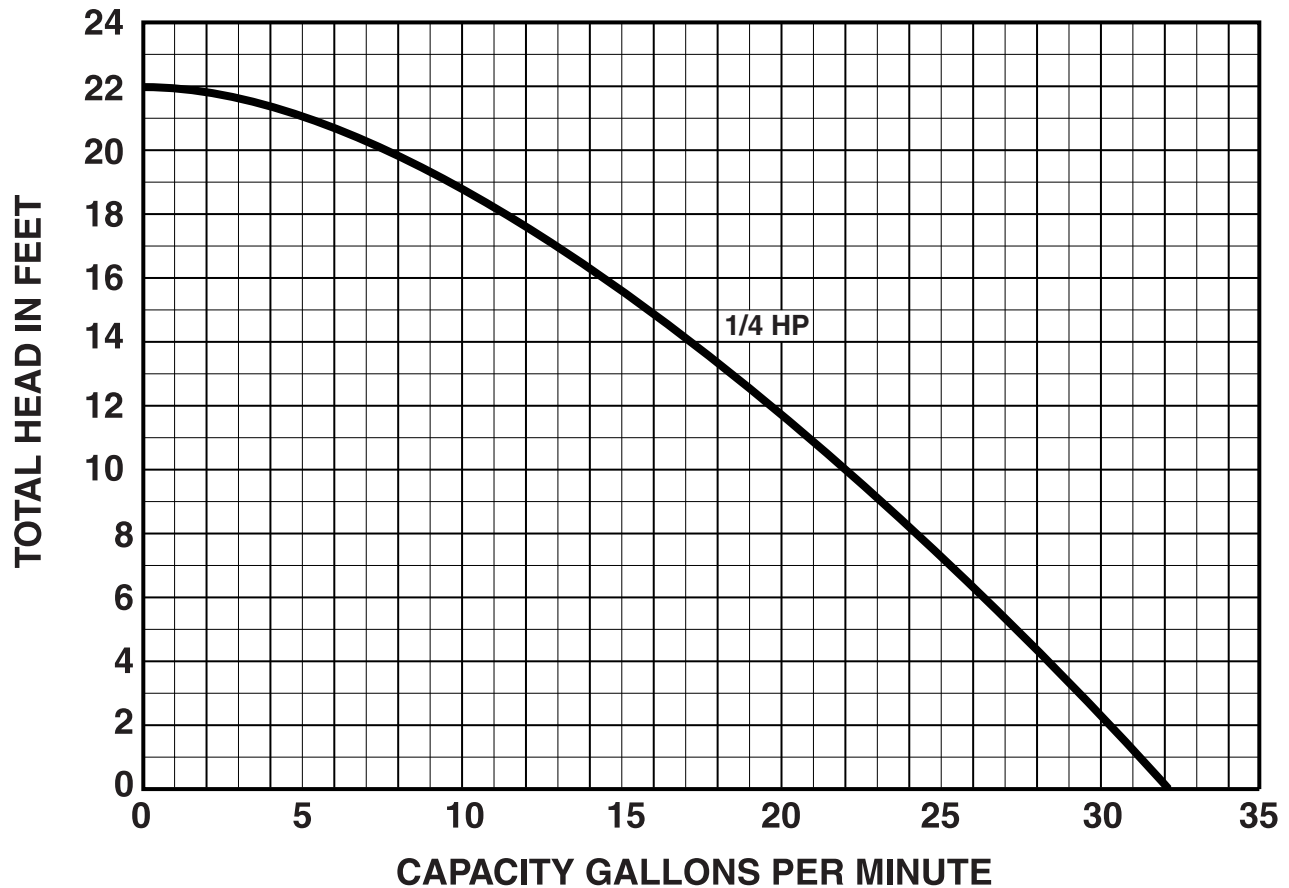
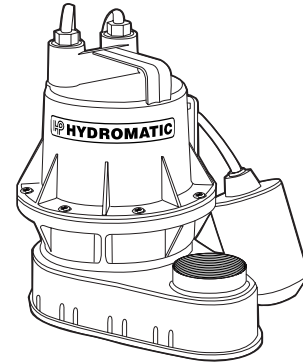

The curves reflect maximum performance characteristics without exceeding full load (Nameplate) horsepower. All pumps have a service factor of 1.2. Operation is recommended in the bounded area with operational point within the curve limit. Performance curves are based on actual tests with clear water at 70° F. and 1280 feet site elevation.

Conditions of Service:

GPM: _____ TDH: _____



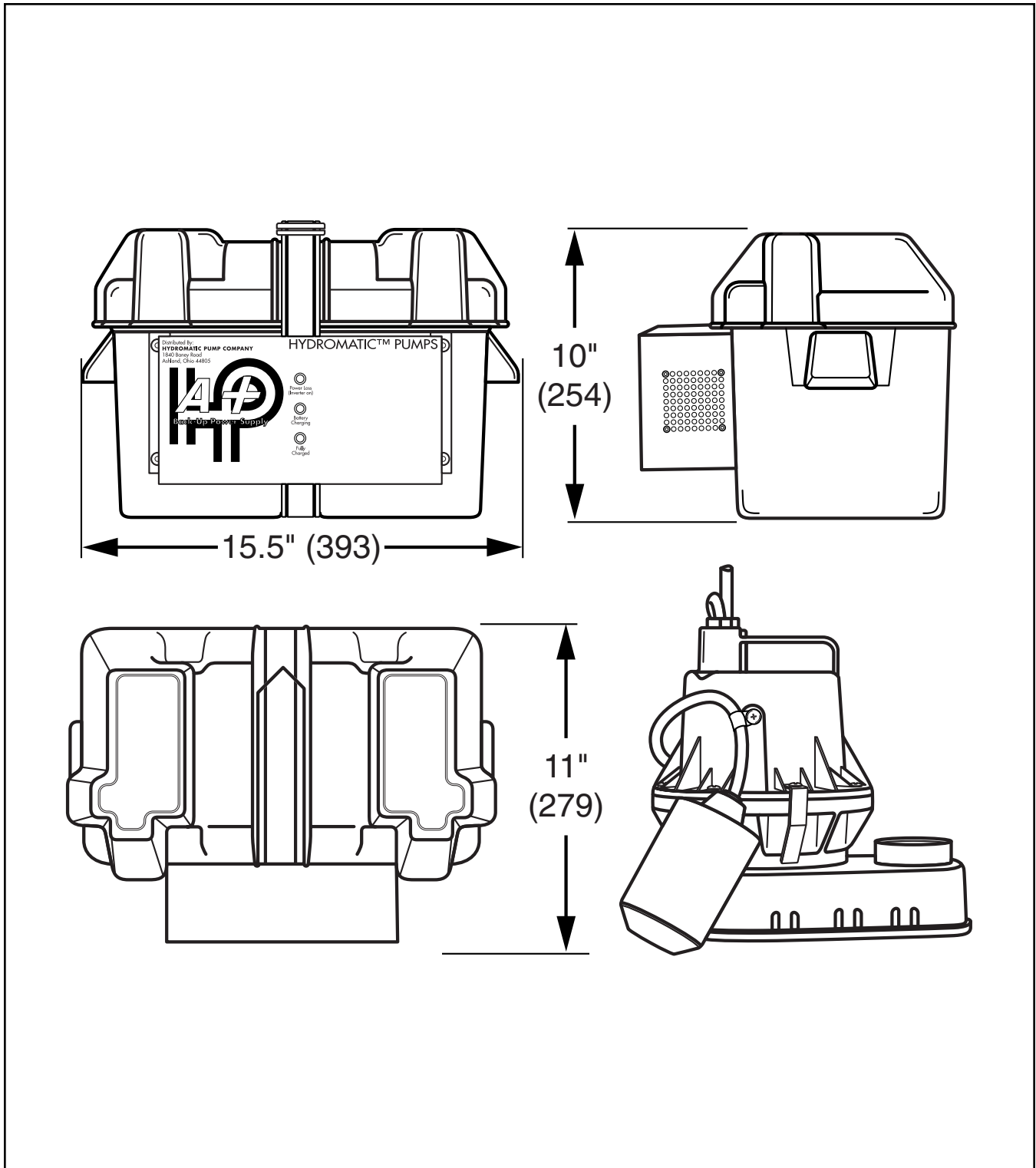

All dimensions in inches. Metric for international use. Component dimensions may vary $\pm 1/8$ inch. Dimensional data not for construction purpose unless certified. Dimensions and weights are approximate. On/Off level adjustable. We reserve the right to make revisions to our product (s) and the product (s) specifications without notice.

MODEL: BA-1/BV-A1, Sump/Effluent

R.P.M.	3450
MOTOR TYPE	P.S.C. OIL FILLED MOTOR
GENERAL INSULATION CLASS	A
MAXIMUM STATOR TEMPERATURE	105°

HP	VOLTAGE	PHASE	NEC CODE	SERVICE FACTOR	FULL LOAD AMPS
1/4	115	1	-	1	6.5

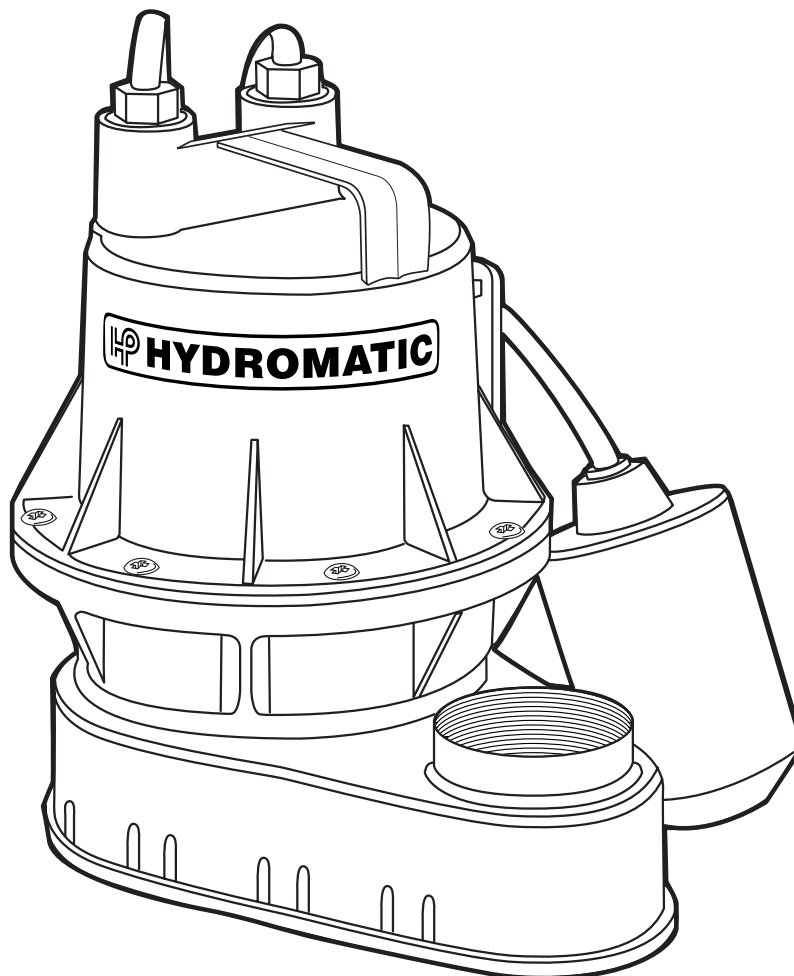

MODEL: BA-1/BV-A1, Sump/Effluent**Physical Data:**

DISCHARGE SIZE	1-1/2" NPT
SOLIDS SIZE	1/4"
IMPELLER TYPE	
CABLE LENGTH	10' STANDARD
PAINT	

Temperature:

MAXIMUM LIQUID	140°F
MAXIMUM STATOR	
OIL FLASH POINT	

Technical Data:

POWER CORD TYPE	SJTW	
MATERIALS OF CONSTRUCTION	MOTOR HOUSING	CAST IRON
	CASING	THERMOPLASTIC
	IMPELLER	THERMOPLASTIC
	MOTOR SHAFT	STEEL
	HARDWARE	STAINLESS STEEL
	"O" RINGS	
MECHANICAL SEALS Standard:		
UPPER BEARING	BALL BEARING	
LOWER BEARING	BALL BEARING	

SUBMERSIBLE SUMP/EFFLUENT MODELS: V-A1, W/D-A1, VS25/33, SW25/33 and SD25/33

1.01 GENERAL

Contractor shall furnish all labor, materials, equipment and incidentals required to provide _____ (Qty.) submersible centrifugal sewage grinder pump(s) as specified herein. The pump models covered in this specification are the V-A1, W/D-A1, VS25/33, SW25/33, and SD25/33. The pump furnished for this application shall be MODEL _____ as manufactured by Hydromatic Pumps.

2.01 DESIGN CONDITIONS

Each pump shall be rated _____ H.P., _____ volts, _____ phase, _____ hertz and operate at _____ RPM.

3.01 OPERATING CONDITIONS

The pump shall deliver _____ U.S. GPM/LPS at feet/meters TDK, and handle a _____ inch solid. The curve submitted for approval shall state, in addition to head and capacity performance, solid handling capability, amp rating, and design impeller diameter.

4.01 CONSTRUCTION

Each pump shall be of the sealed submersible type incorporating features normally found in pumps furnished for the heavy duty industrial or municipal markets.

These features include:

1. The pump volute, motor, and seal housing shall be high quality gray cast iron, ASTM A-48, Class 30.
2. The pump shall feature a multiple strainer inlet that prevents clogging from foreign objects and provides optimum operation and reduced maintenance.
3. All external mating parts shall be machined and Buna N, O-Ring sealed.
4. All fasteners exposed to the pumped liquid shall be 300 series stainless steel.
5. All power cords shall be water resistant UL or CSA approved with double insulation and sized as a function of Amp. draw.

5.01 MOTOR AND SHAFT

The stator, rotor and bearings shall be mounted in a sealed submersible type housing. Single phase motors shall be Shaded Pole, with automatic reset thermal overload protection. Full Load and, Locked Rotor Amps as well as Run winding resistance shall be tabulated for each pump.

6.01 BEARINGS, SHAFT AND MECHANICAL SEAL

An upper radial and lower thrust bearing shall be required. The upper bearing shall; be, Cast iron (V-A1 and W/D-A1) or Bronze (VS, SD and SW) while the lower bearing is heavy duty single row ball. They are both permanently, continuously lubricated and cooled by the dielectric oil, which fills the motor housing. The motor shaft shall be corrosion resistant steel and sealed from the pumped liquid with a carbon ceramic mechanical seal.

7.01 IMPELLER

The Impeller shall be a thermoplastic, eight vane, non-clog design with three pump out vanes on the back side. These vanes wash out grit and stringy material that will damage the shaft and mechanical seal.

8.01 AUTOMATIC CONTROL

All pumps should be capable of automatic operation.

9.01 PRESSURE SWITCH

The D-A1, SD25, and SD33 Single Phase pumps are furnished with a pressure diaphragm switch that is UL listed for water and sewage and GSA certified. The diaphragm switch cord shall be fitted with a piggy-back plug that allows the pump to be operated manually without removal from the sump.

10.01 FLOAT SWITCH

The W-A1, SW25, and SW33 Single Phase pumps are supplied with a tilt-sensitive wide-angle float switch which is sealed in a non-corrosive PVC enclosure. The switch is UL listed for water and sewage and QSA certified. The float switch shall also be fitted with a piggy-back plug that allows the pump to be operated manually without removal from the sump.

11.01 VERTICAL MECHANICAL SWITCH

The V-A1, VS25 and VS33 single phase pumps are furnished with a magnetic mechanical switch which is sealed in a non-corrosive PVC enclosure. The switch will be activated by a PVC float sliding up and down a non-corrosive rod. The mechanical switch cord shall also be fitted with a piggy-back plug that allows the pump to be operated manually without removal from the sump.

12.01 PAINTING

All cast iron parts shall be painted before assembly with a water reducible alkyd air dried enamel. The paint shall be applied in one coat with a minimum thickness of 3 to 4 mils.

13.01 TESTING

All pumps shall be individually tested to include the following:

1. The pump and power cord shall be visually inspected for imperfections, cuts or nicks.
2. The pump shall have a ground continuity check and the motor chamber shall be Hi-potted to test for moisture content and/or insulation defects.
3. The motor and volute housing shall be pressurized and a 10 second air leak decay test run.
4. A specific amount of oil is now added. The pump is run in a fully automated, sequenced, control console, which monitors voltage, current and watts visually and electronically. The tester listens for any noise or malfunction.