

WHR and WHR-DS

2" Solids Handling Sewage Pumps
Single and Double Seal



THE WHR SERIES PUMPS ARE DESIGNED FOR USE IN LIGHT COMMERCIAL AND RESIDENTIAL RAW SEWAGE APPLICATIONS. WHR pumps will pass a full 2-inch sphere. The recessed vortex impeller provides an unobstructed passage in the volute case which allows these pumps to handle stringy, trashy solids without plugging the impeller. The vortex impeller also greatly extends the pumps bearing life. Available in double seal configuration for extended motor life. For more information, call your Myers distributor or the Myers Ohio sales office at 419-289-6898.

ADVANTAGES BY DESIGN

DURABLE MOTOR

- Oil-filled for cooler operation and constant bearing lubrication.
- Single phase PSC motors have no starting switch to fail.
- Recessed impeller reduces radial bearing loads, increases bearing life.

NON-CLOG OPERATION

- Recessed vortex impeller passes 2" solids.
- Impeller operates completely out of volute passage.
- Passes stringy trash and other solids which conventional semi-open impellers can not.

AVAILABLE WITH AUTOMATIC PIGGY-BACK SWITCH FOR MAINTENANCE-FREE OPERATION

- Piggy-backed mechanical float switch allows pump to operate automatically or can be unplugged for manual operation.

PRODUCT CAPABILITIES

Capacities To	175 gpm	662 lpm
Heads To	33 ft.	10.1 m
Solids Handling	2 in.	50.8 mm
Liquids Handling	raw, domestic and light commercial sewage	
Intermittent Liquid Temp.	140°F	60°C
Winding Insulation Temp. (Class B)	266°F	130°C
Motor	1/2 HP, 115V, 1Ø, 60 Hz, PSC 1/2, 3/4, 1 HP, 230V 1Ø, 60 Hz, PSC 200/230/460/575V, 3Ø, 60 Hz	
Acceptable pH Range	6-9	
Specific Gravity	.9-1.1	
Discharge, NPT (Optional)	2 in. 3 in.	50.8 mm 76.2 mm
Minimum Sump Dia. Simplex	24 in.	609.6 mm
Duplex	30 in.	762.0 mm

Construction Materials

Motor Housing	cast iron	
Volute Case	cast iron	
Impeller	cast iron, vortex	
Power Cord	Single Seal 16/3, 20 ft., 1Ø 16/4, 20 ft., 3Ø SJOW/SJOWA	Double Seal 14/4, 20 ft. 1Ø 14/3, 20 ft., 1Ø L/D 16/4, 20 ft., 3Ø L/D
Mechanical Seal (Optional)	single, type 21. carbon/ceramic double tandem, carbon/ceramic	
Pump, Motor Shaft	416 SST	

WHERE INNOVATION MEETS TRADITION

Myers[®]

Pentair Water

DIMENSIONS

() Dimensions in mm

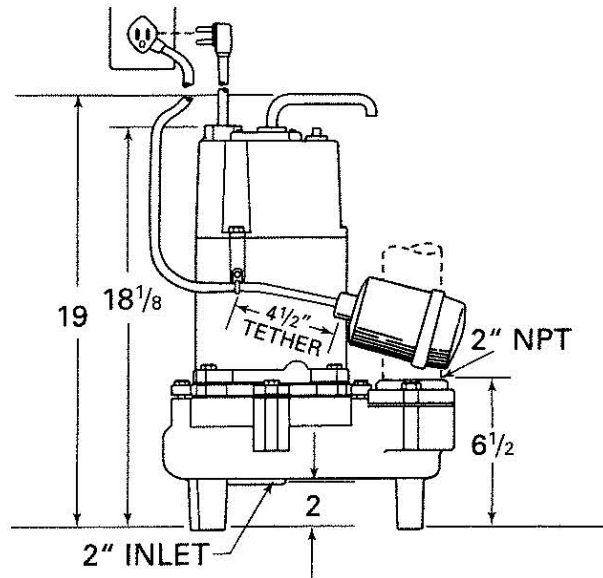
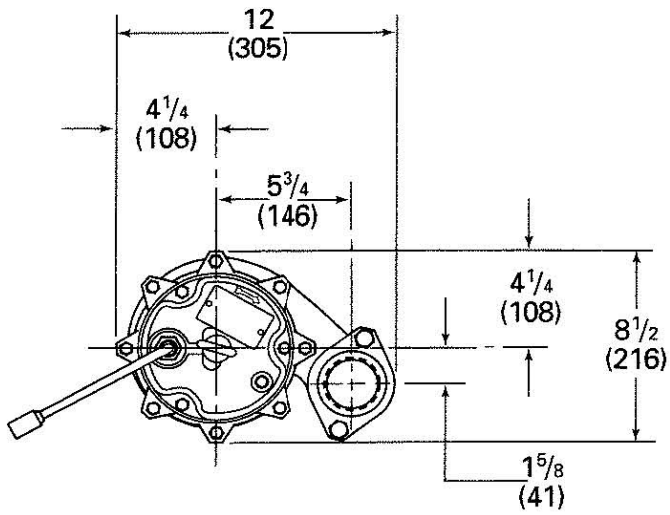

WHR-P

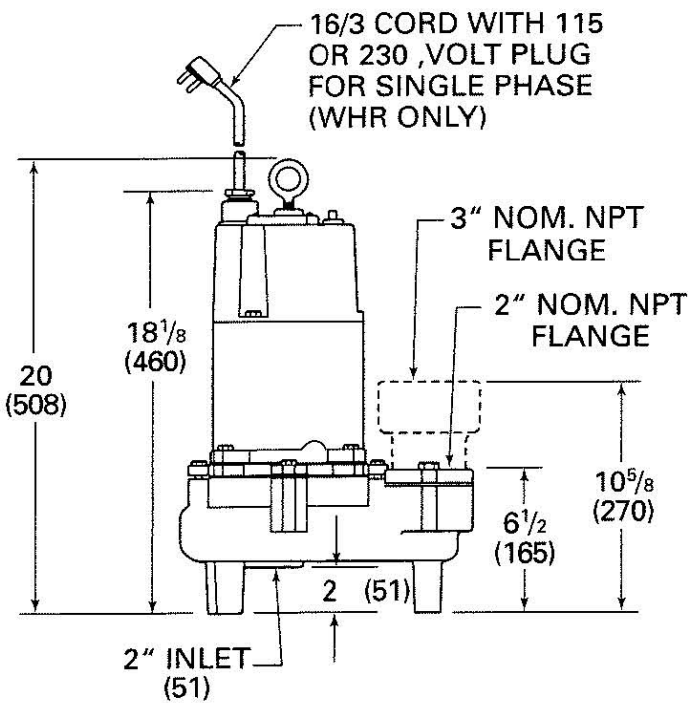

WHR

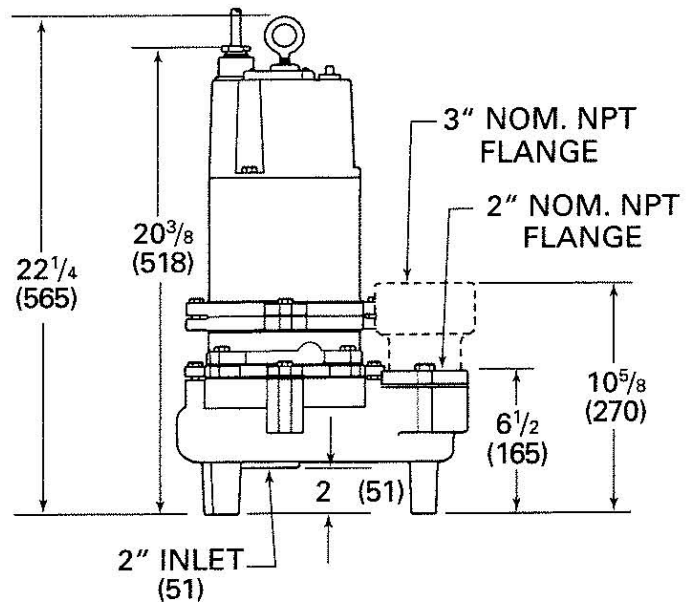

WHR-DS

PUMP PERFORMANCE

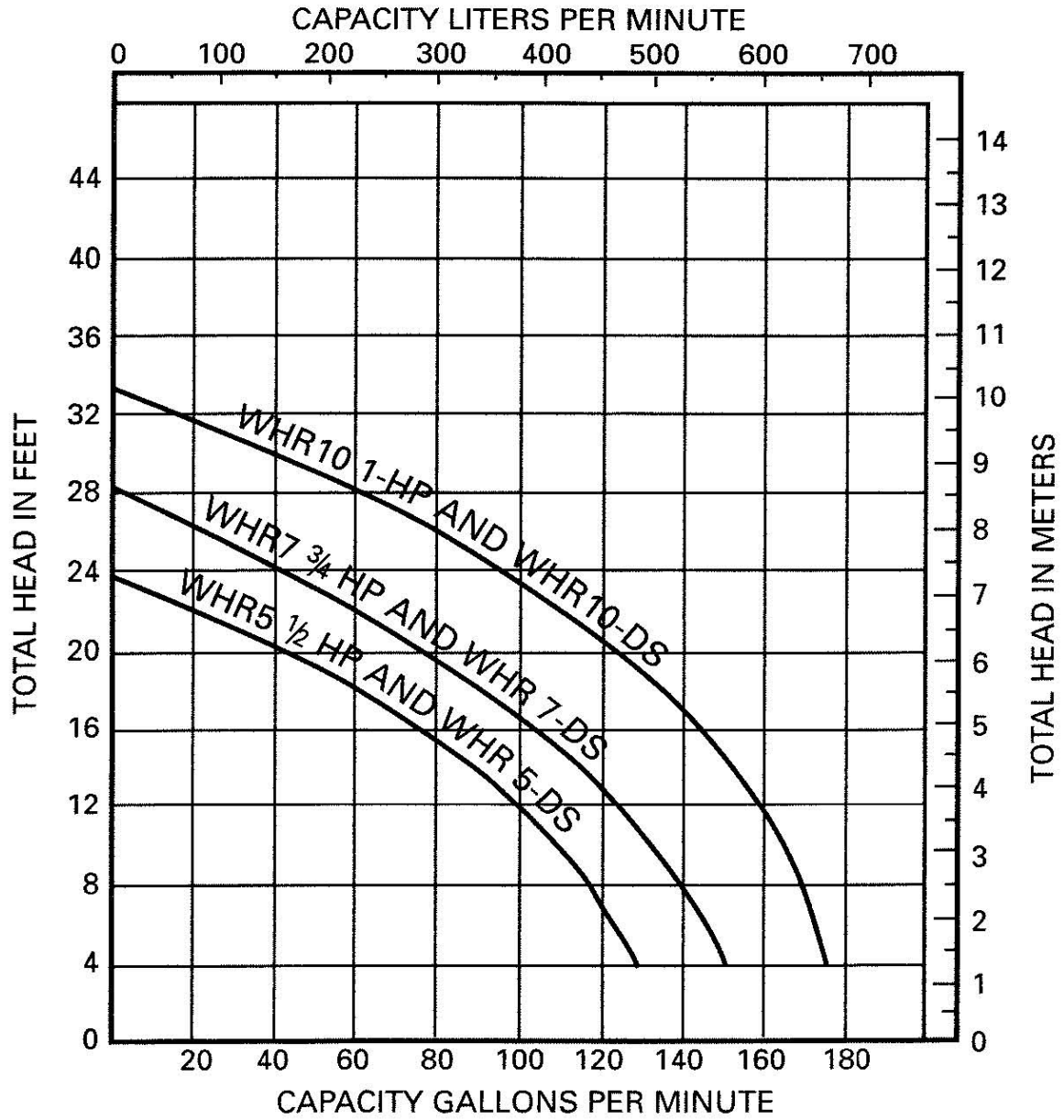

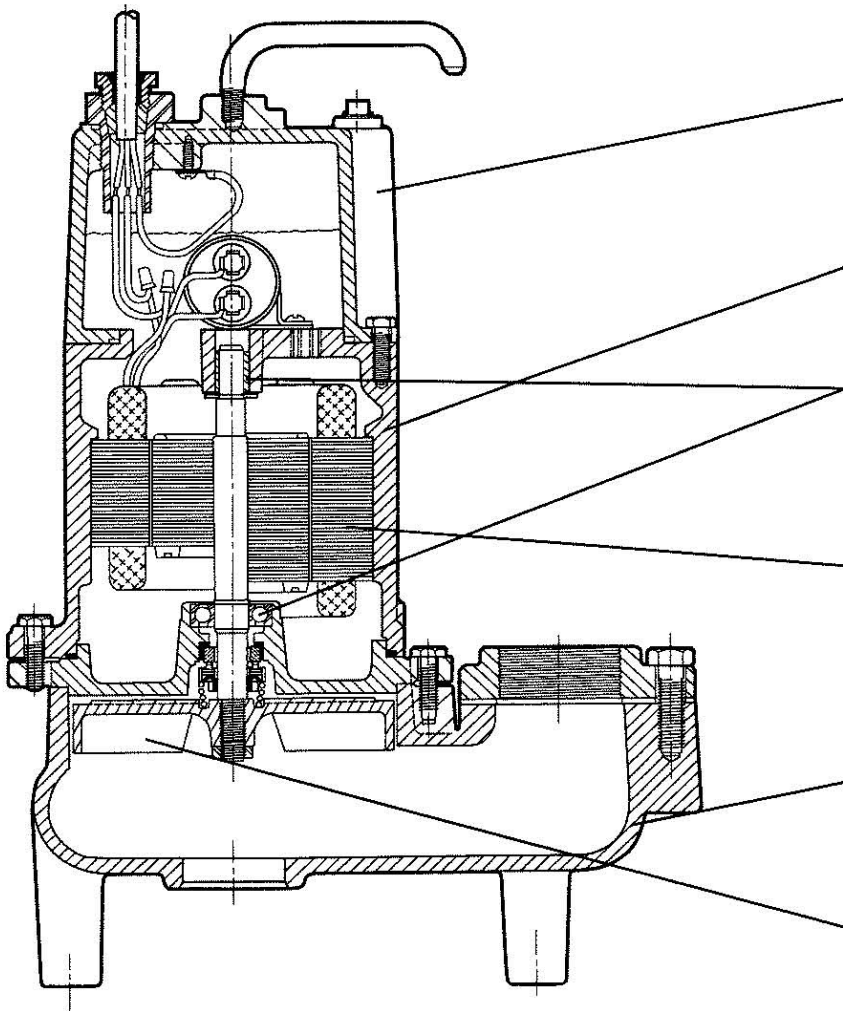

SEPARATE CAPACITOR HOUSING
Permits capacitor replacement (single phase only) without dismantling motor.

MOTOR HOUSING
Cast iron; pressed-in stator for best heat transfer and alignment.

BEARINGS
Support rotor. Take radial and thrust loads.

MOTOR
 $\frac{1}{2}$, $\frac{3}{4}$, or 1 HP. Single or three phase, 60 Hz, 1750 rpm. Oil-cooled and lubricated. Permanent split capacitor (1 \emptyset).

VOLUTE CASE
Cast iron with support legs. Passes 2" solids.

IMPELLER
Recessed completely out of volute passage.

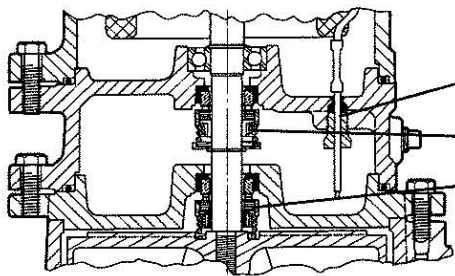

SEAL LEAK PROBE
Optional probes (single phase only) detect water leakage in seal housing. Activates warning light.

SHAFT SEAL(S)
Carbon and ceramic faces. Dual tandem seals extends motor life.

SPECIFICATIONS

OPERATING CONDITIONS: Each pump shall have a capacity of ___ GPM at a total head of ___ feet and motor size shall be ___ horsepower, ___ phase 60 Hz for operation at ___ volts and complete performance as shown on curve sheet.

PUMP: The sewage pump shall be WHR series as manufactured by F. E. Myers, Ashland, Ohio or equal. Pump shall be of the submersible type with recessed impeller to give complete unobstructed volute opening for passing of solids. Pump shall pass 2" diameter solids.

Discharge of pump shall be provided with bolt on 2" NPT flange or optional 3" NPT flange so that 2" or 3" pipe size may be used.

MOTOR: Pump motor shall be of the submersible type rated 1/2, 3/4, or 1 horsepower as required. Motor shall operate at 1750 RPM and shall be for 208 or 230 volts single phase or 200, 230, 460, or 575 volts three phase. Single phase motors shall be of the permanent split capacitor type with no relays or starting switches.

Stator winding shall be of the open type with Class A (105°C) insulation for operating in clean dielectric oil that lubricates bearings and seals and cools the winding. Stator shall be pressed into housing for the best alignment and heat transfer.

Common motor pump shaft shall be of 416 stainless steel and shall be heat shrunk into the die cast motor rotor. Rotor shaft shall be supported by a lower ball bearing to take thrust and radial loads and by an upper bronze sleeve bearing to take radial load only.

Single phase motor shall have an overload element embedded in the winding to protect the motor against over current and overheating conditions. Overload element shall automatically reset when motor cools.

Three phase motor shall be protected by 3 leg overload element in control box. Overload shall be of the quick trip ambient compensated type and shall have a manual reset button.

Motor to be a completely assembled unit with end plate for mounting in volute case. Complete motor and pump impeller to be removable as a unit from the volute casing.

CORROSION PROTECTION: All iron castings shall be pretreated with phosphate and chromic rinse and shall be painted with a high quality, lead free, alkyd enamel air dry paint. All fasteners to be 302 stainless steel.

SHAFT SEALS (Single Seal): Motor shall be protected by a rotating mechanical seal. Seal face shall be carbon and ceramic and lapped to a flatness of one light band.

SHAFT SEALS (Double Seal): Motor shall be protected by two mechanical seals mounted in tandem with a seal chamber between the seals. Seal chamber shall be oil filled to lubricate seal face and to transmit heat from shaft to outer shell. Seal face shall be carbon and ceramic and lapped to a flatness of one light band.

An optional electrode (1 phase only) shall be mounted in the seal chamber to detect any water entering the chamber through the lower seal. Water in the chamber shall cause a red light to turn on at the control box. This signal shall not stop the motor, but shall act as a warning only, indicating service is required.

IMPELLER: Shall be cast iron and of the recess type. Pump-out vane shall be used on back shroud. Impeller shall be dynamically balanced. Impeller to be threaded on shaft and held in position with locknut. Impeller and motor shall have top lift-out of case so that the assembly can be removed without disturbing any piping.

PUMP CASE: The volute case shall be of cast iron and shall be provided with bolt-on flange so the 2" pipe size may be used.

CORD SEAL: The cord shall be potted into a steel connector with polyurethane resin for leak proof seal. A cord nut and rubber grommet shall clamp the cord into the bushing. Cords shall withstand a pull of 100 pounds.