

WHR5H - WHR20H

2" Solids Handling
Sewage Pumps and Effluent Pumps
Single Seal

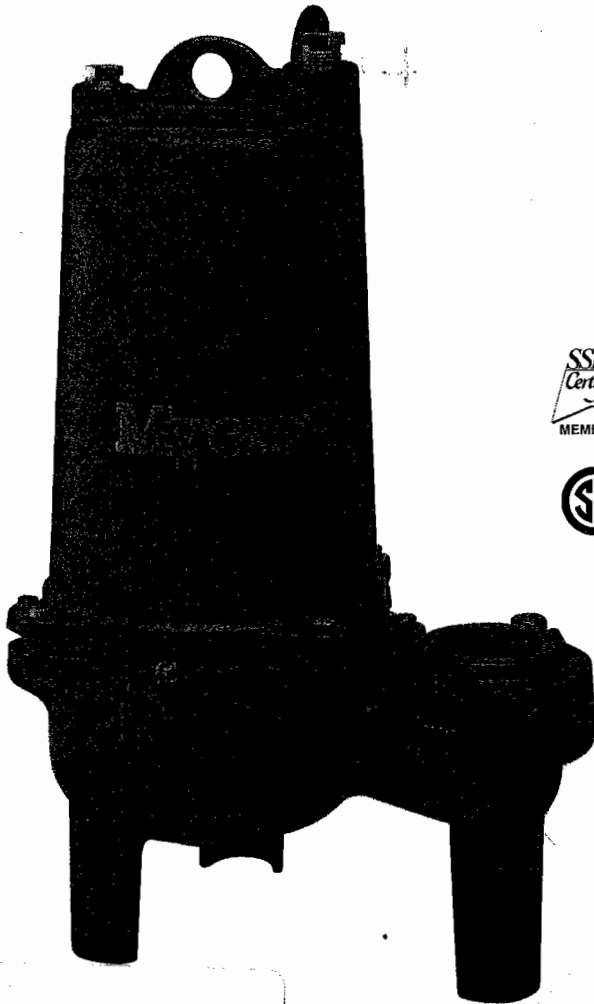

ADVANTAGES BY DESIGN

DURABLE MOTOR WILL DELIVER MANY YEARS OF RELIABLE SERVICE.

- Oil-filled motor for maximum heat dissipation and constant bearing lubrication.
- Recessed vortex impeller reduces radial bearing loads, increases bearing life.
- Single phase PSC motors have no starting switch.

NON-CLOG OPERATION

- Recessed vortex impeller passes 2" solids.
- Impeller operates completely out of volute passage
- Passes stringy trash and other solids which conventional semi-open impellers can't.

PRODUCT CAPABILITIES

Capacities To	215 GPM	814 LPM
Heads To	70 ft.	20.9 m
Solids Handling Capacity	2 in.	50.6 mm
Liquids Handling	raw and effluent sewage	
Intermittent Liquid Temp.	up to 140° F	up to 60° C
Winding Insulation Temp. (Class B)	266° F	130° C
Motor Electrical Data	1/2, 1, 1½, 2 HP, 3450 RPM 115, 208/230V, 1Ø, 60 Hz PSC 200/230/460/575V, 3Ø, 60 Hz	
Third Party Approvals	CSA	
Acceptable pH Range	6 - 9	
Specific Gravity	.9 - 1.1	
Discharge, NPT (optional)	2 in. 3 in.	50.8 mm 76.2 mm
Min. Sump Diameter		
Simplex	24 in.	61.0 cm
Duplex	30 in.	91.4 cm

Note: Consult factory for applications outside of these recommendations.

THE WHR5H-WHR20H SERIES PUMPS ARE DESIGNED FOR USE IN LIGHT COMMERCIAL AND RESIDENTIAL RAW SEWAGE AND EFFLUENT APPLICATIONS. They deliver higher heads than standard sewage pumps and will pass 2 inch solids. Recessed vortex impeller provides an unobstructed passage in the volute case, allowing the pump to handle stringy trash without plugging the impeller. For more information, call your Myers distributor, or the Myers Ohio sales office at 419-289-6898.

Construction Materials

Motor Housing	cast iron
Volute Case	cast iron
Impeller	ductile iron
Power Cord	single seal 1Ø, 20' SJOOW/SJOOW-A 3Ø, 20' SJOOW
Mechanical Seal	single, type 21, carbon and ceramic
Pump Shaft and Motor Shaft	416 SST

WHERE INNOVATION MEETS TRADITION

Myers®

Pentair Water

PUMP PERFORMANCE

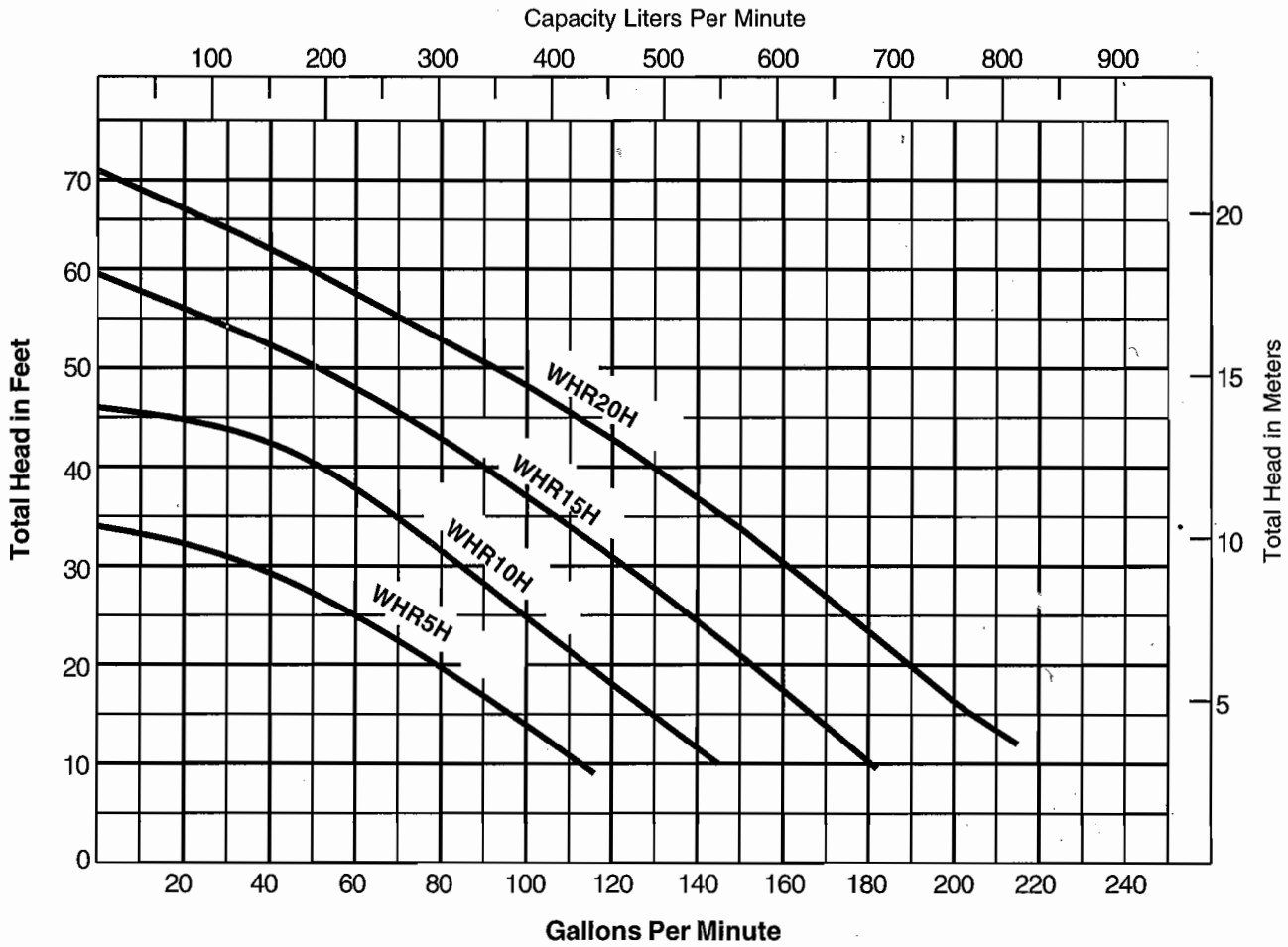

Motor Electrical Data										
Model	HP	Volts	Phase	Hertz	Start Amps	Max. Amps	Max. KW	Start KVA	Max. KVA	NEC Code Letter
WHR5H-11	1/2	115	1	60	30.4	13.8	1.9	3.5	1.6	H
WHR5H-01	1/2	208	1	60	16.2	7.6	1.7	3.4	1.6	H
WHR5H-21	1/2	230	1	60	16.2	6.9	1.7	3.7	1.6	H
WHR5H-03	1/2	200	3	60	20.2	5.2	1.4	7.3	1.9	R
WHR5H-23	1/2	230	3	60	20.2	4.7	1.4	8.0	1.9	S
WHR5H-43	1/2	460	3	60	10.1	2.3	1.4	8.0	1.9	S
WHR5H-53	1/2	575	3	60	8.1	1.9	1.4	8.0	1.9	S
WHR10H-01	1	208	1	60	28.0	14.8	3.0	5.8	2.8	B
WHR10H-21	1	230	1	60	23.0	12.8	3.0	5.3	2.8	B
WHR10H-03	1	200	3	60	30.0	7.7	2.5	10.8	3.0	J
WHR10H-23	1	230	3	60	30.0	7.0	2.5	10.8	3.0	K
WHR10H-43	1	460	3	60	15.0	3.5	2.5	11.9	3.0	K
WHR10H-53	1	575	3	60	12.0	2.8	2.5	11.9	3.0	K
WHR15H-01	1½	208	1	60	39.9	15.3	3.3	8.3	3.2	D
WHR15H-21	1½	230	1	60	33.4	13.1	3.3	7.7	3.0	C
WHR15H-03	1½	200	3	60	30.0	8.5	2.8	10.8	3.4	F
WHR15H-23	1½	230	3	60	30.0	7.7	2.8	11.9	3.1	G
WHR15H-43	1½	460	3	60	15.0	3.9	2.8	11.9	3.1	G
WHR15H-53	1½	575	3	60	12.0	3.1	2.8	11.9	3.1	G
WHR20H-21	2	230	1	60	63.0	18.0	3.8	14.5	3.7	E
WHR20H-03	2	200	3	60	53.0	10.4	3.3	19.1	3.6	G
WHR20H-23	2	230	3	60	46.0	9.0	3.3	18.3	3.6	G
WHR20H-43	2	460	3	60	23.0	4.5	3.3	18.3	3.6	G
WHR20H-53	2	575	3	60	18.4	3.6	3.3	18.3	3.6	G

POWER CORD

Jacket sealed with compression fittings. Individual wires potted with epoxy to prevent wicking in case of cord damage.

MOTOR HOUSING

Cast iron for efficient heat transfer and corrosion resistance.

BEARINGS

Upper and lower ball support rotor. Take radial and thrust loads.

MOTOR

1/2, 1 1-2 and 2 HP single or three phase, 60 Hz, 3450 RPM. Single phase PSC motors have built-in on winding overload protection, oil-cooled and lubricated.

CAST IRON VOLUTE

Corrosion resistant. Passes 2" spherical solids. 2" NPT discharge. Optional 3" flange.

IMPELLER

Recessed vortex impeller operates completely out of volute passage.

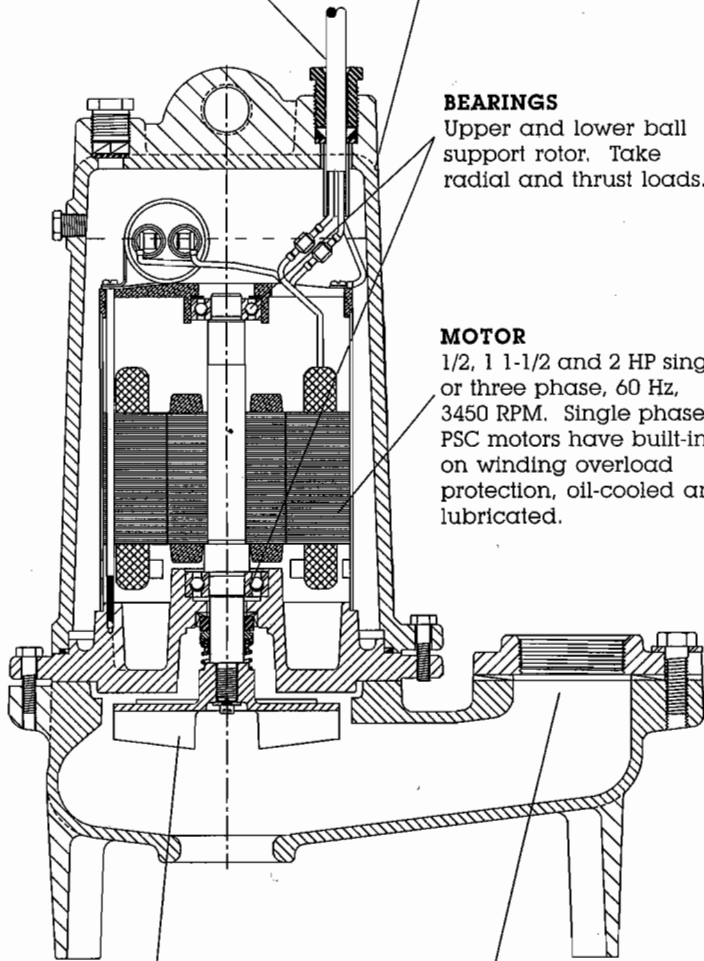

DIMENSIONS

(Dimensions in MM)

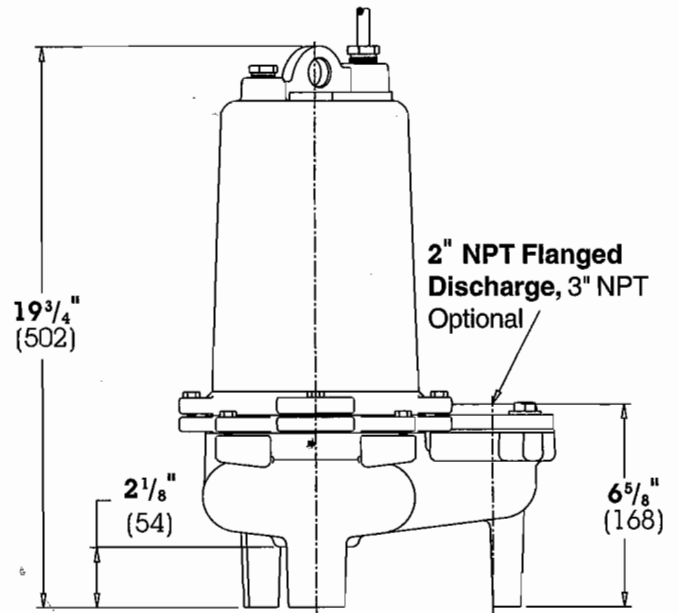
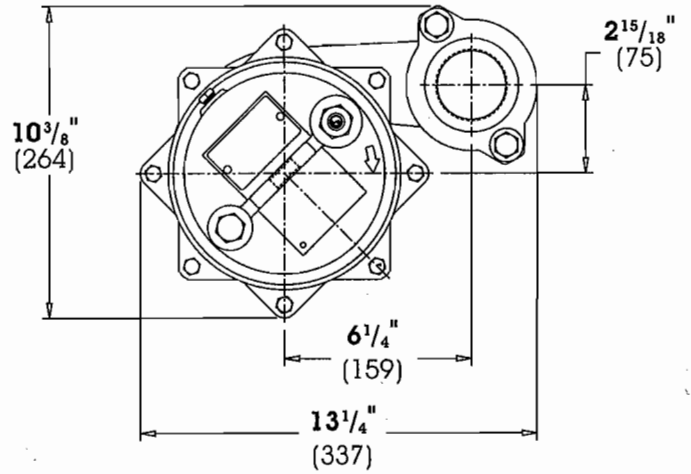

WHR5H - WHR20H

SPECIFICATIONS

SEWAGE PUMPS - Pump(s) shall be F. E. Myers WHR5H - WHR20H series sewage pumps selected in accordance with the following design criteria:

Number of Pumps:	_____
Primary Design Flow:	_____
Primary Design Head:	_____
Minimum Shut-off Head:	_____
Motor Horsepower:	_____
Motor Speed:	3450 RPM
Electrical:	_____

PUMP - The pump shall be designed to handle raw sewage and be capable of passing 2 inch spherical solids. The pump shall be capable of handling liquids with temperatures to 140°F intermittent and shall be capable of running dry without damage to the seals or bearings.

MOTOR - The pump motor shall be of the submersible type rated 1/2, 1, 1-1/2 or 2 hp as required. Motor shall operate at 3450 RPM and shall be for 115, 208 or 230 volts single phase, or 200, 230, 460, or 575 volts, 3 phase, 60 cycles. Single phase motors shall be of the permanent split capacitor type with no relays or starting switches. Three phase motors shall be squirrel cage induction type. Stator winding shall be of the open type with Class B insulation rated for 130°C maximum operating temperature. The winding housing will be filled with clean dielectric oil to lubricate bearings, seals, and transfer heat from the windings to the outer shell. The motor assembly shall be of the standard frame design and shall be secured in place by four threaded fasteners allowing for easy field servicability.

The motor shall be capable of operating over the full range of the performance curve without overloading the motor and causing any objectionable noise or vibration. The common motor pump shaft shall be of 416 stainless steel and shall be heat shrunk into the die cast motor rotor. The motor shall have two bearings to support the rotor; an upper ball bearing to accommodate radial loads and a lower ball bearing to take thrust and radial loads. Ball bearings shall be designed for a B-10 life of 50,000 hours.

A heat sensor thermostat and overload shall be attached to the top end of the motor windings and shall be wired in series with the windings to stop the motor if the motor winding temperature reaches 266°F. The overload thermostat shall reset automatically when the motor cools to a safe operating temperature. Three phase motors shall be protected by 3 leg overload relay in control box. Overload shall be of the quick trip ambient compensated type and shall have manual reset button.

POWER CORD - The motor power cord shall be SJOW/A for single phase and SOOW for three phase. The cable jacket shall be sealed at the motor entrance by means of a rubber compression washer and compression nut. A heat shrink tube filled with epoxy shall seal the outer cable jacket and the individual leads to prevent water from entering the motor housing.

SHAFT SEAL - The motor shall be protected by a rotating mechanical shaft seal. The seal shall have carbon and ceramic seal faces lapped to a tolerance of one light band. Metal parts and springs for seals shall be 300 series stainless steel.

PUMP IMPELLER - The pump impeller shall be of the recessed vortex type. The impeller shall be constructed of ductile iron. The impeller shall be threaded onto the 416 stainless steel pump/motor shaft.

PUMP AND MOTOR CASTINGS - All castings shall be of high tensile strength Class 30 gray cast iron. Castings shall be treated with phosphate rinse and painted with a high quality air dry alkyd enamel.

FASTENERS - All exposed fasteners shall be of 300 series stainless steel.