



submersible sump pumps



Automatic submersible sump pumps provide reliable protection and performance against flooded basements. The submersible design allows for quiet operation with a wide range of models available to accommodate a variety of applications. Switch choices include tethered styles for a wide range of on/off settings

or vertical style for narrow diameter sumps. Materials of construction include high-impact corrosion-resistant engineered resin. Other options include discharge size (1-1/2" FNPT).

APPLICATIONS

- Basement Sumps
- Dewatering

D125/D133/D150 SERIES

SPECIFICATIONS

Motor – Oil-cooled submersible, 115 Volts, single phase, 60 Hz
Base – High-impact corrosion-resistant engineered resin
Switch – Tethered or vertical style
Power Cord – 8' Type SJTW-A/SJTW
Discharge – 1-1/2" FNPT
Impeller – Corrosion-resistant thermoplastic, semi-open type
Maximum Liquid Temperature Limits – 77°F (25°C)

FEATURES

Switch – Tethered float style installs into sump diameter of 14" or larger. Vertical style installs into sump diameters of 10" or larger.
Intake – Screened intake prevents debris from entering the pump.
Oil-cooled Motor – Transfers heat to sump water efficiently while lubricating internal motor components.
Performance – Models range up to 54 gallons per minute at 5' of lift.
Easy Serviceability – Pump intake, impeller, base, switch, and power cord are serviceable.
Base Construction – High-impact corrosion-resistant engineered resin pump base is durable for residential application.

ORDERING INFORMATION

Catalog Number	HP	Max. Load Amps	Volts	Phase/Cycle	Cord Length	Mechanical Switch Type	Switch Setting	
							On	Off
D12518T	1/4	8.5	115	1/60	8'	Tethered	13"	6"
D12518V	1/4	8.5	115	1/60	8'	Vertical	8.5"	4"
D125115T	1/4	8.5	115	1/60	15"	Tethered	13"	6"
D13318T	1/3	9.0	115	1/60	8'	Tethered	13"	6"
D13318V	1/3	9.0	115	1/60	8'	Vertical	8.5"	4"
D133115T	1/3	9.0	115	1/60	15"	Tethered	13"	6"
D15018T	1/2	13.0	115	1/60	8'	Tethered	13"	6"
D15018V	1/2	13.0	115	1/60	8'	Vertical	8.5"	4"
D150115T	1/2	13.0	115	1/60	15'	Tethered	13"	6"

In order to provide the best products possible, specifications are subject to change.

PUMP PERFORMANCE

1/4 HP				
Vertical Lift Feet/Meters	5/1.5	10/3	15/4.6	Shut-Off 18/5.5
Gallons/Liters per Minute	38/144	30/114	14/53	No Flow
1/3 HP				
Vertical Lift Feet/Meters	5/1.5	10/3	15/4.6	Shut-Off 20/6.1
Gallons/Liters per Minute	46/174	36/136	24/91	No Flow
1/2 HP				
Vertical Lift Feet/Meters	5/1.5	10/3	15/4.6	20/6.1 Shut-Off 24/7.3
Gallons/Liters per Minute	54/204	45/170	33/125	20/76 No Flow

submersible sump pumps

VERTICAL FLOAT OUTLINE DIMENSIONS

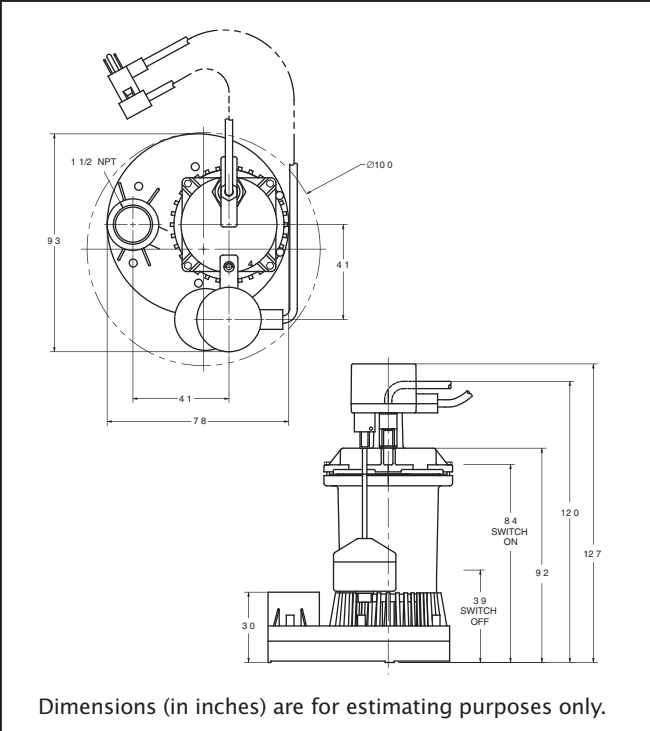

VERTICAL FLOAT SECTIONAL VIEW

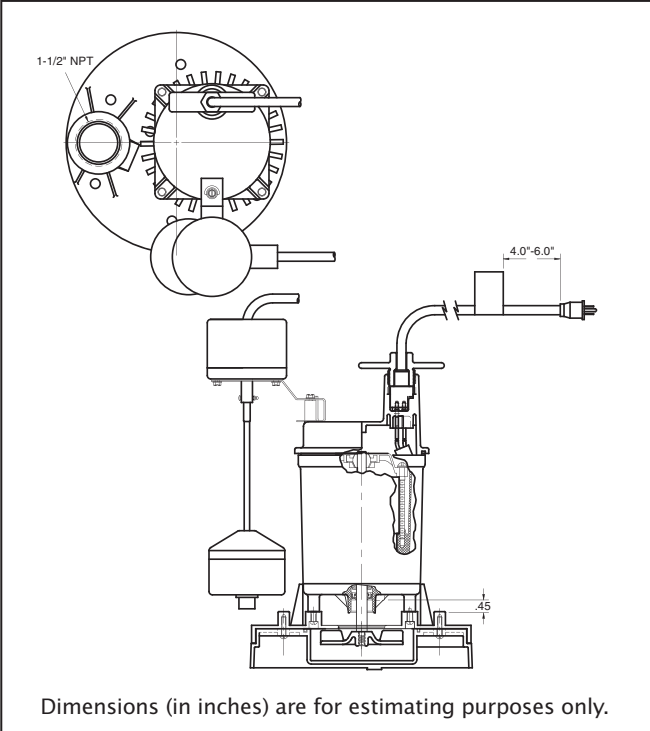

TETHERED FLOAT OUTLINE DIMENSIONS

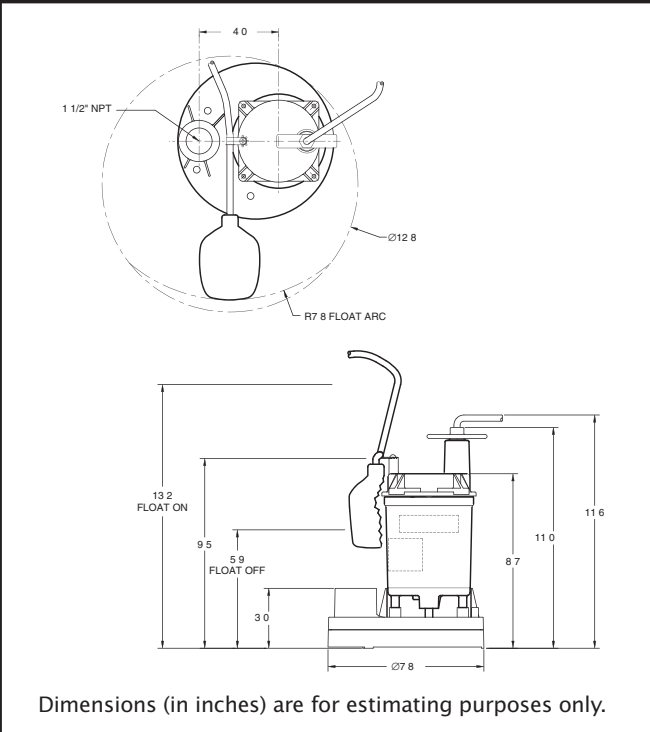

TETHERED FLOAT SECTIONAL VIEW

