

<b>DISCHARGE</b> .....	1½" NPT, Female, Vertical
<b>LIQUID TEMPERATURE</b> .....	104°F (40°C) Continuous
<b>MOTOR HOUSING</b> .....	Cast Iron
<b>PUMP STRAINER</b> .....	Thermoplastic
<b>IMPELLER:</b> <i>Design</i> .....	10 Vane vortex, with pump out vanes on back side. Balanced, ISO G6.3
<i>Material</i> .....	Cast Iron
<b>SHAFT</b> .....	Stainless Steel
<b>O-RINGS</b> .....	Buna-N
<b>HARDWARE</b> .....	300 Series Stainless Steel
<b>PAINT</b> .....	Air Dry Enamel
<b>SEAL:</b> <i>Design</i> .....	Single Mechanical, Type 21
<i>Material</i> .....	Carbon/Ceramic/Buna-N
<b>CORD ENTRY</b> .....	20 ft. (6m) Cord with plug and pressure Grommet for sealing and strain relief
<b>UPPER BEARING</b> .....	Single Row, Ball, Oil Lubricated
<b>LOWER BEARING</b> .....	Single Row, Ball, Oil Lubricated
<b>MOTOR:</b> <i>Design</i> .....	Oil Filled
<i>Insulation</i> .....	Class B
<b>SINGLE PHASE</b> .....	Permanent Split Capacitor (PSC). Includes thermal overload protection in motor
<b>LEVEL CONTROL</b>	
SP50X.....	None
SP50AX.....	Wide angle, Mechanical, 20 ft. (6m) cord
SP50VFX .....	Vertical float, PVC, snap action, 20 ft (6m) cord
<b>MINIMUM SUMP DIA:</b>	
SP50AX.....	18" (457mm)
SP50X & SP50VXF....	12" (305mm)
<b>NOTE</b> .....	GFCI Compatible to Comply with NEC 210.8 (A)

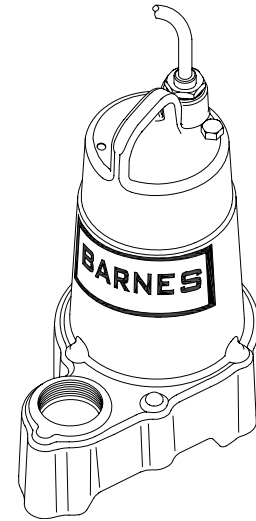

Series: SP50  
1/2HP, 3450RPM, 60Hz



CSA 108  
UL 778  
LR16567

**DESCRIPTION:**  
GENERAL PURPOSE PUMP FOR RESIDENTIAL AND LIGHT INDUSTRIAL SUMP APPLICATIONS

TOTAL HEAD  
METERS FEET



U.S. GALLONS PER MINUTE  
LITERS PER SECOND

Testing is performed with water specific gravity of 1.0 @ 68°F (20°C), other fluids may vary performance

# Series SP50

1/2" Spherical Solids Handling

Manual & Automatic, Submersible Sump /Effluent

# BARNES®

Professional Plumbing

www.cranepumps.com

## Sump Pumps

Model: SP50

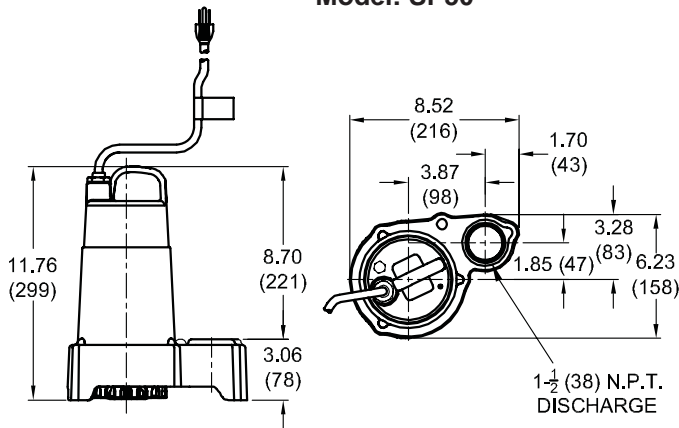

Model: SP50VF

inches  
(mm)

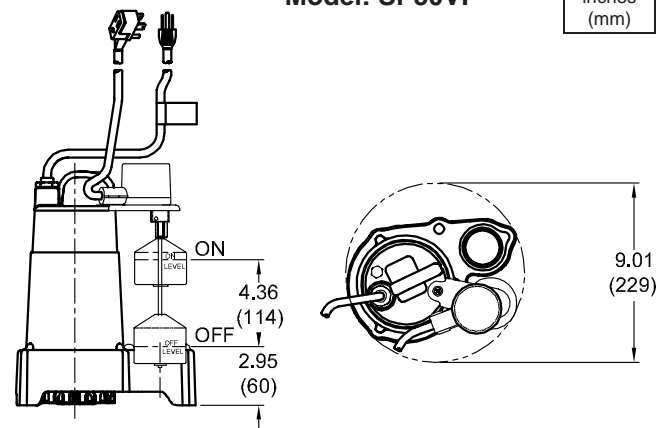

Model: SP50A

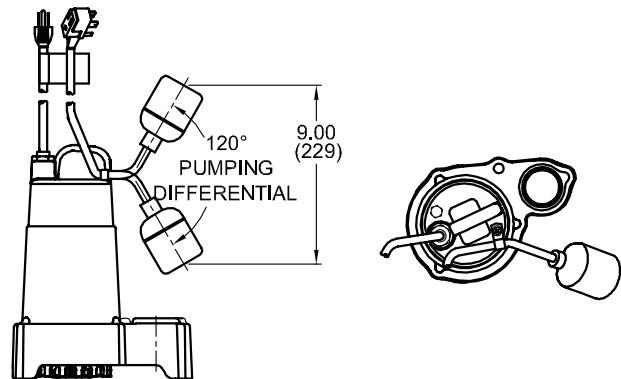

MODEL NO	PART NO	HP	VOLT/PH	Hz	RPM (Nom)	NEMA START CODE	FULL LOAD AMPS	CORD LENGTH	CORD SIZE	CORD TYPE
SP50X	112875	1/2	120/1	60	3450	A	6.8	20 ft. (6m)	18/3	SJTOW
SP50AX	112877	1/2	120/1	60	3450	A	6.8	20 ft. (6m)	18/3	SJTOW
SP50VFX	112879	1/2	120/1	60	3450	A	6.8	20 ft. (6m)	18/3	SJTOW

### IMPORTANT !

- 1.) PUMP MAY BE OPERATED "DRY" FOR EXTENDED PERIODS WITHOUT DAMAGE TO MOTOR AND/OR SEALS.
- 2.) THIS PUMP IS APPROPRIATE FOR THOSE APPLICATIONS SPECIFIED AS CLASS I DIVISION II HAZARDOUS LOCATIONS.
- 3.) THIS PUMP IS NOT APPROPRIATE FOR THOSE APPLICATIONS SPECIFIED AS CLASS I DIVISION I HAZARDOUS LOCATIONS.
- 4.) INSTALLATIONS SUCH AS DECORATIVE FOUNTAINS OR WATER FEATURES PROVIDED FOR VISUAL ENJOYMENT MUST BE INSTALLED IN ACCORDANCE WITH THE NATIONAL ELECTRIC CODE ANSI/NFPA 70 AND/OR THE AUTHORITY HAVING JURISDICTION. THIS PUMP IS NOT INTENDED FOR USE IN SWIMMING POOLS, RECREATIONAL WATER PARKS, OR INSTALLATIONS IN WHICH HUMAN CONTACT WITH PUMPED MEDIA IS A COMMON OCCURRENCE.

SECTION A  
PAGE 6  
DATE 7/10

## CRANE®

A Crane Co. Company

## PUMPS & SYSTEMS

USA: (937) 778-8947 • Canada: (905) 457-6223 • International: (937) 615-3598