

BARNES®

INSTALLATION MANUAL Submersible Fountain Pump

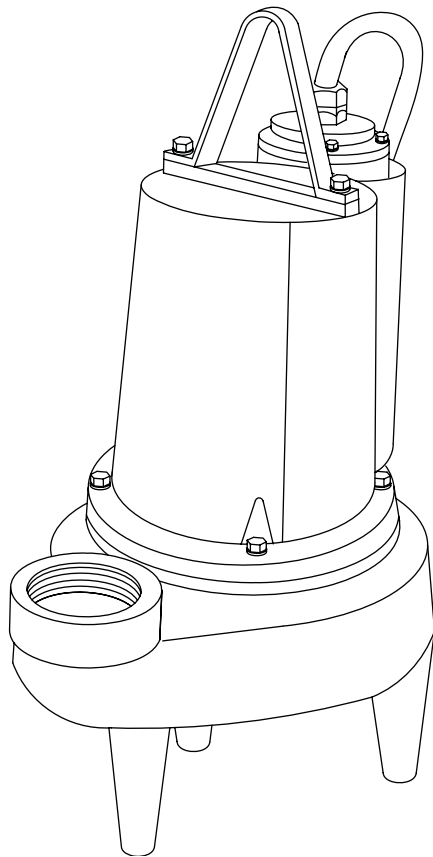

Series: 3SF
3HP, 1750RPM, 60Hz

IMPORTANT!

*Read all instructions in this manual before operating pump.
As a result of Crane Pumps & Systems, Inc., constant product improvement program,
product changes may occur. As such Crane Pumps & Systems reserves the right to
change product without prior written notification.*

CRANE

A Crane Co. Company

PUMPS & SYSTEMS

420 Third Street
Piqua, Ohio 45356
Phone: (937) 778-8947
Fax: (937) 773-7157
www.cranepumps.com

83 West Drive, Bramton
Ontario, Canada L6T 2J6
Phone: (905) 457-6223
Fax: (905) 457-2650



Form No. 110001-Rev. G

TABLE OF CONTENTS

SAFETY FIRST	3
A. PUMP SPECIFICATIONS	4
B. GENERAL INFORMATION	5
C. INSTALLATION	5 - 6
ELECTRICAL DATA	6
D. START-UP OPERATION	6
E. PREVENTATIVE MAINTENANCE	6
F. SERVICE and REPAIR	7 - 9
G. REPLACEMENT PARTS.....	10
RETURNED GOODS POLICY.....	10
TRUBLE SHOOTING	11
CROSS-SECTION (Figure. 8).....	12
EXPLODED VIEW (Figure. 9).....	13
PARTS LIST	14 - 15
WARRANTY	
START-UP REPORT	
WARRANTY REGISTRATION	
SPECIAL TOOLS AND EQUIPMENT	
INSULATION TESTER (MEGGER)	
DIELECTRIC TESTER	
SEAL TOOL KIT (see parts list)	
PRESSURE GAUGE KIT (see parts list)	

SAFETY FIRST!

Please Read This Before Installing Or Operating Pump. This information is provided for **SAFETY** and to **PREVENT EQUIPMENT PROBLEMS**. To help recognize this information, observe the following symbols:



IMPORTANT! Warns about hazards that can result in personal injury or indicates factors concerned with assembly, installation, operation, or maintenance which could result in damage to the machine or equipment if ignored.

CAUTION! Warns about hazards that **can or will cause minor** personal injury or property damage if ignored. Used with symbols below.

WARNING! Warns about hazards that can or will cause serious personal injury, death, or major property damage if ignored. Used with symbols below.



Hazardous fluids can cause fire or explosions, burns or death could result.



Extremely hot - Severe burns can occur on contact.



Biohazard can cause serious personal injury.



Hazardous fluids can cause hazardous pressure, eruptions or explosions could cause personal injury or property damage.



Rotating machinery Amputation or severe laceration can result.



Hazardous voltage can shock, burn or cause death.

Only qualified personnel should install, operate and repair pump. Any wiring of pumps should be performed by a qualified electrician.

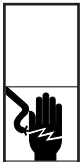

WARNING! To reduce risk of electrical shock, pumps and control panels must be properly grounded in accordance with the National Electric Code (NEC) or the Canadian Electrical Code (CEC) and all applicable state, province, local codes and ordinances. Improper grounding voids warranty.



WARNING! To reduce risk of electrical shock, always disconnect the pump from the power source before handling or servicing. Lock out power and tag.



WARNING! Operation against a closed discharge valve will cause premature bearing and seal failure on any pump, and on end suction and self priming pump the heat build may cause the generation of steam with resulting dangerous pressures. It is recommended that a high case temperature switch or pressure relief valve be installed on the pump body.



WARNING! This Pump is **NOT** intended for use in swimming pools.

Pumps when used as a decorative fountain pump **MUST** be used in a circuit protected by a Ground Fault Interrupter.



CAUTION! Pumps build up heat and pressure during operation-allow time for pumps to cool before handling or servicing.



WARNING! Do not pump hazardous materials (flammable, caustic, etc.) unless the pump is specifically designed and designated to handle them.



WARNING! Do not wear loose clothing that may become entangled in moving parts.



WARNING! Keep clear of suction and discharge openings. **DO NOT** insert fingers in pump with power connected.



Always wear eye protection when working on pumps.

Make sure lifting handles are securely fastened each time before lifting. **DO NOT** operate pump without safety devices in place. Always replace safety devices that have been removed during service or repair. Secure the pump in its operating position so it can not tip over, fall or slide.



DO NOT exceed manufacturers recommendation for maximum performance, as this could cause the motor to overheat.

DO NOT remove cord and strain relief. **DO NOT** connect conduit to pump.



WARNING! Cable should be protected at all times to avoid punctures, cut, bruises and abrasions. Inspect frequently. Never handle connected power cords with wet hands.



WARNING! To reduce risk of electrical shock, all wiring and junction connections should be made per the NEC or CEC and applicable state or province and local codes. Requirements may vary depending on usage and location.



WARNING! Products returned must be cleaned, sanitized, or decontaminated as necessary prior to shipment, to insure that employees will not be exposed to health hazards in handling said material. All Applicable Laws And Regulations Shall Apply.



Bronze/brass and bronze/brass fitted pumps may contain lead levels higher than considered safe for potable water systems. Lead is known to cause cancer and birth defects or other reproductive harm. Various government agencies have determined that leaded copper alloys should not be used in potable water applications. For non-leaded copper alloy materials of construction, please contact factory.

Crane Pumps & Systems, Inc. is not responsible for losses, injury, or death resulting from a failure to observe these safety precautions, misuse or abuse of pumps or equipment.

SECTION: A - PUMP SPECIFICATIONS:

DISCHARGE 3" NPT, Vertical
LIQUID TEMP 104°F (40°C) Continuous
MOTOR HOUSING Cast Iron ASTM A-48, Class 30
VOLUTE Cast Iron ASTM A-48, Class 30
SEAL PLATE Cast Iron ASTM A-48, Class 30
IMPELLER:
Design.....2 Vane, Open with Pump out vanes on Back side. Dynamically balanced, ISO G6.3
Material Cast Iron ASTM A-48, Class 30
SHAFT..... 416 Stainless Steel
SQUARE RINGS..... Buna-N
HARDWARE 300 Series Stainless Steel
PAINT Air dry enamel, top coat
SEAL *Design*..... Inboard, Single Mechanical with oil filled reservoir, secondary exclusion seal
Material Rotating Faces - Carbon
 Stationary Faces - Ceramic
 Elastomer - Buna-N
 Hardware - 300 series stainless steel
CORD ENTRY 25 Ft. (7.6m) Cord, Pressure Grommet for sealing and strain relief
SPEED 1750 RPM, 60Hz (nominal)

UPPER BEARING:
Design..... Single Row, Ball, Oil Lubricated
Load..... Radial
LOWER BEARING:
Design..... Single Row, Ball, Oil Lubricated
Load..... Radial & Thrust
MOTOR: *Design*..... NEMA L, Single phase, Torque Curve, Oil Filled, Squirrel Cage Induction
Insulation..... Class B
SINGLE PHASE..... Permanent Split Capacitor (PSC)
 Includes overload protection in motor
OPTIONAL EQUIPMENT:
 Seal Material, Impeller Trims, Additional Cord,

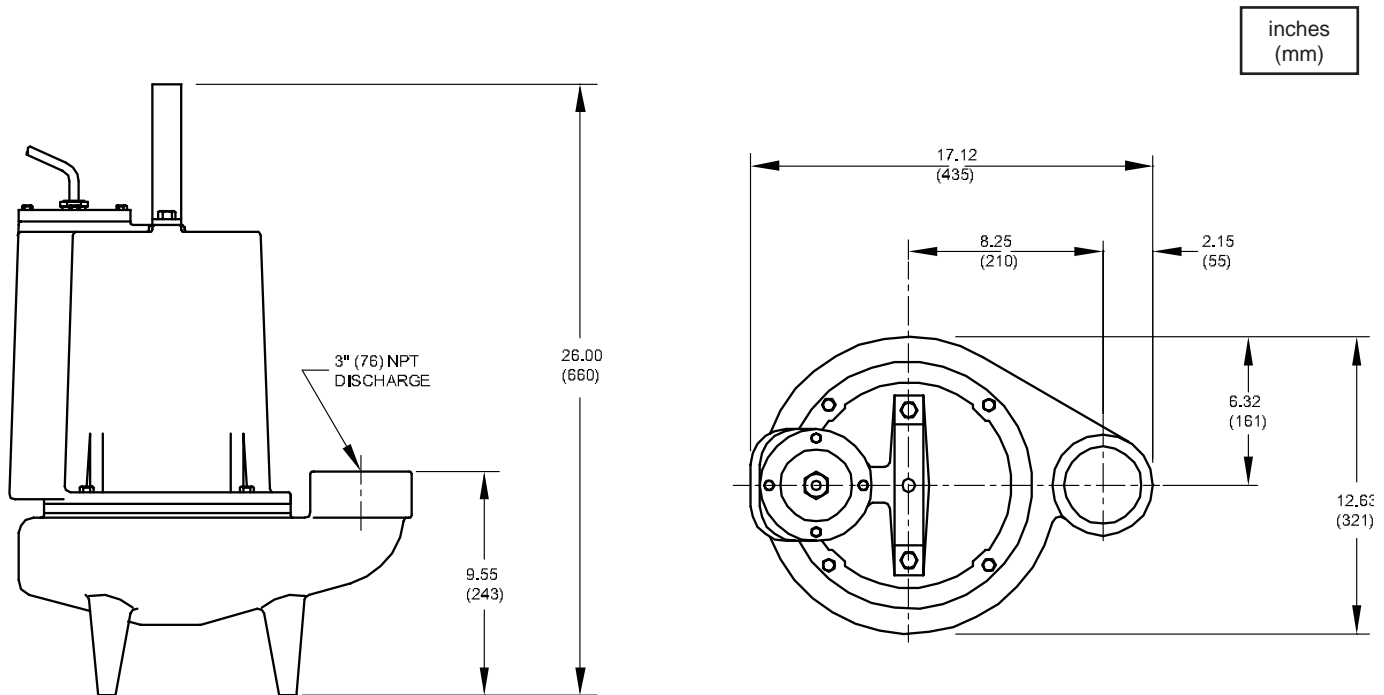

IMPORTANT !

- 1.) **DO NOT USE TO PUMP FLAMMABLE LIQUIDS.**
- 2.) INSTALLATIONS SUCH AS DECORATIVE FOUNTAINS OR WATER FEATURES PROVIDED FOR VISUAL ENJOYMENT MUST BE INSTALLED IN ACCORDANCE WITH THE NATIONAL ELECTRIC CODE ANSI/NFPA 70 AND/OR THE AUTHORITY HAVING JURISDICTION. THIS PUMP IS NOT INTENDED FOR USE IN SWIMMING POOLS, RECREATIONAL WATER PARKS, OR INSTALLATIONS IN WHICH HUMAN CONTACT WITH PUMPED MEDIA IS A COMMON OCCURRENCE.

SECTION B: GENERAL INFORMATION

B-1) To the Purchaser:

Congratulations! You are the owner of one of the finest pumps on the market today. CP&S pumps are products engineered and manufactured of high quality components. Over one hundred years of pump building experience along with a continuing quality assurance program combine to produce a pump which will stand up to the toughest applications.

This manual will provide helpful information concerning installation, maintenance, and proper service guidelines.

B-2) Receiving:

Upon receiving the pump, it should be inspected for damage or shortages. If damage has occurred, file a claim immediately with the company that delivered the pump. If the manual is removed from the packaging, do not lose or misplace.

B-3) Storage:

Short Term - CP&S Pumps are manufactured for efficient performance following short inoperative periods in storage. For best results, pumps can be retained in storage, as factory assembled, in a dry atmosphere with constant temperatures for up to six (6) months.

Long Term - Any length of time exceeding six (6) months, but not more than twenty-four (24) months. The unit should be stored in a temperature controlled area, a roofed over walled enclosure that provides protection from the elements (rain, snow, wind-blown dust, etc.), and whose temperature can be maintained between +40 deg. F and +120 deg. F. (4.4 - 49°C).

Pump should be stored in its original shipping container. On initial start up, rotate impeller by hand to assure seal and impeller rotate freely. If it is required that the pump be installed and tested before the long term storage begins, such installation will be allowed provided:

- 1.) The pump is not installed under water for more than one (1) month.
- 2.) Immediately upon satisfactory completion of the test, the pump is removed, thoroughly dried, repacked in the original shipping container, and placed in a temperature controlled storage area.

B-4) Service Centers:

For the location of the nearest Barnes Center, check your Barnes representative or Crane Pumps & Systems, Inc., Service Department in Piqua, Ohio, telephone (937) 778-8947 or Crane Pumps & Systems Canada, in Brampton, Ontario, (905) 457-6223.

SECTION C: INSTALLATION

C-1) Location:

These pumping units are self-contained and are recommended for use in a sump, lift station or basin. The sump, lift station or basin shall be vented in accordance with local plumbing codes.

This pump is designed to pump sewage, effluent, or other nonexplosive or noncorrosive wastewater and shall **NOT** be installed in locations classified as hazardous in accordance with the National Electrical Code (NEC), ANSI/NFPA 70 or the Canadian Electrical Code (CEC). Never install the pump in a trench, ditch or hole with a dirt bottom; the legs will sink into the dirt and the suction will become plugged.

C-1.1) Submergence:

It is recommended that the pump be operated in the submerged condition and the sump liquid level should never be less than dimension "A" in Fig. 1.

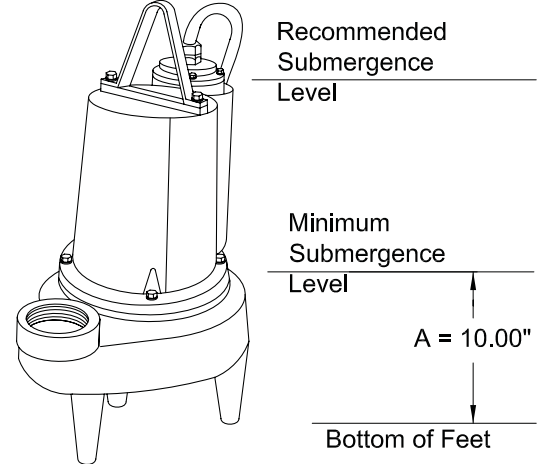

FIGURE 1

C-2) Discharge:

Discharge piping should be as short as possible. Both a check valve and a shut-off valve are recommended for each pump being used. The check valve is used to prevent backflow into the sump. Excessive backflow can cause flooding and/or damage to the pump. The shut-off valve is used to stop system flow during pump or check valve servicing.

C-3) Liquid Level Controls (Not supplied with pump):

The level controls are to be supported by a mounting bracket that is attached to the sump wall, cover or junction box. Cord grips are used to hold the cords in place on the mounting bracket. The control level can be changed by loosening the grip and adjusting the cord length as per the plans and specifications. Be certain that the level controls cannot hang up or foul in its swing and that the pump is completely submerged when the level control is in the "OFF" mode.

C-4) Electrical Connections:

C-4.1) Power/Control Cable:

The cord assembly mounted to the pump must not be modified in any way except for shortening to a specific application. Any splice between the pump and the control panel must be made in accordance with all applicable electric codes. It is recommended that a junction box, if used, be mounted outside the sump or be of at least Nema 4 (EEMAC-4) construction if located within the wet well. Do not use the power/control cable to lift pump. **NOTE: The white wire is NOT a neutral or ground lead, but a power carrying conductor.**

C-4.2) Overload Protection:

Single Phase - The type of in-winding overload protector used is referred to as an inherent overheating protector and operates on the combined effect of temperature and current. This means that the overload protector will trip out and shut the pump off if the windings become too hot, or the load current passing through them becomes too high. It will then automatically reset and start the pump up after the motor cools to a safe temperature. In the event of an overload, the source of this condition should be determined and rectified immediately. **DO NOT LET THE PUMP CYCLE OR RUN IF AN OVERLOAD CONDITION OCCURS !**

If current through the temperature sensor exceeds the values listed, an intermediate control circuit relay must be used to reduce the current or the sensor will not work properly.

TEMPERATURE SENSOR ELECTRICAL RATINGS		
Volts	Continuous Amperes	Inrush Amperes
220-240	1.50	15.0

C-4.3) Wire Size:

Consult a qualified electrician for proper wire size if additional power cable length is required. See table for electrical information.

SECTION: D START-UP OPERATION

D-1) Check Voltage and Phase:

Before operating pump, compare the voltage and phase information stamped on the pump identification plate to the available power.

D-2) Check Pump Rotation:

Before putting pump into service for the first time, the motor rotation must be checked. Improper motor rotation can result in poor pump performance and can damage the motor and/or pump. To check the rotation, suspend the pump freely, momentarily apply power and observe the “kickback”. “Kickback” should always be in a counter-clockwise direction as viewed from the top of the pump motor housing.

D-2.1) Incorrect Rotation for Single-Phase Pumps:

In the unlikely event that the rotation is incorrect for a single phase pump, contact a Barnes Service Center.

D-3) Start-Up Report:

Included at the end of this manual is a start-up report sheet, this sheet is to be completed as applicable. Return one copy to Barnes and store the second in the control panel or with the pump manual if no control panel is used. It is important to record this data at initial start-up since it will be useful to refer to should servicing the pump be required in the future.

D-3.1) Identification Plate:

Record the numbers from the pump identification plate on both START-UP REPORTS provided at the end of the manual for future reference.

D-3.2) Insulation Test:

Before the pump is put into service, an insulation (megger) test should be performed on the motor. The resistance values (ohms) as well as the voltage (volts) and current (amps) should be recorded on the start-up report.

D-3.3) Pump-Down Test:

After the pump has been properly wired and lowered into the basin, sump or lift station, it is advisable to check the system by filling with liquid and allowing the pump to operate through its pumping cycle. The time needed to empty the system, or pump-down time along with the volume of water, should be recorded on the start-up report.

SECTION E: PREVENTATIVE MAINTENANCE

As the motor is oil filled, no lubrication or other maintenance is required, and generally Barnes pumps will give very reliable service and can be expected to operate for years on normal sewage pumping without failing. However as with any mechanical piece of equipment a preventive maintenance program is recommended and suggested to include the following checks:

- 1) Inspect motor chamber for oil level and contamination and repair as required per section F-1.
- 2) Inspect impeller and body for excessive build-up or clogging and repair as required per section F-2.
- 3) Inspect motor, bearings and shaft seal for wear or leakage, replace as required per section F-3.

MODEL NO	HP	VOLT	PH/Hz	RPM (Nom)	NEMA START CODE	FULL LOAD AMPS	LOCKED ROTOR AMPS	CORD SIZE	CODE TYPE	CORD O.D. ± .02 (.5) in (mm)	WINDING RESISTANCE MAIN -- START
3SF3024L	3.0	230	1 / 60	1750	A	28.0	59.0	10/3	SOW	0.69 (17.5)	0.84 -- 4.0

Winding Resistance ± 5%, measured from terminal block.
Pump rated for operation at ± 10% voltage at motor.

SECTION F: SERVICE AND REPAIR

NOTE: All item numbers in () refer to Figures 8 & 9.

F-1) Lubrication:

Anytime the pump is removed from operation the cooling oil in the motor housing (2) must be checked visually for oil level and contamination.

F-1.1) Checking Oil:

Motor Housing - To check oil, set unit upright. Remove cap screws (6) and lockwashers (4), lift cord grip plate (10j) from motor housing (2) but **DO NOT** disconnect from motor leads. With a flashlight, visually inspect the oil in the motor housing (2) to make sure it is clean, clear and that oil level is above all internal componentry.

F-1.2) Testing Oil:

1. Place pump on it's side, remove cap screws (6) and lockwashers (4), lift cord grip plate (10j) from motor housing (2) and drain oil into a clean, dry container.
2. Check oil for contamination using an oil tester with a range to 30 Kilovolts breakdown.
3. If oil is found to be clean and uncontaminated (measure above 15 KV. breakdown), refill the motor housing as per section F-1.3.
4. If oil is found to be dirty or contaminated (or measures below 15 KV. breakdown), the the pump must be carefully inspected for leaks at the shaft seal (46), cord grip plate (10j), O-rings (11) and (42) pipe plug (5) before refilling with oil. To locate the leak, perform a pressure test as per section F-1.4. After leak is repaired, refill with new oil as per section F-1.3.

F-1.3) Replacing Oil:

Motor Housing - Drain all oil from motor housing and dispose of properly. Refill with (see parts list for amount) new cooling oil as per Table 1. An air space must remain in the top of the motor housing to compensate for oil expansion (See Figure 8). Set unit upright and fill only until the motor, as viewed through the conduit box opening, is just covered and no more.

Reassemble the O-ring (11), cord grip plate (10j), cap screws (6) and lockwashers (4), apply thread locking compound to each cap screw (6) thread before installing. Torque cap screws (6) to 15 ft., lbs.

TABLE 1 - COOLING OIL - Dielectric	
SUPPLIER	GRADE
BP	Enerpar SE100
Conoco	Pale Paraffin 22
Mobile	D.T.E. Oil Light
G & G Oil	Circulating 22
Imperial Oil	Voltesso-35
Shell Canada	Transformer-10
Texaco	Diala-Oil-AX
Woco	Premium 100

WARNING ! - DO NOT overfill oil . Overfilling of motor housing with oil can create excessive and dangerous hydraulic pressure which can destroy the pump and create a hazard. Overfilling oil voids warranty.



F-1.4) Pressure Test:

Motor Housing - Before checking the pump for leaks around the shaft seal, o-rings, and cord inlet, the oil level should be full as described in section F-1.3. Remove pipe plug (5) and lifting handle (7) from motor housing (2). Apply pipe sealant to pressure gauge assembly and tighten into pipe plug hole (see Figure 2). Pressurize motor housing to 10 P.S.I. Use a soap solution around the sealed areas and inspect joints for "air bubbles". If, after five minutes, the pressure is still holding constant, and no "bubbles" are observed, slowly bleed the pressure and remove the gauge assembly. Replace the pipe plug using a sealant. If the pressure does not hold, then the leak must be located.

CAUTION ! - Pressure builds up extremely fast, increase pressure by "tapping" air nozzle. Too much pressure will damage seal. DO NOT exceed 10 P.S.I. in motor housing

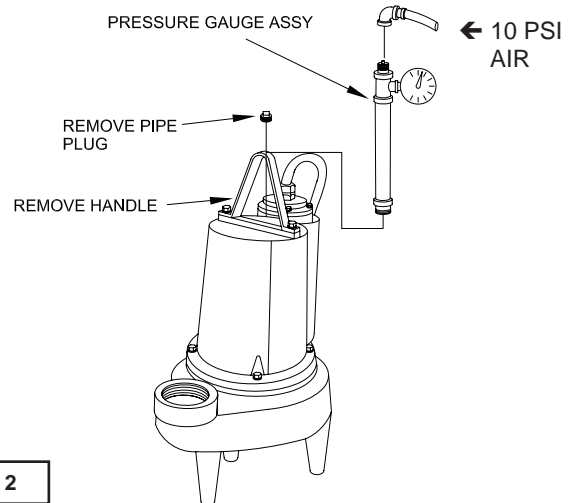

FIGURE 2

F-2) Impeller and Volute Service:

F-2.1) Disassembly and Inspection:

To clean out volute (26), disconnect power, remove hex nuts (20) and lockwashers (19), vertically lift motor and seal assembly from volute (26). Clean out body if necessary. Clean and examine impeller (28) for pitting or wear, replace if required. Inspect square ring (42) and replace if cut or damaged. If impeller (28) requires replacing, remove jam nut (34) and washer (35), by placing a flat screwdriver in the slot of the end of the shaft to hold the shaft stationary while unscrewing the impeller (28). Once impeller (28) is removed, remove pull washer (16) and exclusion seal (17) if damaged or cut.

F-2.2) Reassembly:

Position exclusion seal (17) on shaft until it seats against the stationary portion of seal (46). Place pull washer (16) on shaft until it seats against exclusion seal (17). To install impeller (28), clean the threads with loctite cleaner and screw impeller (28) onto the shaft hand tight. Apply thread locking compound to shaft threads and install washer (35) and jam nut (34). Torque to 40 ft. lbs. Rotate impeller to check for binding.

Position o-ring (42) on volute flange and position impeller and motor housing assembly over studs and onto volute (26). Apply thread locking compound to each stud (24). Place lockwasher (19) and hex nut (20) onto studs (24) and torque to 24 ft. lbs. Check for free rotation of motor and impeller.

F-3) Motor, Bearing and Seal Service

F-3.1) Disassembly and Inspection:

To examine or replace the motor (1), bearing (47) and shaft seal (46), disassemble volute and impeller as outlined in paragraph F-2.1. Drain oil from motor as outlined in paragraph F-1.3.

Position unit upright, using blocks to avoid resting unit on shaft. After removal of cord grip plate (10j), per paragraph F-1.3, from motor housing (2) remove cable lead wires from motor lead wires by disconnecting wire connectors (12). Also disconnect ground screw (18) from motor (1). The wiring connections should be noted to insure correct connections when reassembling.

Motor - Remove the motor bolts and lift motor stator from motor rotor and seal plate (25). Unscrew conduit bushing (14) from seal plate (25) and lift motor rotor, shaft, bearing (42), rotating portion of seal (46b), washer (9) and conduit bushing (14) from seal plate (25).

Check motor capacitor (3, single phase units) with an Ohm meter by first grounding the capacitor by placing a screwdriver across both terminals and then removing screwdriver. Connect Ohm meter (set on high scale) to terminals. If needle moves to infinity (∞) then drifts back, the capacitor is good. If needle does not move or moves to infinity (∞) and does not drift back, replace capacitor (3). Inspect motor winding for shorts and check resistance values. Check rotor for wear. If rotor or the stator windings are defective, the complete motor must be replaced.



CAUTION ! - Handle seal parts with extreme care. DO NOT scratch or mar lapped surfaces.

Seal - Remove rotating member (46a), spring (46c) and retaining ring (46d) from shaft. (See Figure 3). Examine all seal parts and especially contact faces. Inspect seal for signs of wear such as uneven wear pattern on stationary members, chips and scratches on either seal face. **DO NOT interchange seal components**, replace the entire shaft seal (46). If replacing seal, remove stationary (46a) from seal plate (25) by prying out with flat screwdriver.

Bearing - Examine bearing (47) and replace if required. If replacement is required, remove bearing (47) from motor shaft using a wheel puller. Washer (9), retaining ring (30) and conduit bushing (14) can now be removed from motor shaft.



IMPORTANT ! - All parts must be clean before reassembly.

F-3.2) Reassembly:

Bearing - When replacing bearing, be careful not to damage the rotor or shaft threads. Clean the shaft thoroughly. Slide conduit bushing (14) and washer (9) over motor shaft. Insert retaining ring (30) into groove on shaft. Apply adhesive compound to the shaft and press bearing (47) on the motor shaft, position squarely onto shaft applying force to the inner race of the bearing only, until bearing seats against retaining ring (30).

Seal - Clean and oil seal cavity in seal plate (25). Press stationary member (46a) firmly into seal plate (25), using a seal pusher, nothing but the seal pusher is to come in contact with seal face (See Figure 4). Make sure the stationary member is in straight.

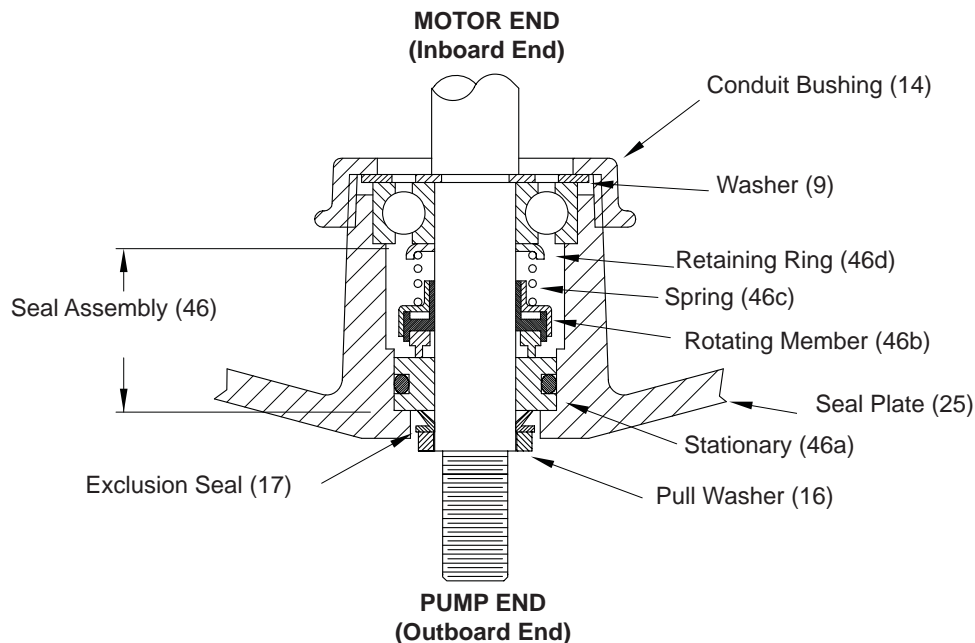

FIGURE 3

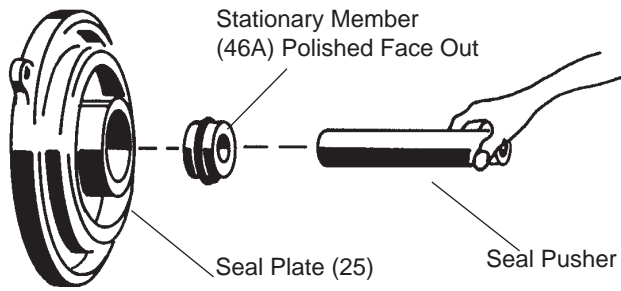

FIGURE 4

IMPORTANT! - DO NOT hammer on the seal pusher- it will damage the seal face.

Slide retaining ring (46d) over shaft and let rest on bearing (47). Place spring (46c) over shaft and let rest on retaining ring (46d). Lightly oil (**DO NOT use grease**) shaft, bullet and inner surface of bellows on rotating member (46b), (See Figure 5), with lapped surface of rotating member (46b) facing outward, slide over bullet and onto shaft using seal pusher, making sure spring (46c) is seated in retaining ring (46d) and spring (46c) is lined up on rotating member (46b) and not cocked or resting on bellows tail.

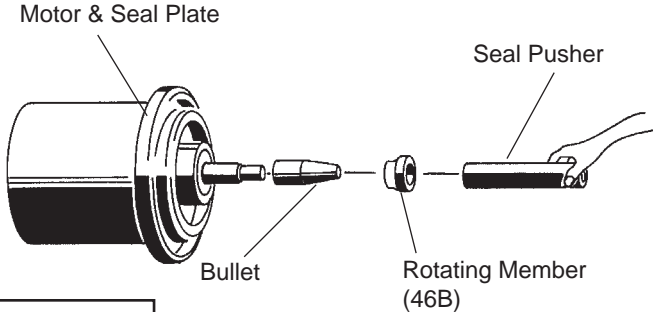

FIGURE 5

IMPORTANT! - it is extremely important to keep seal faces clean during assembly. Dirt particles lodged between these faces will cause the seal to leak.

Motor - Slide motor rotor with conduit bushing (14), washer (9), bearing (47) and seal parts (46b, c, d) into seal plate (25) until bearing (47) seats in seal plate (25). Center washer (9) on bearing (47) and tighten conduit bushing (14) on seal plate (25). Lower motor stator over rotor until seated in seal plate (25), while aligning holes for motor bolts. Insert motor bolts and torque to 17 inch pounds. Place bracket (15) on one of the motor bolts. Insert capacitor (3) in bracket (15), attach motor leads with terminals to capacitor and place terminal boot (27) over terminals.

Place all motor leads above motor. Position o-ring (42) on seal plate (25) and lower motor housing (2) over motor and into pilot. Place socket head cap screws (39) through seal plate (25) into motor housing (2) and torque to 60 inch pounds. Make wire connections per paragraph F-3.3. Assemble impeller and volute per paragraph F-2.2.

F-3.3) Wiring Connections:

Check power cable (10A) on cord grip plate (10j), for cracks or damage and replace if required (See Figure 6). Bring motor wires through wire opening in top of housing (2), position square ring (11) in cord grip plate (10j) and reconnect motor leads to power cable using connectors (12) as show in Figure 7.

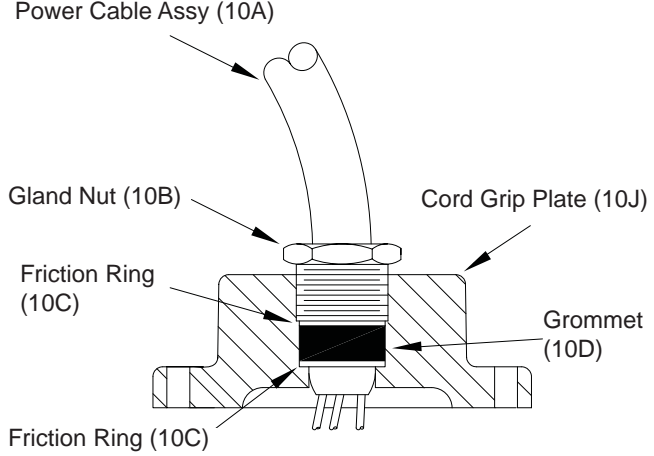

FIGURE 6

**Single Phase, 240 VOLT AC (PSC)
Models 3SF3024L**

Green (Ground)	Green
Black	1
White	2
Flag connector	Capacitor
Flag connector	Capacitor

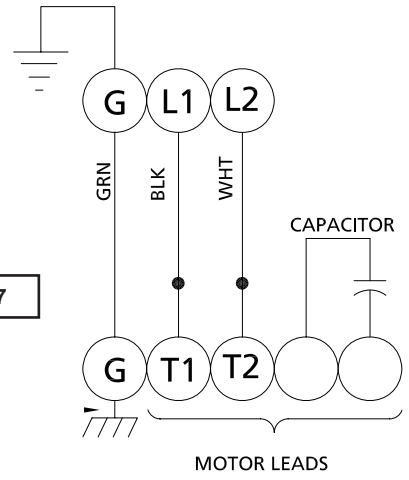

FIGURE 7

F-3.4) Cord Grip Plate Assembly:

Refill with cooling oil as outlined in paragraph F-1.3. Position cord grip plate (10j) and square ring (11) over opening. Place lockwashers (4) on cap screws (6), apply thread locking compound to cap screws (6) threads and torque to 16 ft lbs. Remove gland nut (10B), friction rings (10C), and grommet (10D) from cord grip plate (10J) inspect and replace if required (see Figures 6).

Insert one friction ring (10C), grommet (10D), one friction ring (10C) and gland nut (10B) into cord grip plate (10J) for power cable (10A). Torque gland nut (10B) to 15 ft. lbs to prevent water leakage.

SECTION: G REPLACEMENT PARTS

G-1 ORDERING REPLACEMENT PARTS:

When ordering replacement parts, ALWAYS furnish the following information:

1. Pump serial number and date code. (Paragraph G-4)
2. Pump model number. (Paragraph G-3)
3. Pump part number. (Paragraph G-2)
4. Part description.
5. Item part number.
6. Quantity required.
7. Shipping instructions.
8. Billing Instructions.

BARNES	HP.	Volts	Code	Ph.	Hz.
	RPM	FLA	Model No.	2	
	Part No.	3	Serial No.	1	
	Impeller Dia.	Max. Liq. Temp. °C	Ins. Class		

WARNING TO REDUCE RISK OF ELECTRICAL SHOCK DISCONNECT THE PUMP FROM THE POWER SOURCE BEFORE HANDLING OR SERVICING. SEE INSTRUCTION MANUAL FOR PROPER INSTALLATION. SEE WARNING PLATE FOR ADDITIONAL CAUTIONS.

G-3 MODEL NUMBER:

This designation consists of numbers and letters which represent the discharge size, series, horsepower, motor phase and voltage, speed and pump design. This number is used for ordering and obtaining information.

G-4 SERIAL NUMBER:

The serial number block will consist of a six digit number, which is specific to each pump and may be preceded by an alpha character, which indicates the plant location. This number will also be suffixed with a four digit number, which indicates the date the unit was built (Date Code). **EXAMPLE: A012345 0490.**

Reference the six digit portion (Serial Number) of this number when referring to the product.

G-2 PART NUMBER:

The part number consists of a six (6) digit number, which appears in the catalog. A one or two letter suffix may follow this number to designate the design configuration. This number is used for ordering and obtaining information.

IMPORTANT! WARRANTY REGISTRATION

Your product is covered by the enclosed Warranty. Complete the Warranty Registration Form and return to Crane Pumps & Systems, Inc. Warranty Service Group If you have a claim under the provision of the warranty, contact your local Crane Pumps & Systems, Inc. Distributor.

**RETURNED GOODS
RETURN OF MERCHANDISE REQUIRES A "RETURNED GOODS AUTHORIZATION".
CONTACT YOUR LOCAL CRANE PUMPS & SYSTEMS, INC. DISTRIBUTOR.**



Products Returned Must Be Cleaned, Sanitized, Or Decontaminated As Necessary Prior To Shipment, To Insure That Employees Will Not Be Exposed To Health Hazards In Handling Said Material. All Applicable Laws And Regulations Shall Apply.

TROUBLE SHOOTING

CAUTION ! Always disconnect the pump from the electrical power source before handling.
 If the system fails to operate properly, carefully read instructions and perform maintenance recommendations.
 If operating problems persist, the following chart may be of assistance in identifying and correcting them:
 MATCH "CAUSE" NUMBER WITH CORRELATING "CORRECTION" NUMBER.

NOTE: Not all problems and corrections will apply to each pump model.

PROBLEM	CAUSE	CORRECTION
Pump will not run	<ol style="list-style-type: none"> 1. Poor electrical connection, blown fuse, tripped breaker or other interruption of power, improper power supply. 2. Motor or switch inoperative (to isolate cause, go to manual operation of pump). <ol style="list-style-type: none"> 2a. Float movement restricted. 2b. Switch will not activate pump or is defective. 3. Insufficient liquid level. 	<ol style="list-style-type: none"> 1. Check all electrical connections for security. Have electrician measure current in motor leads, if current is within $\pm 20\%$ of locked rotor Amps, impeller is probably locked. If current is 0, overload may be tripped. Remove power, allow pump to cool, then recheck current. 2a. Reposition pump or clean basin as required to provide adequate clearance for float. 2b. Disconnect level control. Set ohmmeter for a low range, such as 100 ohms full scale and connect to level control leads. Actuate level control manually and check to see that ohmmeter shows zero ohms for closed switch and full scale for open switch. (Float Switch). 2c. Check winding insulation (Megger Test) and winding resistance. If check is outside of range, dry and recheck. If still defective, replace per service instructions. 3. Make sure liquid level is at least equal to suggested turn-on point.
Pump will not turn off	<ol style="list-style-type: none"> 2a. Float movement restricted. 2b. Switch will not activate pump or is defective. 4. Excessive inflow or pump not properly sized for application. 9. Pump may be airlocked. 14. H-O-A switch on panel is in "HAND" position 	<ol style="list-style-type: none"> 2c. Check winding insulation (Megger Test) and winding resistance. If check is outside of range, dry and recheck. If still defective, replace per service instructions. 3. Make sure liquid level is at least equal to suggested turn-on point. 4. Recheck all sizing calculations to determine proper pump size. 5. Check discharge line for restrictions, including ice if line passes through or into cold areas. 6. Remove and examine check valve for proper installation and freedom of operation. 7. Open valve. 8. Check cutter for freedom of operation, security and condition. Clean cutter and inlet of any obstruction. 9. Loosen union slightly to allow trapped air to escape. Verify that turn-off level of switch is set so that the suction is always flooded. Clean vent hole.
Pump hums but does not run	<ol style="list-style-type: none"> 1. Incorrect voltage 8. Impeller jammed or loose on shaft, worn or damaged, impeller cavity or inlet plugged. 	<ol style="list-style-type: none"> 3. Make sure liquid level is at least equal to suggested turn-on point. 4. Recheck all sizing calculations to determine proper pump size. 5. Check discharge line for restrictions, including ice if line passes through or into cold areas. 6. Remove and examine check valve for proper installation and freedom of operation. 7. Open valve. 8. Check cutter for freedom of operation, security and condition. Clean cutter and inlet of any obstruction. 9. Loosen union slightly to allow trapped air to escape. Verify that turn-off level of switch is set so that the suction is always flooded. Clean vent hole.
Pump delivers insufficient capacity	<ol style="list-style-type: none"> 1. Incorrect voltage. 4. Excessive inflow or pump not properly sized for application. 5. Discharge restricted. 6. Check valve stuck closed or installed backwards. 7. Shut-off valve closed. 8. Impeller jammed or loose on shaft, worn or damaged, impeller cavity or inlet plugged. 9. Pump may be airlocked. 10. Pump stator damaged/torn. 	<ol style="list-style-type: none"> 4. Recheck all sizing calculations to determine proper pump size. 5. Check discharge line for restrictions, including ice if line passes through or into cold areas. 6. Remove and examine check valve for proper installation and freedom of operation. 7. Open valve. 8. Check cutter for freedom of operation, security and condition. Clean cutter and inlet of any obstruction. 9. Loosen union slightly to allow trapped air to escape. Verify that turn-off level of switch is set so that the suction is always flooded. Clean vent hole. 10. Check rotation. If power supply is three phase, reverse any two of three power supply leads to ensure proper impeller rotation. 11. Repair fixtures as required to eliminate leakage. 12. Check pump temperature limits & fluid temperature.
Pump cycles too frequently or runs periodically when fixtures are not in use	<ol style="list-style-type: none"> 6. Check valve stuck closed or installed backwards. 11. Fixtures are leaking. 15. Ground water entering basin. 	<ol style="list-style-type: none"> 10. Check rotation. If power supply is three phase, reverse any two of three power supply leads to ensure proper impeller rotation. 11. Repair fixtures as required to eliminate leakage. 12. Check pump temperature limits & fluid temperature. 13. Replace portion of discharge pipe with flexible connector. 14. Turn to automatic position. 15. Check for leaks around basin inlet and outlets.
Pump shuts off and turns on independent of switch, (trips thermal overload protector). CAUTION! Pump may start unexpectedly. Disconnect power supply.	<ol style="list-style-type: none"> 1. Incorrect voltage. 4. Excessive inflow or pump not properly sized for application. 8. Impeller jammed or loose on shaft, worn or damaged, impeller cavity or inlet plugged 12. Excessive water temperature (Internal protection only). 	<ol style="list-style-type: none"> 10. Check rotation. If power supply is three phase, reverse any two of three power supply leads to ensure proper impeller rotation. 11. Repair fixtures as required to eliminate leakage. 12. Check pump temperature limits & fluid temperature. 13. Replace portion of discharge pipe with flexible connector. 14. Turn to automatic position. 15. Check for leaks around basin inlet and outlets.
Pump operates noisily or vibrates excessively	<ol style="list-style-type: none"> 2c. Worn bearings, motor shaft bent 8. Debris in impeller cavity or broken impeller. 10. Pump running backwards. 13. Piping attachments to building structure too rigid or too loose. 	<ol style="list-style-type: none"> 13. Replace portion of discharge pipe with flexible connector. 14. Turn to automatic position. 15. Check for leaks around basin inlet and outlets.

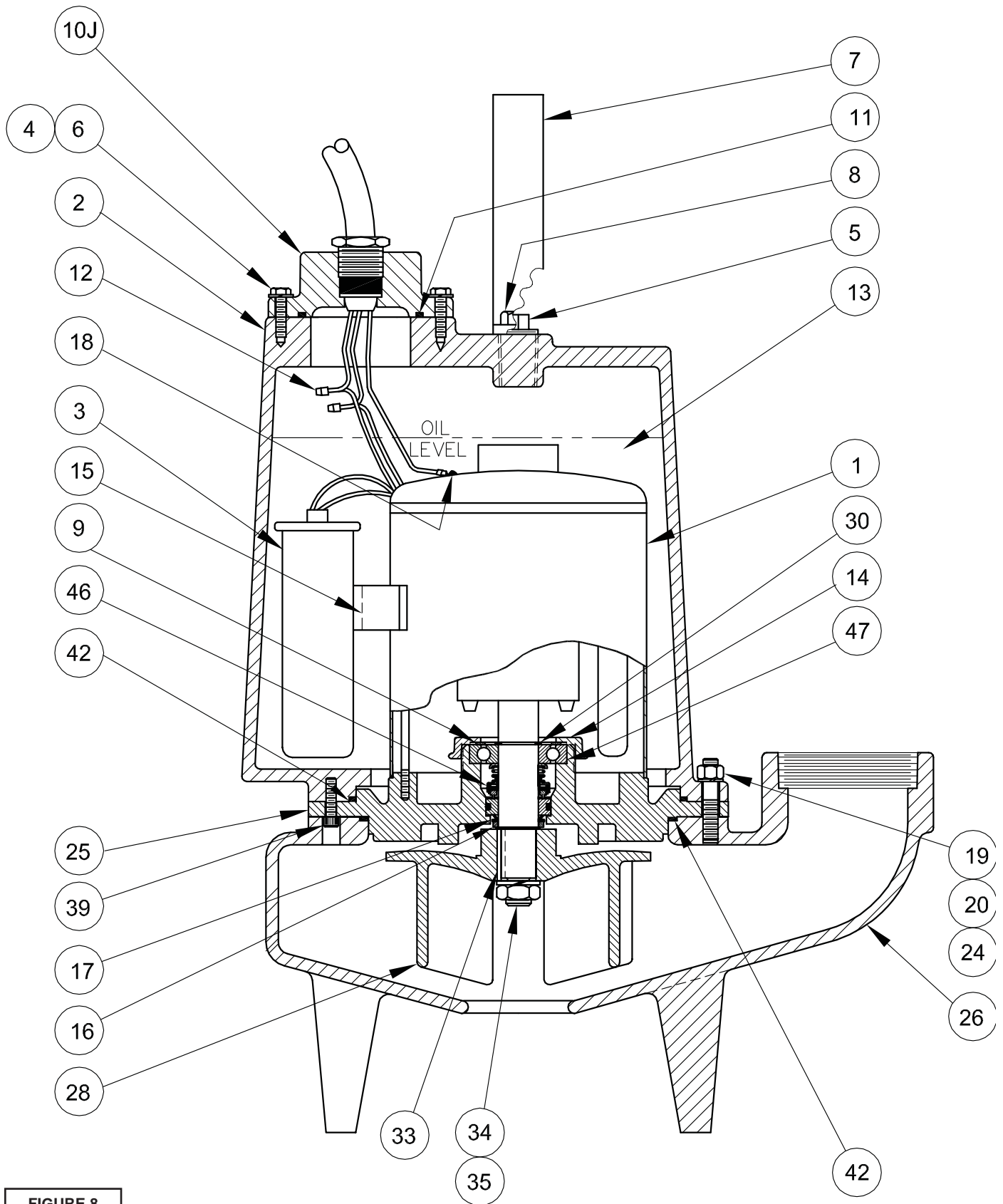

FIGURE 8

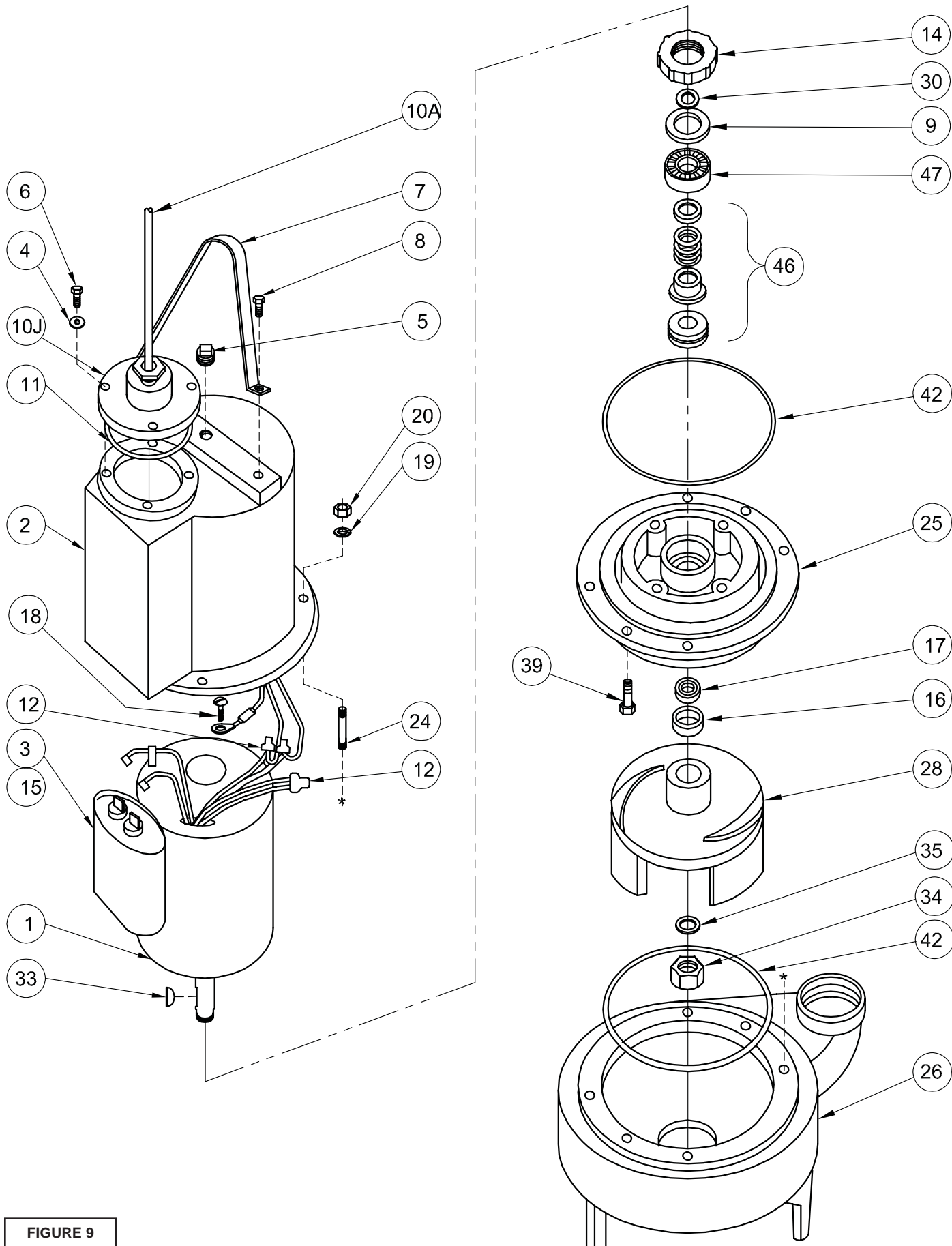

FIGURE 9

PARTS LIST

ITEM	QTY	PART NO.	DESCRIPTION
1	1	088700	Motor 3SF3024L
2	1	053154	Motor Housing
3	1	036391	Capacitor, 3HP 370v, 45MFD
4	4	20-13-1	Lockwasher 1/4" Stainless
5	1	003204	Pipe Plug
6	4	1-7-1	Cap Screw 1/4-20 x 1" Lg Stainless
7	1	036754	Lifting Strap
8	2	1-65-1	Cap Screw 1/2-13 x 7/8" Lg Steel
9	1	053756	Washer 1.875 x 2.625 Steel
10	1	See Table 3	* Cord Grip Plate Assembly
10a	1	085399XB	* Power Cable 1 Phase - 25 Ft.
10b	1	051447	* Gland Nut
10c	2	066071	* Friction Ring 1 Phase
10d	1	066072	* Grommet 1 Phase
10j	1	053156	* Cord Grip Plate
11	1	017026	Square Ring
12	3	079318	Wire Connector 1 Phase
13	1-1/2 Gal.	029034	Oil- Motor Housing
14	1	053749	Conduit Bushing
15	1	033459	Bracket, Capacitor
16	1	062641	Pull Washer
17	1	061829	Exclusion Seal
18	1	038156	Pan Hd Screw 6-32 x .375
19	4	20-14-1	Lockwasher 3/8" Stainless
20	4	15-23-1	Hex Nut 3/8-16 Stainless
24	4	002420	Stud 3/8-16 x 2.00" Lg Stainless
25	1	062482	Seal Plate
26	1	062640	Volute
27	1	034322	Terminal Boot, 1 Phase
28	1	088534	Impeller, Cast Iron 7.50" Dia. (3HP-STD)
		088534TA	7.38" Dia.
		088534TB	7.25" Dia.
		088534TC	7.12" Dia.
		088534TD	7.00" Dia.
		088534TE	6.88" Dia.
		088534TF	6.75" Dia.
		088534TG	6.62" Dia.
		088534TH	6.50" Dia.
		088534TJ	6.38" Dia.
		088534TK	6.25" Dia.
		088534TL	6.12" Dia.
		088534TM	6.00" Dia.
		088534TN	5.88" Dia.
		088534TP	5.75" Dia.
		088534TQ	5.62" Dia.
30	1	057882	Retaining Ring
33	1	035589	Shaft Key #61 x .187
34	1	038132	Hex Nut 5/8-18 Stainless
35	1	20-24-1	Washer 5/8-18 Stainless
39	2	11-32-1	Soc. Hd. Cap Screw 1/4-20 x 1.00" Lg Stainless
42	2	033730	O-Ring
46	1	062435	Shaft Seal - Carbon/Ceramic/Buna-N (STD)
		062435SB	Tungsten/Tungsten/Buna-N
		062435SD	Silicon/Silicon/Buna-N
		062435SF	Carbon/Ceramic/Viton
		062435SH	Tungsten/Tungsten/Viton
		062435SK	Silicon/Silicon/Viton
		062435SM	Silicon/Tungsten/Buna-N
		062435SN	Carbon/Ni-Resist/Buna-N
		062435SP	Carbon/Ni-Resist/Neoprene
47	1	053746	Ball Bearing

TABLE 3 - POWER CORD SET

LENGTH	ITEM #10A
15 Ft	085399
20 Ft	085399XA
25 Ft	085399XB
30 Ft	085399XC
35 Ft	085399XD
40 Ft	085399XE
50 Ft	085399XF
60 Ft	085399XG
70 Ft	085399XH
80 Ft	085399XJ
90 Ft	085399XK
100 Ft	085399XL
150 Ft	085399XS
200 Ft	085399XY

(*) Supplied with Item #10

BARNES®

BARNES®
PRESSURE PS SYSTEMS

CROWN

burks®

WEINMAN®

DEMING®

PROSSER®

Limited 24 Month Warranty

Crane Pumps & Systems warrants that products of our manufacture will be free of defects in material and workmanship under normal use and service for twenty-four (24) months after manufacture date, when installed and maintained in accordance with our instructions. This warranty gives you specific legal rights, and there may also be other rights which vary from state to state. In the event the product is covered by the Federal Consumer Product Warranties Law (1) the duration of any implied warranties associated with the product by virtue of said law is limited to the same duration as stated herein, (2) this warranty is a LIMITED WARRANTY, and (3) no claims of any nature whatsoever shall be made against us, until the ultimate consumer, his successor, or assigns, notifies us in writing of the defect, and delivers the product and/or defective part(s) freight prepaid to our factory or nearest authorized service station. Some states do not allow limitations on how long an implied warranty lasts, so the above limitation may not apply. **THE SOLE AND EXCLUSIVE REMEDY FOR BREACH OF ANY AND ALL WARRANTIES WITH RESPECT TO ANY PRODUCT SHALL BE TO REPLACE OR REPAIR AT OUR ELECTION, F.O.B. POINT OF MANUFACTURE OR AUTHORIZED REPAIR STATION, SUCH PRODUCTS AND/OR PARTS AS PROVEN DEFECTIVE. THERE SHALL BE NO FURTHER LIABILITY, WHETHER BASED ON WARRANTY, NEGLIGENCE OR OTHERWISE.** Unless expressly stated otherwise, guarantees in the nature of performance specifications furnished in addition to the foregoing material and workmanship warranties on a product manufactured by us, if any, are subject to laboratory tests corrected for field performance. Any additional guarantees, in the nature of performance specifications must be in writing and such writing must be signed by our authorized representative. Due to inaccuracies in field testing if a conflict arises between the results of field testing conducted by or for user, and laboratory tests corrected for field performance, the latter shall control. **RECOMMENDATIONS FOR SPECIAL APPLICATIONS OR THOSE RESULTING FROM SYSTEMS ANALYSES AND EVALUATIONS WE CONDUCT WILL BE BASED ON OUR BEST AVAILABLE EXPERIENCE AND PUBLISHED INDUSTRY INFORMATION. SUCH RECOMMENDATIONS DO NOT CONSTITUTE A WARRANTY OF SATISFACTORY PERFORMANCE AND NO SUCH WARRANTY IS GIVEN.**

This warranty shall not apply when damage is caused by (a) improper installation, (b) improper voltage (c) lightning (d) excessive sand or other abrasive material (e) scale or corrosion build-up due to excessive chemical content. Any modification of the original equipment will also void the warranty. We will not be responsible for loss, damage or labor cost due to interruption of service caused by defective parts. Neither will we accept charges incurred by others without our prior written approval.

This warranty is void if our inspection reveals the product was used in a manner inconsistent with normal industry practice and/or our specific recommendations. The purchaser is responsible for communication of all necessary information regarding the application and use of the product. **UNDER NO CIRCUMSTANCES WILL WE BE RESPONSIBLE FOR ANY OTHER DIRECT OR CONSEQUENTIAL DAMAGES, INCLUDING BUT NOT LIMITED TO TRAVEL EXPENSES, RENTED EQUIPMENT, OUTSIDE CONTRACTOR FEES, UNAUTHORIZED REPAIR SHOP EXPENSES, LOST PROFITS, LOST INCOME, LABOR CHARGES, DELAYS IN PRODUCTION, IDLE PRODUCTION, WHICH DAMAGES ARE CAUSED BY ANY DEFECTS IN MATERIAL AND/OR WORKMANSHIP AND/OR DAMAGE OR DELAYS IN SHIPMENT. THIS WARRANTY IS EXPRESSLY IN LIEU OF ANY OTHER EXPRESS OR IMPLIED WARRANTY, INCLUDING ANY WARRANTY OF MERCHANTABILITY OR FITNESS FOR A PARTICULAR PURPOSE.**

No rights extended under this warranty shall be assigned to any other person, whether by operation of law or otherwise, without our prior written approval.

CRANE
®

A Crane Co. Company

PUMPS & SYSTEMS

420 Third Street
Piqua, Ohio 45356
Phone: (937) 778-8947
Fax: (937) 773-7157
www.cranepumps.com

83 West Drive, Brampton
Ontario, Canada L6T 2J6
Phone: (905) 457-6223
Fax: (905) 457-2650

**IMPORTANT!
WARRANTY REGISTRATION**

Your product is covered by the enclosed Warranty.
To complete the Warranty Registration Form go to:

<http://www.cranepumps.com/ProductRegistration/>

If you have a claim under the provision of the warranty, contact your local
Crane Pumps & Systems, Inc. Distributor.

RETURNED GOODS

**RETURN OF MERCHANDISE REQUIRES A "RETURNED GOODS AUTHORIZATION".
CONTACT YOUR LOCAL CRANE PUMPS & SYSTEMS, INC. DISTRIBUTOR.**



**Products Returned Must Be Cleaned, Sanitized,
Or Decontaminated As Necessary Prior To Shipment,
To Insure That Employees Will Not Be Exposed To Health
Hazards In Handling Said Material. All Applicable Laws
And Regulations Shall Apply.**

