

LITTLE GIANT CIRCULATOR PUMP®

**OWNER'S MANUAL
FOR
CMD-100-3B
CMD-100-5B
CMD-100-5BY**

- ASSEMBLY
- INSTALLATION
- OPERATION
- REPAIR PARTS
- SAFETY

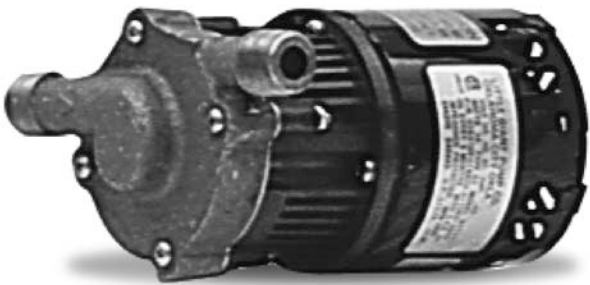

CMD-100-3B

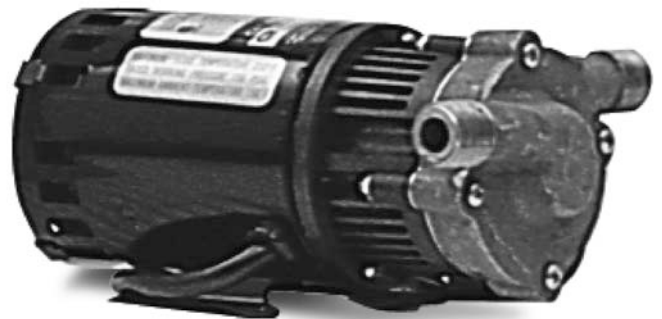

CMD-100-5B

INTRODUCTION

The Little Giant pumps are carefully packaged, inspected and tested to insure safe operation and delivery. When you receive your pump, examine it carefully to determine that there are no broken or damaged parts that may have occurred during shipment. If damage has occurred, make notation and notify the firm from which you purchased the pump. They will assist you in replacement or repair of the pump.

CMD SERIES

The CMD Series of pumps have been specifically designed for solar heat recirculation, domestic and commercial hot water loops. The CMD pumps are efficient brass booster pumps designed for water loops handling pressures to 150° PSI. Both the -3B and -5B can be used on all types of domestic solar and hydronic recirculation applications for residences, apartments or commercial usage. Pumps have brass volute, Ryton® impeller with exclusive nylon magnet design that will handle fluid temperatures to 212° F. Pumps have ½" MNPT connections and the volute can be rotated 90° intervals. The design permits servicing of motor without losing liquids or draining system. For use in nonflammable liquids compatible with pump component material.

SAFETY GUIDELINES

1. **CAUTION: To reduce the risk of electric shock, disconnect motor from power source before servicing the pump.**
2. Read all instructions and safety guidelines thoroughly. Failure to follow the guidelines and instructions could result in serious bodily injury and/or property damage.
3. Do not pump flammable liquids such as gasoline or fuel oil.
4. During operation, the area around the pump may be covered with water. Take care when handling the pump. Do not disconnect plumbing connections when pump is in operation.
5. Do not stand in water when changing fuses.

ELECTRICAL CONNECTIONS

1. If the pump is supplied with a three prong electrical plug, the third prong is to ground the motor to prevent possible electrical shock hazard. Do not remove the third prong from the plug. The receptacle should be the three prong polarized type with an internal ground. A separate branch circuit is recommended. Do not use an extension cord. Do not cut plug from cord, this will void the warranty.
2. If the motor has either individual lead wires and conduit connection box, or power cord with stripped lead wires, be sure that the wires are connected to proper power supply source. Use the conduit box on motor (if applicable) to connect conduit pipe to protect individual lead wires. Color code will either be: black: (live) white (common) green (ground) or brown (live) blue (common) green/yellow (ground).

IMPORTANT – Read pump label for correct voltage of pump motor. Make sure proper voltage is supplied to motor.

SERVICE

Very little service is required by the CMD-100 pumps. Sleeve bearing motors require lubrication once a year at the beginning of the season using an SAE 20 weight non detergent oil. If the pump is to be used year round; it should be oiled every six months. Do not over oil. Three or four drops should be sufficient. No lubrication is necessary for ball bearing motor models. Position motor so oiler tubes are located on upper portion of motor.

The circulator pump is comprised of two main sections, (1) the pumping head and (2) the drive motor. The pumping head includes: the volute, thrust bearing, impeller shaft, o-ring seal, impeller assembly, stainless steel backplate and housing. The drive motor includes the motor and the drive magnet assembly. To separate the two sections, remove the three screws which attach the pump head to the motor. Only three screws have been used by the factory to permit easy assembly and disassembly. Liquid will still be contained on the pumping head, and will not be drained unless you loosen the four screws that attach the brass volute to the housing. The pump head must be realigned on the motor drive assembly before the pump is put back into service.

CMD-100-3B

- 1550 RPM MOTOR
- BRASS PUMP HEAD
- CONDUIT BOX
- DUAL FAN
- 15" LEAD WIRES

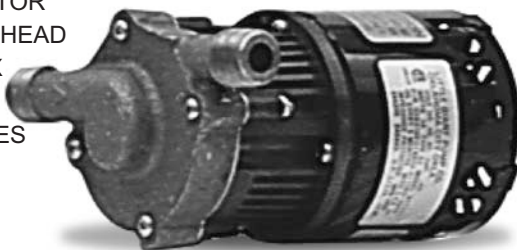

CMD-100-5B

- 3000 RPM MOTOR
- BRASS PUMP HEAD
- BASE BRACKET
- DUAL FAN
- 6 FT. SJT CORD ON 115V

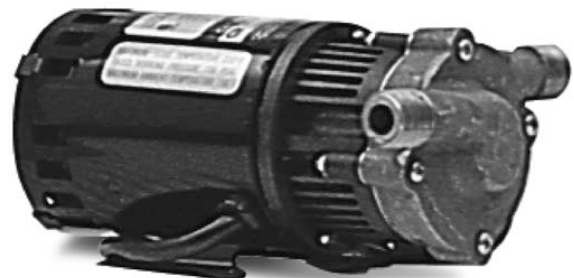

SPECIFICATIONS

Catalog No.	Model No.	Flow @ 1 Ft. (GPM)	Max. Head (Ft.)	Max. PSI	Inlet/ Outlet (MNPT)	Imp. Dia.	Motor Data						Wt. Total (Lbs.)	
							Volts	Hertz	RPM	Phase	HP	Watts		Amps
579000	CMD-100-3B	3	4.0	1.73	1/2"	2.00"	115	60	1550	1	1/125	35	.43	4.8
579200	CMD-100-5B	6.2	12.0	5.2	1/2"	1.69"	115	60	3000	1	1/25	81	.60	6.5

OVERALL DIMENSIONS

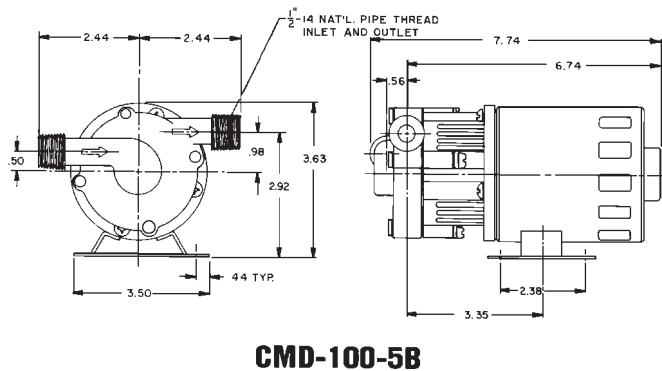
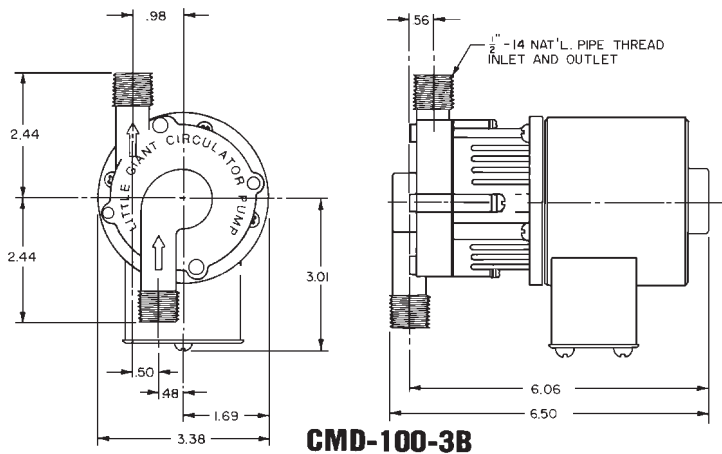

For Replacement Parts, contact:
 Grainger Parts
 1657 Shermer Road
 North Brook, IL 60062-5362

Phone: 800.323.0620
 Fax: 847.498.3402

PUMP PERFORMANCE CURVE*
 CMD-100 SERIES
 115 VOLTS, AC 60 HZ.

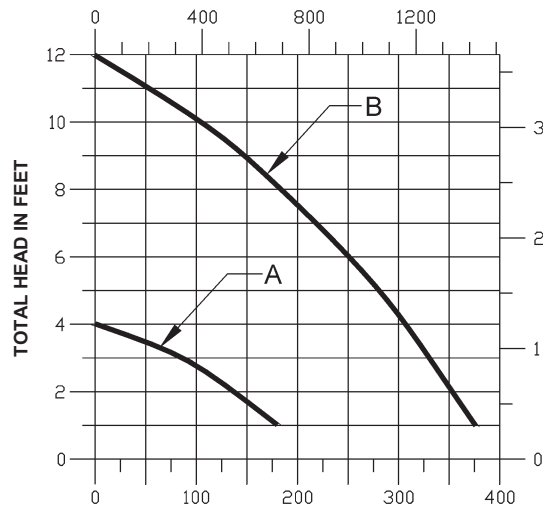

CAPACITY IN U.S. GALLONS PER MINUTE

A = CMD-100-3B
 B = CMD-100-5B
 *Pumping Room Temperature (23° C) water

LIMITED WARRANTY

Your Little Giant product is guaranteed to be in perfect condition when it leaves our Factory. It is warranted against defective materials and workmanship for a period of 12 months (90 day warranty on Models: 1-AA-OM, GKPK-SC, PP-1, PPS-1, PP-12, PPS-12, PP-230 and Cooler King) from date of purchase by the user. No warranty on brush wear in Model 35-OM and impeller or cam in Models PP-1, PP-12, and PP-230. Any product that should fail for either of the above two reasons and is still within the warranty period will be repaired or replaced if returned prepaid to our Factory. All defective products returned under warranty will be fully inspected to determine "CAUSE OF FAILURE" before any warranty is approved. Little Giant will honor the warranty within the warranty time period specified on satisfactory written proof of purchase.

DISCLAIMER: Any oral statements about the product made by the seller, the manufacturer, the representatives or any other parties, do not constitute warranties, shall not be relied upon by the user, and are not part of the contract for sale. Seller's and manufacturer's only obligation, and buyer's only remedy, shall be the replacement and/or repair by the manufacturer of the product as described above. Neither seller nor the manufacturer shall be liable for any injury, loss or damage, direct, incidental or consequential (including, but not limited to, incidental or consequential damages for lost profits, lost sales, injury to person or property, or any other incidental or consequential loss), arising out of the use or the inability to use the product, and the user agrees that no other remedy shall be available to it. Before using, the user shall determine the suitability of the product for his intended use, and user assumes all risk of liability whatsoever in connection therewith. **The warranty and remedy described in this limited warranty is an EXCLUSIVE warranty and remedy and is IN LIEU OF any other warranty or remedy, expressed or implied, which other warranties and remedies are hereby expressly EXCLUDED,** including but not limited to any implied warranty of **MERCHANTABILITY OR FITNESS FOR A PARTICULAR PURPOSE.** Some states do not allow the exclusive or limitation of incidental or consequential damages, so the above limitation or exclusion may not apply to you. This warranty gives you specific legal rights, and you may also have other rights which vary from state to state.

Warranty will be VOID if any of the following conditions are found:

1. Sealed motor housing opened.
2. Product connected to voltage other than indicated on name plate.
3. Cord cut off to a length less than three feet.
4. Pump allowed to operate dry (fluid supply cut off).
5. Pump used to circulate anything other than fresh water, light oils, or other mild liquids at approximately room temperature.
6. Product abuse by customer.

The National Electric Code requires a Ground Fault Circuit Interrupter (GFCI) be installed in the branch circuit supplying fountain equipment rated above 15 volts. Part number 599335, GCI-1, is in stock and we recommend each pump be used with a GCI.

LITTLE GIANT WARRANTY STATEMENT

LIMITED WARRANTY

KEEP THIS FOLDER

File this for safe keeping. It may be valuable to you for service under the term of the warranty.

Date of Purchase _____

Name of Dealer _____



Little Giant Pump Company
 P.O. Box 12010

Oklahoma City, OK 73157-2010
 (405) 947-2511 • Fax: (405) 947-8720

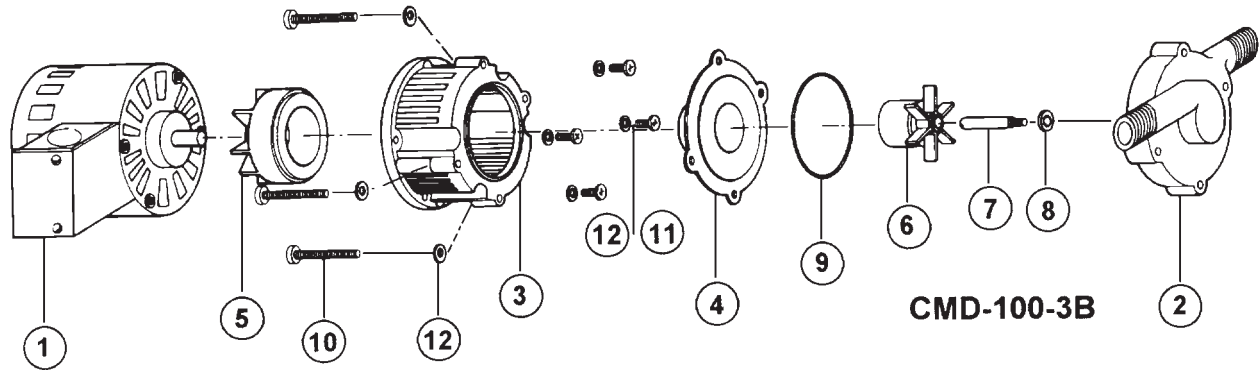

CMD-100-3B

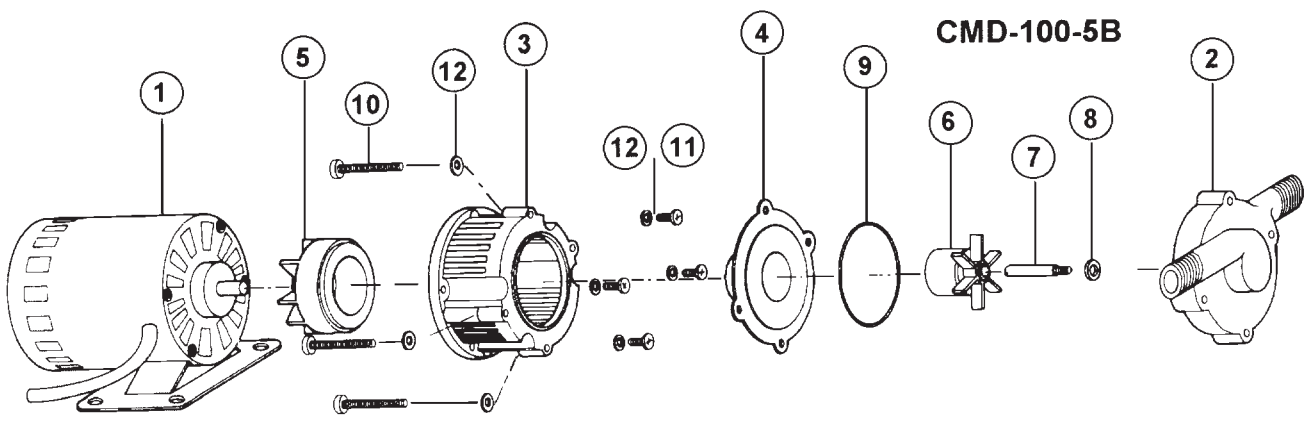

CMD-100-5B

PARTS LIST			MODEL & CATALOG NO.	
ITEM NO.	PART NO.	DESCRIPTION	CMD-100-3B	CMD-100-5B
1	977441	MOTOR, 115V	●	
1	977448	MOTOR, 115V		●
2	179002	VOLUTE, BRASS	●	●
3	179030	HOUSING	●	●
4	179010	BACKPLATE	●	●
5	179040	DRIVE MAG. ASS'Y	●	●
6	179021	IMPELLER ASS'Y	●	
6	179028	IMPELLER ASS'Y		●
7	179023	SHAFT, IMPELLER	●	●
8	921094	BEARING, THRUST	●	●
9	924031	O-RING	●	●
10	901430	SCREW, 8-32 X 1 1/4" LG	4	4
11	901424	SCREW, 8-32 X 1/2" LG	3	3
12	921059	WASHER, LOCK #8	7	7

LITTLE GIANT PUMP COMPANY

Telephone (405) 947-2511 • 3810 N. Tulsa St. • Oklahoma City, OK 73112