

Little GIANT[®]

Pump Company

CMD-100-3B SERIES



Features

- Bronze pump head
- Magnetic drive design
- Rated for up to 212 deg. F. water
- Withstands 150 PSIG line pressure
- Oversized sleeve bearings for long life
- Dual-fan cooled 1550 RPM motor
- Ryton[®] impeller
- Stainless steel separator plate
- Silicon O-ring
- Impedance protected

Construction

- Motor — 1/40 HP
- Intermittent Liquid Temp. up to — 212° F
- Intake — 1/2" MNPT
- Discharge — 1/2" MNPT
- Housing — N/A
- Cover — N/A
- Volute — Bronze
- Impeller — Nylon/Ryton[®]
- Shaft Seal — N/A

Little Giant Circulator Pumps have been specifically developed for applications in solar heating, heat exchange units and open or closed commercial and domestic hot water recirculating systems. The pump features dual fan cooling for increased motor life, balanced drive magnet which prevents premature motor wear and oversized bearing oilers for extended bearing life. The non-self priming, inline use circulator units are capable of pumping liquids at temperatures up to 212 degrees F., 100 degrees C., and withstanding line pressures up to 150 PSIG. The circulator pump motor can be easily removed without removing entire unit after installation. Ryton[®] impeller, bronze volute, stainless steel shaft and magnet separator and silicon O-ring.

Little Giant Pump Co.

CMD-100-3B SERIES

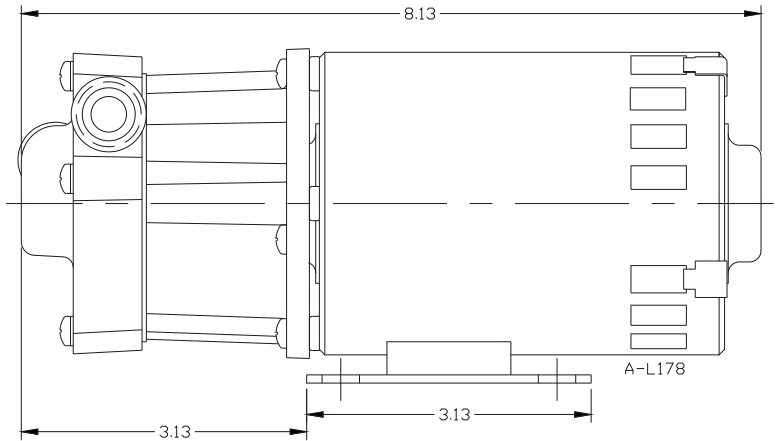
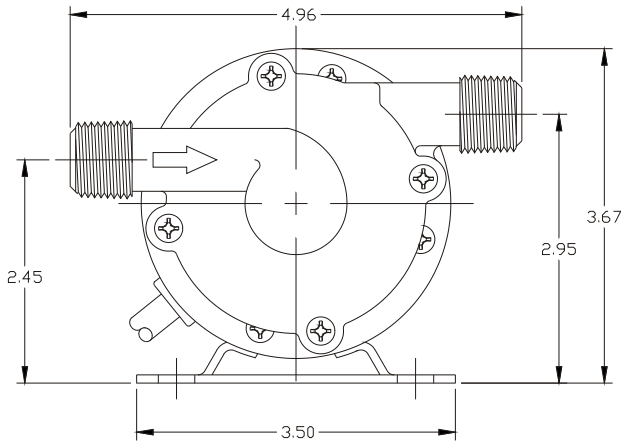

Specifications

Model No.	Item No.	Discharge	Intake	Listings	HP	Volts	Hertz	Amps	Watts	Performance (GPH @ Head)		Shut Off Feet	PSI	Pwr. Cord (ft)	Weight (Lbs.)
										1'	3'				
CMD-100-3B	579000	1/2" MNPT	1/2" MNPT	UR/C-CSA	1/125	115	60	0.4	34	180	85	4	1.7	1.25	5.00

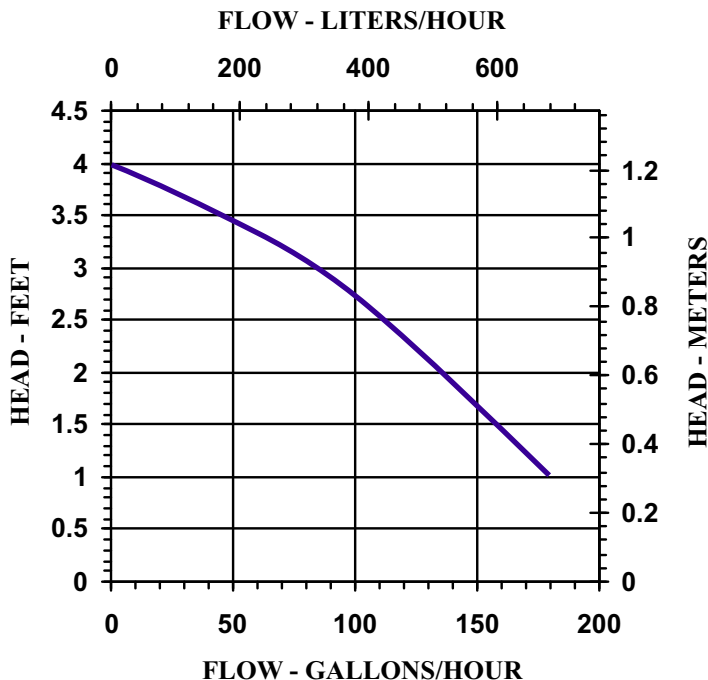

Replacement Parts

Volute	179002
Backplate	179010
Impeller	179021
Thrust Washer	921094
Impeller Shaft	179023
O-ring	924031
Magnet Housing	179030
Drive Magnet	179040

Little Giant Pump Co.
 PO Box 12010 Phone: 405.947.2511
 Okla. City, OK 73157 Fax: 405.228.1550
www.LittleGiantPump.com