



Engineered for life



AC Canned Spherical Motor Centrifugal Pumps

Applications

Specifically designed for the following use:

- Recirc Pump for Tankless Water Heaters

Specifications

Pump:

- Max Capacities: 3.8 GPM
- Max Head: 24.5'
- Pipe Connections:
1/2" NPT connection to the angle stops
- Maximum Working Pressure: 150 PSI
- Maximum Temperature: 230° F
- Rotation: counter clockwise when viewed from the motor end

Motor:

- AC Magnetically Driven Spherical Motor
- 115 Volt 98 Watts 60 Hz, 3450 RPM
- 230 Volt 98 Watts 50 Hz, 2850 RPM
- Automatic Overload Protection

Features

Compact Design:

Close coupled, space saving design provides easy installation.

Mounting:

Pump can be mounted horizontally or vertically with motor end down.

Motor Bracket:

Powder coated with SS fixture for easy installation.

Construction:

Lead free brass construction "nickle" plated.

Ceramic Bearing Ball and Carbon Bearing Cap:

High density ceramic bearing ball and graphite impeller bearing cap designed for high efficiency and long life.

Impeller:

Highly efficient and dynamically balanced with carbon bearing for smooth ultra quiet operation.

Casing:

Casing is lead free brass construction.

Mechanical Seal:

Unique patented design has no mechanical seal which is a potential leak path.

Motor:

Patented spherical motor pump design is ultra quiet and is designed for continuous operation. All ratings are within working limits of the motor.

Noise level:

Whisper quiet, less than 30 db

Weight:

Lightweight construction weighs less than 6lbs.

Materials of Construction (Wetted Parts)

Part	Materials
Pump Housing	Lead Free Brass
"O" Ring	EPDM
Impeller	Nylon/PPO
Bearing	Carbon/Ceramic
All Other Wetted Parts	316 Stainless Steel or Plastic

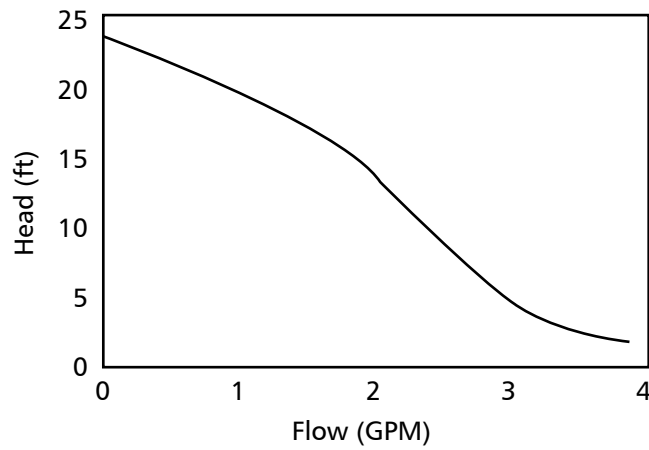
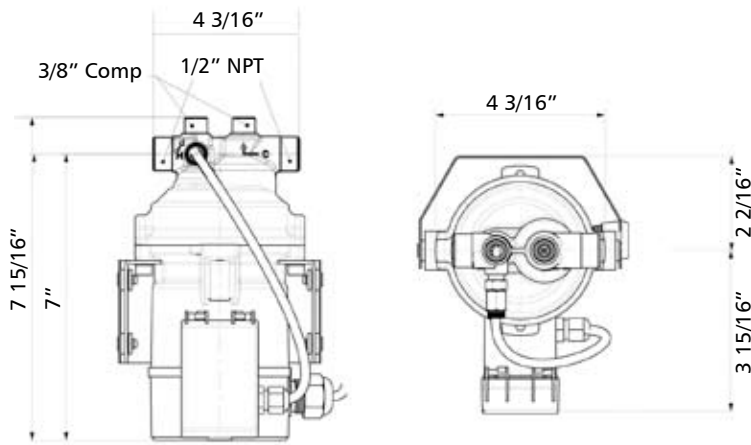

ITT
 3878 S. Willow, Suite 104
 Fresno, CA 93725
 Tel: (559) 265-4730 (800) 554-6853
 Fax: (559) 265-4740 (800) 453-7523
 www.lainginc.com



Engineered for life