PACO Packaged
Condensate Return Units

**Installation
Operating
&
Maintenance Instructions**

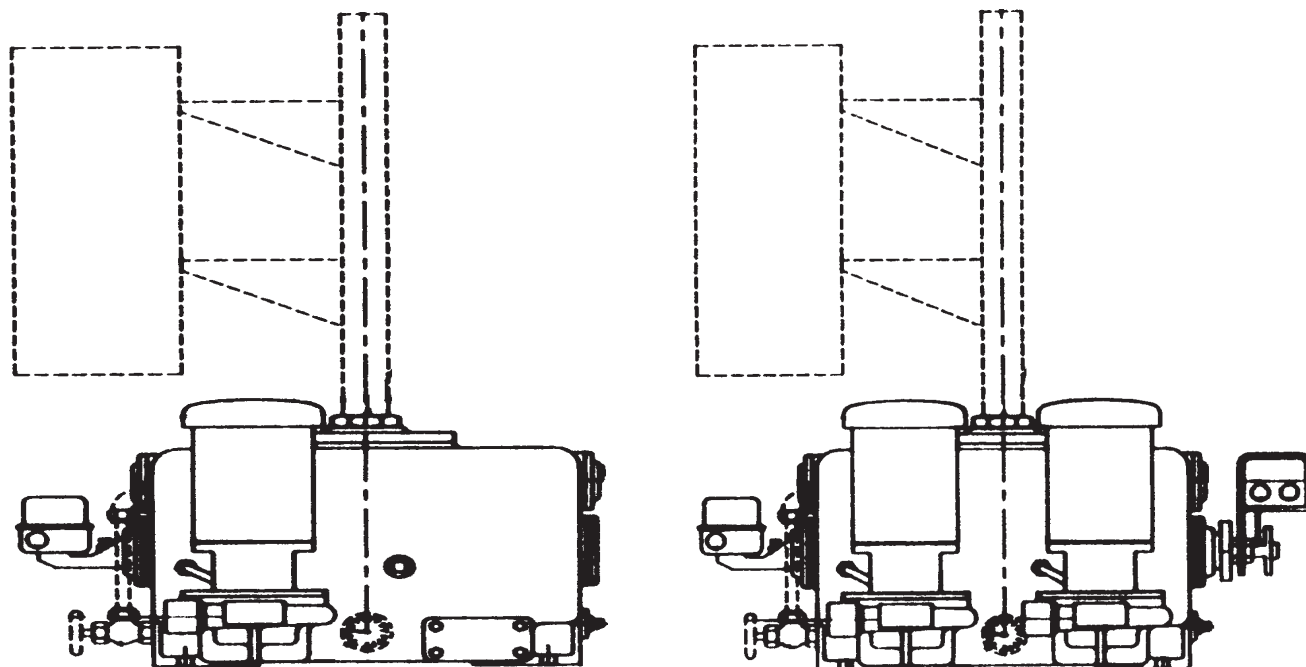

TABLE OF CONTENTS

I. INSTALLATION MECHANICAL

A. Pump Identification 3
B. Receiving 3
C. Temporary Storage 3
D. Location 3
E. Piping-General 3
F. Suction (Inlet) Piping 3

+3

G. Mechanical Seals 4
H. Anchoring 4

II. INSTALLATION-ELECTRICAL

A. Motors, General 5
B. Installation With Factory Mounted Motor Controls 5-6
C. Installation With Motor Controls Not Factory Mounted 6
D. Motor-Rotation 6
E. Adjustment of Pilot Devices 6
F. Pump Shutdown 6

III. OPERATION

A. Operating Sequence 6
B. Pre-Start Checklist 6
C. Starting 6-7
D. Voltage Regulation 7
E. Short Duration Shutdown 7
F. Extended Period Shutdown 7

IV. MAINTENANCE

A. Motor Lubrication 7
B. Mechanical Seals 8-9
C. Wear Rings 9-11
D. Disassembly 9-11

V. TROUBLESHOOTING 7

VI. WARRANTY 7

VII. SALES AND SERVICE CENTERS 7

I. INSTALLATION-MECHANICAL

Read these instructions thoroughly before installing and operating your PACO Type L Centrifugal Pump. Successful operation depends on careful attention to the procedures described in Sections 1, 2 and 3 of this manual. Keep this instruction manual handy for future use.

A. PUMP IDENTIFICATION

- All PACO pumps are identified by Catalog and Serial Numbers. These numbers are stamped on the pump nameplate (Fig.1a) affixed to each pump volute casing, and should be referred to in all correspondence with the Company.

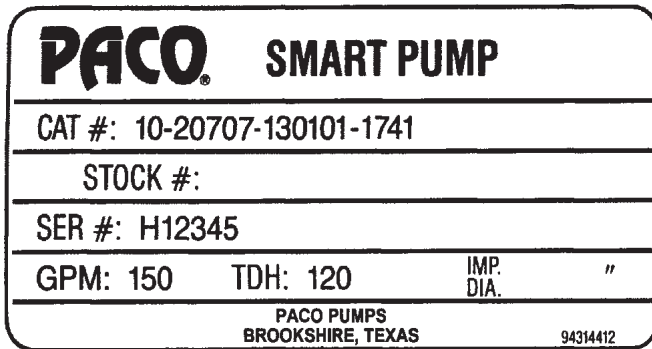

FIGURE 1a

B. RECEIVING

- Check pumping unit for shortage and damage immediately upon arrival. Pump accessories when required are packaged in a separate container and shipped with the unit.
- If equipment is damaged in transit, promptly report this to the carrier's agent. Make complete notations on the freight bill to speed satisfactory adjustment by the carrier.

C. TEMPORARY STORAGE

- If pump is not to be installed and operated soon after arrival, store it in a clean, dry area of moderate ambient temperature.
- Rotate the shaft by hand periodically to coat bearing with lubricant to retard oxidation and corrosion.
- Follow motor manufacturer's storage recommendations where applicable.

D. LOCATION

- The packaged Condensate Unit must be situated with sufficient accessibility for maintenance and inspection. If the unit is equipped with a mounted panel, there must be at least 30" of clear space in front of the panel extending down to the floor.
- Be sure the correct power source is available for the motor. Electrical characteristics should match those specified on the motor data plate.
- Avoid pump exposure to sub-zero temperatures to prevent pump liquid from freezing. If freezing conditions exist during shutdown periods, see Section 3E for specific recommendations.

E. PIPING-GENERAL

- Figure 2a shows a suggested piping arrangement for a duplex Condensate Unit.
- Use pipe hangers or other supports at adequate intervals to provide complete piping support near the pump. Piping should be independently supported and aligned so that no strain is transmitted to the pump case.
- Piping should be as straight as possible, avoiding unnecessary bends and fittings. Where necessary, use 45° or long-radius 90° pipe fittings to decrease friction loss.
- Short discharge piping can be the same diameter as pump discharge size. Longer piping should be one or two sizes larger depending on length.
- Pump discharge should be fitted with an isolation valve to facilitate pump removal and maintenance. PACO's optional discharge restriction valve will serve as an isolation valve.

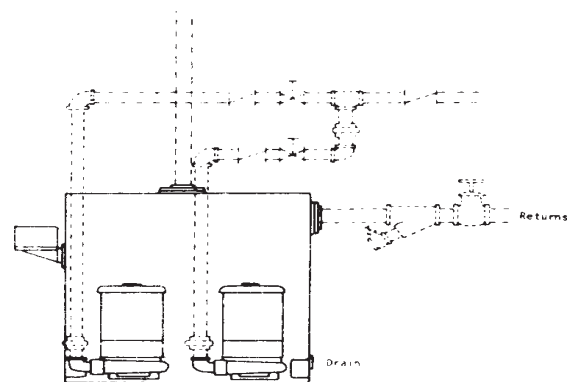

FIGURE 2a

F. MECHANICAL SEALS

All PACO Condensate Return pumps come equipped with mechanical seals are matched to conditions for which the pump was sold. Observe the following precautions to avoid seal damage and obtain maximum seal life:

- Do not exceed temperature or pressure limitations for the mechanical seal used.
- **Do not run the pump dry or against a closed valve!** Dry operation will cause seal failure within minutes.
- Clean and purge suction piping in new installations before installing and operating pump. Pipe scale, welding slag and other abrasives can cause rapid seal failure.

G. ANCHORING

All cast iron receivers are provided with corner slots for anchor bolts. Galvanized steel tanks have a threaded nut welded to the underside for anchoring with a single 1" bolt. The optional cast iron base for steel tanks provides three anchor bolt holes. Cast iron or steel tanks with integrally mounted panels must be bolted down.

II. INSTALLATION—ELECTRICAL

A. MOTORS-GENERAL

The motor control circuit must have the following components in order to comply with the National Electrical Code.

- **Motor Disconnecting Device:** A motor disconnecting device must be installed that is capable of disconnecting both the controller (motor starter) and the motor from their source of power.

The disconnecting device must be located so that the controller (motor starter) can be seen from the disconnecting means. In all cases the distance from the disconnecting device to the controller must be less than 50'.

In most installations the disconnecting device will be a circuit breaker or fusible disconnect switch.

- **Motor short circuit and ground fault protection:**

Short circuit and ground fault protection are usually provided by means of a circuit breaker or fusible disconnect switch.

The selection of the size of the circuit breaker or fuse must be in accordance with Section 430-52 and Table 430-152 of the National Electrical Code.

- Motor controller with running over current protection (magnetic starter):

These components must be installed in accordance with applicable local and state electrical codes in addition to the National Electrical Code.

B. INSTALLATION WITH FACTORY MOUNTED MOTOR CONTROLS

- Check incoming power source to insure it is the same as the voltage and phase of the motors and controls supplied.
- For factory mounted control panel—install conduit and wiring from circuit breaker to the control panel in accordance with applicable local and national codes.

NOTE: The National Electrical Code requires that wires be sized for a minimum of 225% of one motor's nameplate full load amps.) (See wiring diagram in Appendix I.)

- Factory mounted magnetic starters—install conduit and wiring from branch disconnect devices to the magnetic starters in accordance with applicable local and national codes. It is recommended that each motor have its own disconnect and motor branch circuit, ground fault and short circuit protection.

C. INSTALLATION WITH MOTOR CONTROLS NOT FACTORY MOUNTED

- Mount the control panel or motor starter(s) in close proximity to the condensate unit to provide convenient control and ease of installation.
- Wire panel or starter(s) to motor(s) and float switch pilot devices. Wire to each motor must be sized for at least 125% of the motor nameplate full load amps. AWG #16 Type THW stranded wire is recommended for wiring of pilot devices (float switches.) (See Typical wiring diagrams in Appendix I.)
- Check incoming power source to insure it is the same as the voltage and phase of the motors supplied.
- Verify that the starters are suitable to operate pump motors on voltage and phase that is available.

D. MOTOR ROTATION

- After the unit has been wired and checked to insure that all components in the system (disconnect device, magnetic starters, pilot devices and motors) are properly connected, check motor rotation as follows:
- For 3 phase units only—bump the motors to insure that rotation is correct as indicated by the arrow cast in the pump volute.

IMPORTANT: The pumps must not be operated while dry. Use extreme caution that motors are energized only momentarily to determine proper rotation.

- For single phase units—the motors used on most single phase units are not reversible and have been selected with the correct rotation.

E. ADJUSTMENT OF PILOT DEVICES

There are two types of pilot devices used in the GR Condensate Units: float switches and (optional mechanical alternators. These pilot devices may be one of two configurations, threaded mount or flanged mount.

1. Threaded Mount Float Switch and Optional Mechanical Alternator.
 - Prior to attempting any adjustment of the float switch, verify that the shipping strap (item C of Fig.3) that is mounted between the frame and the operating lever has been removed. The float is held in one position by this strap and will not start or stop the pump until it is removed.
 - Adjustment strip A of Fig. 3a is used to adjust the point at which the float switch or (optional) mechanical alternator starts a pump. Adjustment strip B is used to adjust the point at which the float switch or (optional) mechanical alternator stops the pump.
 - **CAUTION: Never run the pump dry hope that it will prime itself!** Serious damage to the mechanical seal will result.
2. Flanged Mount Float Switch and (optional) Mechanical Alternator
 - Adjustment of the pump start and stop points is achieved by adjusting nuts A and B in Fig. 4a. Nut A adjusts the stop point and Nut B adjusts the start point.

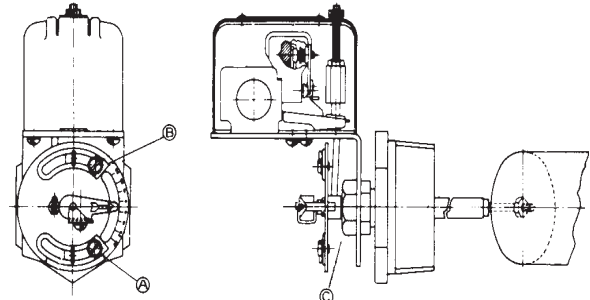

Figure 3a

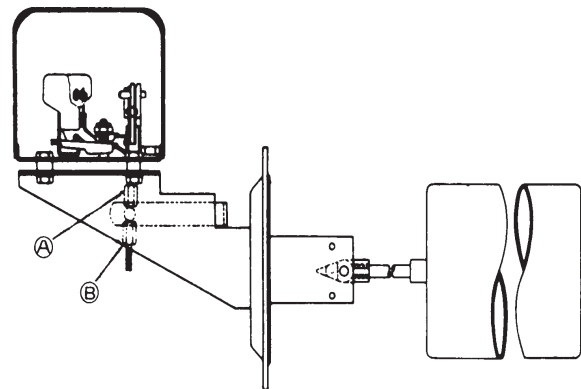

FIGURE 4a

3. Mechanical Alternator

- While the pump start and stop points of the mechanical alternator can be adjusted by using the procedures of II.E.1 or II.E.2, the starting point of the second pump with respect to the starting point of the first pump is not adjustable. Assume the starting point of the first pump is at 6" of water and the second pump starts at 8" of water. If the starting point of the first pump is adjusted to 8" by the method described above, the second pump will also be changed to approximately 10". The starting point of the second pump is not independently adjustable and must be considered when making adjustable to the first pump start point is adjusted, check the operation of the second pump to insure that the second pump start point is not so high that the float is restricted by the receiver or that the water level rises to a point that water backs up in the supply piping before starting the second pump.
- In some installations it is desirable to provide an auxiliary float switch to turn both pumps on when the liquid level reaches a point above the starting point of the second pump. This serves as a backup in the unlikely event that the mechanical alternator should fail. The auxiliary float switch should be adjusted as described in paragraphs II.E.1. or II.E.2. to turn the pumps on at a level above the second pump start and to stop the pumps at the same level that the mechanical alternator stops the pumps.

- If both pumps operate each time the water level rises, check the adjustment of the auxiliary float switch and the mechanical alternator.

F. SHUTDOWN

When wiring has been completed, turn disconnect(s) to the “off” position and tag with “Do Not Operate” sign until such time as the complete system is ready for start-up and the tank has water in it.

III. OPERATION

A. OPERATING SEQUENCE

1. Pump Sequence—Simplex

The simplex condensate unit uses a single pump with one float switch. The float switch has an adjustable on-off water level differential. The simplex sequencing is as follows:

- When the water level in the tank rises to the “pump on” position, the float switch contacts close and start the pump.
 - Water is pumped from the tank at a rate equal to or exceeding that of the incoming stream.
 - When the water lowers to the “pump off” level, the float switch opens and stops the pump.
- #### 2. Pump Sequence—Duplex with 2 float switches. The standard duplex unit includes two identical pumps and two float switches. The sequence is as follows:
- When the water level in the tank rises to the “lead pump on” position, the first float switch closes and starts the lead pump.
 - If the lead pump capacity is sufficient to handle the incoming flow, the level will go down to the “pump off” position and the float switch will stop the pump (the normal operation.)

- If the lead pump capacity is not sufficient to maintain the desired water level, the rising liquid will trip the second float switch, energizing the lag pump.
- The combined capacities of both pumps should bring the water level back down to the “pumps off” position. Where both switches will open simultaneously to stop the pumps.

NOTE: For units supplied with a PACO electrical control panel an electric alternator switches lead pump and lag pump for each cycle of the first float switch.

- #### 3. Pump Sequence—Duplex with Mechanical Alternator and One Float Switch—A mechanical alternator is available as an optional replacement for one of the standard float switches. This alternator sequences the pumps exactly as described above. The float switch can be used as a back-up means of starting both pumps should the alternator fail.

B. STARTING

- Check voltage, phase, and frequency of line current against motor data plate.
- Make sure all wiring connections to the motors and starting devices match the wiring diagram.
- If motor has been in storage for an extended period of time, either before or after installation, refer to motor instructions before starting.
- Close discharge gate valve.
- Fill tank with water up to the level of the “pumps off” switch position. (Pumps must never be started without water in tank.)
- Check pump rotation (See Section II, Paragraph D.) Rotation should be as indicated by arrow on pump volute. Rotation is changed by interchanging any two of the three motor leads on three phase motors.
- With motors wired for correct rotation, turn pumps on “automatic” and allow tank to fill the “pump on” level.
- When the pump comes on, slowly open the discharge gate valve allowing water to gradually fill the piping. Permitting water to rapidly enter an empty system can result in severe water hammer.

C. VOLTAGE REGULATION

The motor will operate satisfactorily under the following conditions for voltage and frequency variation, but not necessarily in accordance with the standards established for operation under rated conditions:

- The voltage variation may not exceed 10% above or below rating specified on the motor data plate.
- The frequency variation may not exceed 5% above or below motor rating.
- The sum of the voltage and frequency variations may not exceed 10% above or below motor rating, provided the frequency variation does not exceed 5%.

D. DISCHARGE RESTRICTION VALVE

In many condensate return systems, problems do not stem so much from under-capacity of the pumps, but over-capacity. This occurs when system piping losses are lower than anticipated and the pump runs at a capacity above that desired. The symptoms of this problem are short-cycling and possible cavitation noise of the lead pump. PACO offers an optional discharge restriction valve as a solution to this common difficulty.

E. SHORT DURATION SHUTDOWN

- For overnight or temporary shutdown periods under nonfreezing conditions, pump may remain filled with liquid. Make sure pump is fully primed before restarting.
- For short or frequent shutdown periods under freezing conditions, keep fluid moving within pump casing and insulate or heat pump exterior to prevent freezing.

F. EXTENDED PERIOD SHUTDOWN

- For long shutdown periods, or to isolate pump for maintenance, close suction gate valve. If no suction valve is used and pump has positive suction head, drain all liquid from suction line to terminate liquid flow into pump suction nozzle. Remove plugs in pump drain and vent taps, as required, and drain all liquid from pump volute casing.
- If freezing conditions will exist during long shutdown periods, completely drain pump and blow out all liquid passages and pockets with compressed air.

Freezing of pump liquid can also be prevented by filling pump with antifreeze solution.

IV. MAINTENANCE

A. MOTOR LUBRICATION

- To lubricate motor while running or at rest, remove grease drain plug (if any) and filler plug on grease fitting. Grease with clean lubricant until grease appears at drain hole or along motor shaft.
- Most fractional and some integral frame motors have “sealed-for-life” bearings, and do not require further lubrication throughout motor life.
- Always follow motor manufacturer’s lubricating instructions, and periodically check grease fittings and drain plugs for leaks.
- If lubricating instructions do not accompany motor, refer to **Table 5a** for recommended lubrication periods.

MOTOR RPM	MOTOR HP	OPERATING CONDITIONS		
		STANDARD	SEVERE	EXTREME
1780 & BELOW	10-40	1-3 YRS.	6 MOS.-1 YR.	6 MOS.-1YR
	50-150	1 YR.	3 MOS.	6 MOS.
	200 & UP	1 YR.	3 MOS.	6 MOS.
ABOVE 1750	(ALL HP)	6 MOS.	3 MOS.	3 MOS.

STANDARD CONDITIONS:
8 hours per day operation, normal or light loading, clean air, 100°F, maximum ambient temperature.

SEVERE CONDITIONS:
Continuous 24-hour operation, shock loading or vibration, poor ventilation, 100° - 150°F, ambient temperature.

EXTREME CONDITIONS:
Continuous operation, heavy shock or vibration, dirt or dust in the air, extreme ambient temperatures.

TABLE 5a

- Grease should have a melting point at least 100° F higher than the temperature to which it is subjected, and should be N.L.G.I. Grade No.2. See Table 6a for typical approved ball bearing lubricants.

MANUFACTURER	LUBRICANT
SHELL	DOLIUM R
EXXON	POLYREX
CHEVRON	SRI GREASE NLGI 2
	BLACK PEARL - NLGI 2
PHILIPS	POLYTAC
TEXACO	POLYSTAR RB

TABLE 6a

B. MECHANICAL SEALS

Mechanical seals are precision made parts. When properly installed, they prevent pump liquid from leaking out around the shaft. Seal faces can be easily scratched or damaged by handling, and extreme care must be taken to prevent their contact with hard surfaces or abrasives.

- Figure 7a (below) identifies major seal components, and illustrates how an **end face mechanical seal** functions when properly installed inside pump casing.
- If seal failure develops, follow the procedures described in Section D and replace worn seals with new mechanical seals.

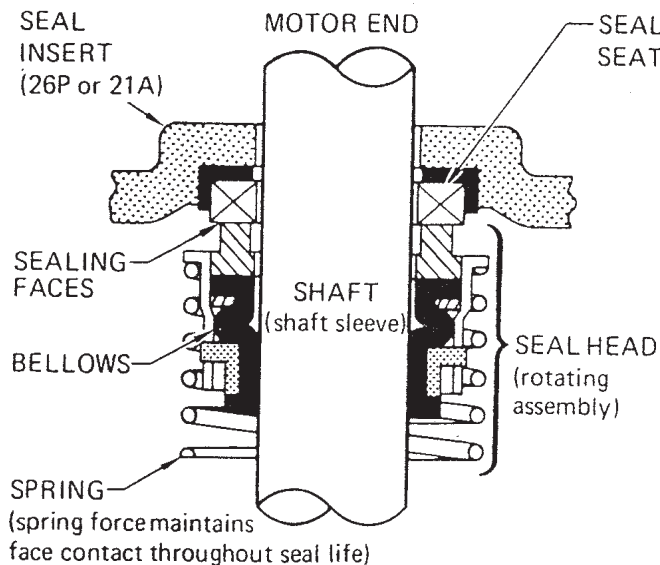

FIGURE 7a - End Face Mechanical Seal

C. WEAR RINGS

- Case wear rings are designed to serve as a buffer between pump casing and rotating impeller. As the name implies, these rings will wear with pump use and must be periodically replaced. Water ring life varies significantly with composition of liquid being pumped, and will be greatly extended by absence of abrasive particles in liquid.
- Wear rings also serve an important hydraulic function, minimizing pressure leakage from high to low pressure zones inside the pump volute casing. Rings should be replaced when the diametrical clearance between impeller and wear ring exceeds .030 in.

- To replace wear rings, follow procedures outlined in Section IV D. Always make sure wear ring cavity in pump volute casing is thoroughly cleaned **before** replacement, to insure a properly aligned fit.

D. DISASSEMBLY

1. Close valve on tank inlet and drain water from tank. If remaining pump on duplex system is to be operated alone while one pump is being serviced, blank off plate 02007063C must be used on tank flange where pump to be serviced was removed. If system can be left inoperative while pump is being repaired, the empty volute may be left bolted to tank.
2. Disconnect Seal vent line.
3. Remove volute cap screws and lift motor from volute (1a). (See fig. 7 and Fig. 8).
4. The range of condensate pump selections includes two general motor types: fractional frame and integral frame. Fractional frame motors have a right-hand threaded shaft for a threaded impeller, while the integral frame motors use a 7/8" diameter straight shaft with a key-way. Impeller removal is as follows:
 - a. Fractional Frame - Remove canopy and shaft end plug from motor to expose slotted end of shaft. Heat impeller hub to 400°F to loosen Loctite compound on threads. Holding the shaft with a large screw driver in the slotted end, unscrew the hot impeller by inserting a suitable lever between two vanes and turning counterclockwise.
 - b. Integral Frame - Remove socket head screw and stainless steel washer from impeller eye. Loosen the press fit by warming impeller hub and pry impeller off the shaft with a pair of levers. Remove impeller key.
5. Remove spring and rotating seal elements from shaft. To break bond between the rubber bellows and shaft, lightly lubricate shaft and pry seal head with two bars.
6. The seal seat will be housed in either a motor bracket for fractional frame motors; or a backplate for integral frame motors. Remove this seal housing piece and drive the seal seat out from the back of the housing.
7. The water slinger may be removed at this point.
8. Integral frame motors use a bronze sleeve under the seal to protect the steel shaft from the pumpage (fractional motors have stainless steel shafts). Should this sleeve require replacement, it can be removed by heating to 400° F to loosen the Loctite compound.
9. The suction wear ring, if installed, is removed using a suitable puller, or by splitting the ring with a chisel.

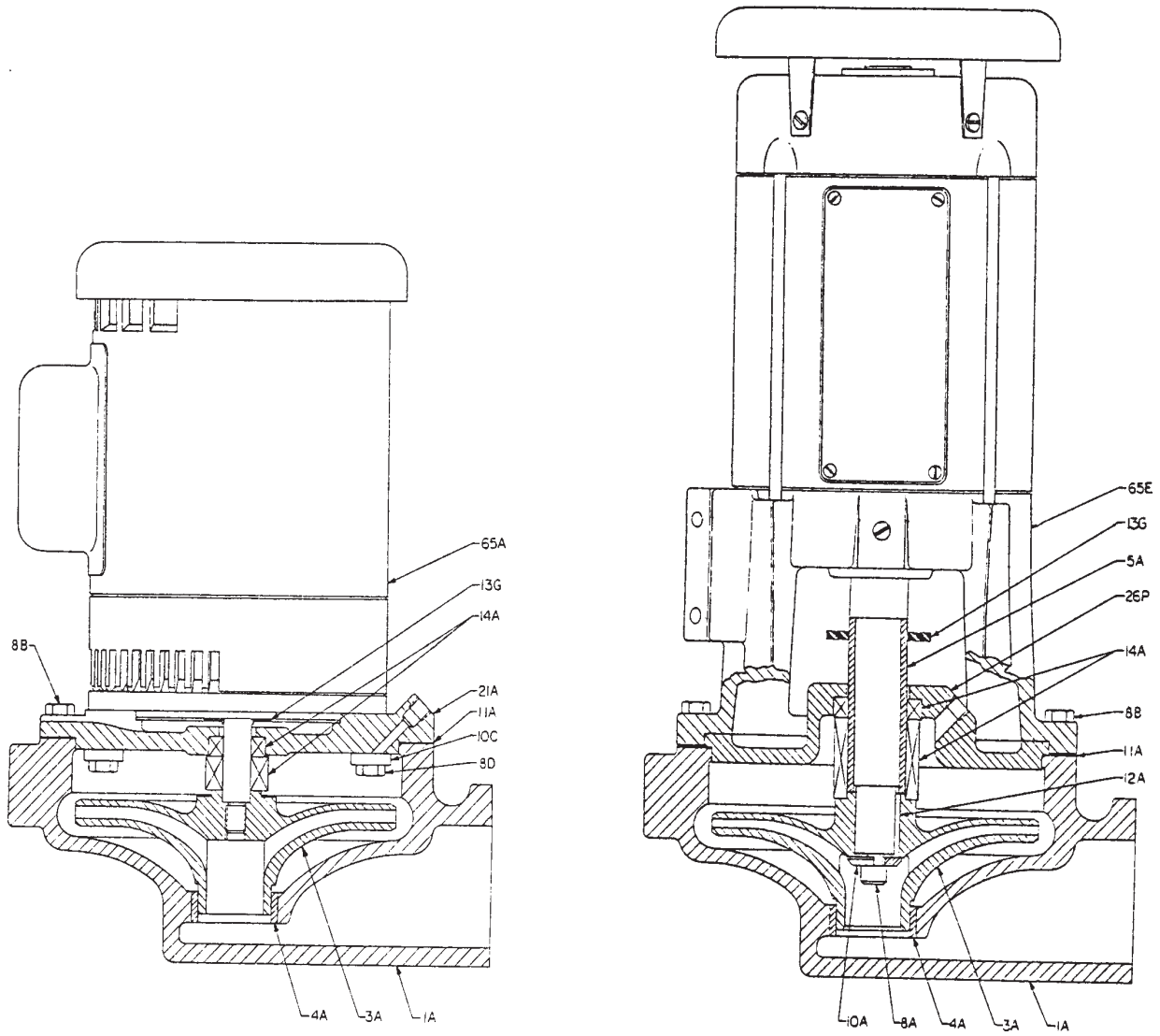
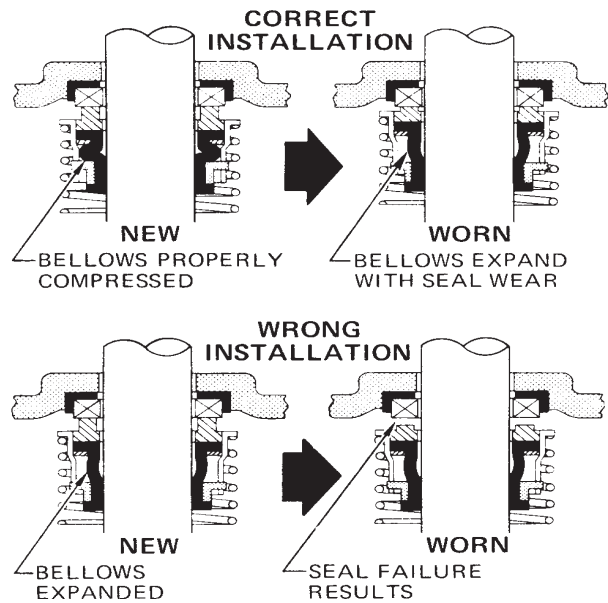

FIGURE 8

E. Assembly

The assembly procedure is basically the reverse sequence of the disassembly, with special attention given to the mechanical seal.

1. For pumps with wear rings, press new suction wear ring into volute using an arbor press or a block and mallet.
2. For pumps with sleeves, clean otor shaft and new sleeve with lacquer thinner or acetone and install sleeve on shaft using Type 601 Locite compound under sleeve. Rotate sleeve to distribute Locite and allow five minutes for hardening.
3. Press new seal seat properly into cavity of seal housing. Light oil should be applied to ease installation. Avoid direct contact of seal face with metallic objects, as any scratches will result in a leaking seal. Wipe seal face clean after installation.
4. Replace the water slinger.
5. Install seal housing over motor shaft. If one piece bracket is used, position so vent line will reach fitting on tank when motor is placed on position.
6. Clean and tightly oil the shaft or shaft sleeve making sure no sharp edges exist to cut the new seal bellows. Place seal head assembly (with out spring) onto shaft and push against seal seat until bellows is properly compressed. Press only on back portion of bellows, making sure notches on sealing washer line up with lugs on retaining ring. Once in place, the seal bellows bonds to the shaft making a liquid-tite seal. Do not disturb the seal after this bond has set.
7. Place the spring in position over the seal head.
8. On 9- 1/2" pumps, replace backplate using new gasket. Position insert housing so seal vent line will reach fitting on condensate tank when motor in proper position on volute.
9. On integral frame motor, replace impeller key and press impeller on shaft. Impeller is easier to install if the hub is heated to enlarge the bore slightly. Replace washer and cap screw.
10. On fractional frame motors, apply Locite compound Type 601 to threads and install impeller.



11. Using a new volute gasket, install the motor assembly on the volute and secure with volute cap screws. Check for free impeller rotation before replacing motor end cap and canopy. If any rubbing is detected, check for cocking of backplate, seal housing or volute fits.
12. Reconnect seal vent and replace tank drain plug.

F. TROUBLE SHOOTING CHECKLIST

1. Pump Does Not Deliver Any Liquid
 - a. Make sure liquid level in tank is above pump suction.
 - b. Low RPM - Make sure power is directly across-the-line, and motor is receiving full voltage. If frequency is too low, or if motor has an open phase, refer to motor manufacturer and make necessary correction. If power is supplied from separate generator source, make sure generator is running at full speed.
 - c. Incorrect Rotation - Make sure that pump (motor) is rotating in the proper direction. Check rotation arrow on pump volute casing.
 - d. Discharge head too high.
 - (1) Check discharge piping for friction losses. Make sure discharge head matches condition for which pump may correct conditions of excessively high discharge head. Make sure that no obstructions exist in discharge piping.
 - e. Impeller Clogged - Completely clean impeller passageways. Refer to Disassembly Instructions.
2. Pump Does Not Deliver Enough Liquid
 - a. Suction leaks air - make sure suction flange connections airtight. Make sure all leaks are completely sealed.
 - b. Impeller Damaged - Inspect pump impeller. If impeller is excessively worn, replace with new impeller.
 - c. Valves Too Small - Make sure area through ports of valves is at least as large as pump piping diameter and all valves are fully open during pump operation.
 - d. Low RPM - See Section "1" above.
 - e. Improper Pumping Conditions - See Section "1" above and "7" below.
 - f. Impeller Clogged - See Section "1" above.
3. Pump Does not Produce Enough Pressure
 - a. Speed too low. (See 1b above).
 - b. Excessive flow rate: Flow rate higher than anticipated - close discharge valve to raise pressure between pump and valve.
 - c. Pump cavitation present. Close discharge valve to decrease flow or raise "pump off" liquid level to increase NPSHA.
 - d. Impeller damaged. (See 2b above).
 - e. Wear ring excessively worn. Replace wear ring - see assembly - disassembly instructions.
4. Intermittent Pump Operation
 - a. Low Water Level - (See 1a above).
 - b. Suction Leaks Air - (See 2a above).
5. Pump Uses Too Much Power
 - a. Excessive Flow Rate - Partially close discharge valve.
 - b. Viscosity of Specific Gravity of Liquid Too High - Use motor with greater horsepower rating, reduced RPM, or reduced impeller diameter.
 - c. Incorrect Rotation - Make sure that pump (motor) is rotating in the proper direction. Check rotation arrow on pump volute casing.
6. Excessive Vibration
 - a. Noise from Bearings - Check lubrication, replace worn bearings.
 - b. Excessive Flow through Pump - Partial close discharge valve.
 - c. Inadequate NPSH - See Section 7.
7. Excessive Noise

A pump requires a minimum suction pressure or "head" to operate properly. The accepted term for this is "net positive suction head", NPSH. The NPSH (NPSH Available) must be equal or exceed the NPSHR (NPSH Required) or cavitation will occur. Cavitation may cause noise, vibration, low pump discharge pressure, or low pump capacity. In time it will physically damage the pump impeller. The noise produced is peculiar to cavitation - it

TROUBLESHOOTING CHECKLIST - continued

sounds as though the liquid pumped has marbles or pebbles in it which bounce against the pump walls as they pass through the unit. The long term damage to the impeller looks like erosion of the vanes and/or interior walls at the impeller inlet. The two most frequent causes of condensate unit cavitation are : (1) receiver water temperature too high (over 200 F),. and (2) excessive flow through the pump. **The NPSHR for a pump increases with flow. Excessive flow occurs if the pump is over-sized for the system conditions. When this happens, partially closing the discharge valve to reduce flow will stop cavitation.**

G. FACTORY AUTHORIZED PARTS

PACO maintains a stock of replacement parts at each of its manufacturing facilities. Shipment of these parts is normally made within three days after receipt of an order. In emergency situations, shipments can usually be made within 24 hours.

To order factory authorized parts, contact your local PACO representative. Use Parts List E1d.2 to select parts required for any unit using catalog number found on nameplate.

Be sure to include unit serial number and catalog number when ordering any parts.

RECOMMENDED PARTS

Although the pump included as a part of the PACO Condensate Unit normally requires very little maintenance, it is suggested that spare wearing parts be carried on hand. The recommended parts are:

Mechanical Seal
Wear Ring (where applicable)

**DUPLEX CONDENSATE CONTROL PANEL
WITH INDIVIDUAL FLOAT SWITCHES**

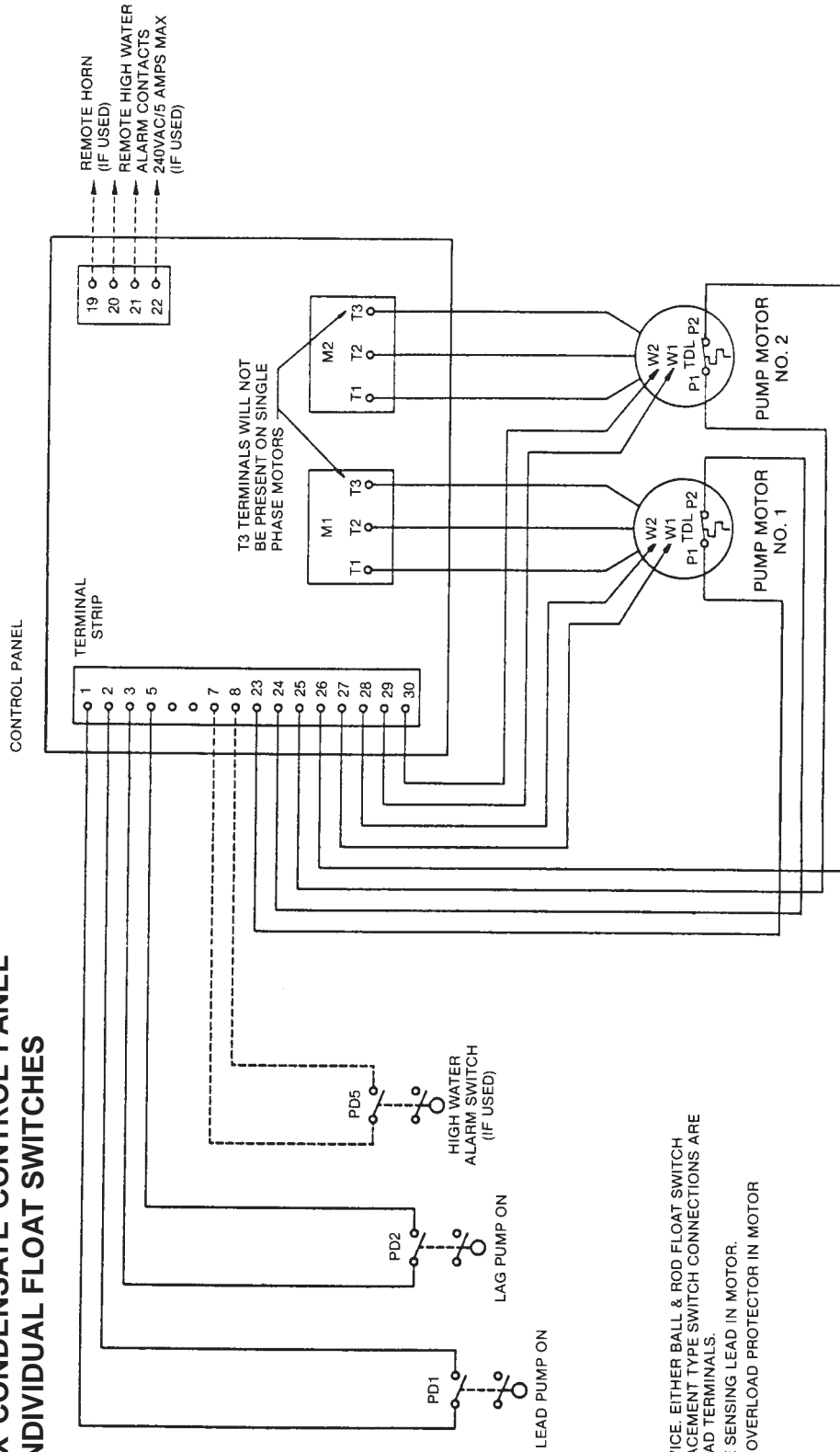

LEGEND:

PD PILOT DEVICE, EITHER BALL & ROD FLOAT SWITCH OR DISPLACEMENT TYPE SWITCH CONNECTIONS ARE LINE & LOAD TERMINALS.

W MOISTURE SENSING LEAD IN MOTOR.

TDL THERMAL OVERLOAD PROTECTOR IN MOTOR (IF USED)

- NOTES:**
1. TERMINALS 27, 28, 29, 30 WILL BE PRESENT ONLY ON PANELS THAT HAVE A SUBMERSIBLE MOTOR MOISTURE SENSING ALARM. MOISTURE SENSING LEADS SHALL BE THERMOPLASTIC TYPE TW INSULATED WIRE INSTALLED IN A SEPARATE DRY METALLIC CONDUIT NOT TO EXCEED 150 FEET.
 2. TERMINALS 7, 8, 19, 20, 21 & 22 WILL BE PRESENT ONLY ON PANELS THAT HAVE A HIGH WATER ALARM.
 3. JUMPER WIRES 23-24 AND 25-26 ARE ON THE TERMINAL STRIPS OF ALL PANELS. IF THE MOTORS SUPPLIED HAVE INTERNAL THERMAL PROTECTORS, REMOVE THE JUMPERS AND CONNECT THE LEADS ACROSS THE TERMINALS 23-24 AND 25-26.

CD 20472

**DUPLEX CONDENSATE CONTROL
PANEL WITH MECHANICAL ALTERNATOR**

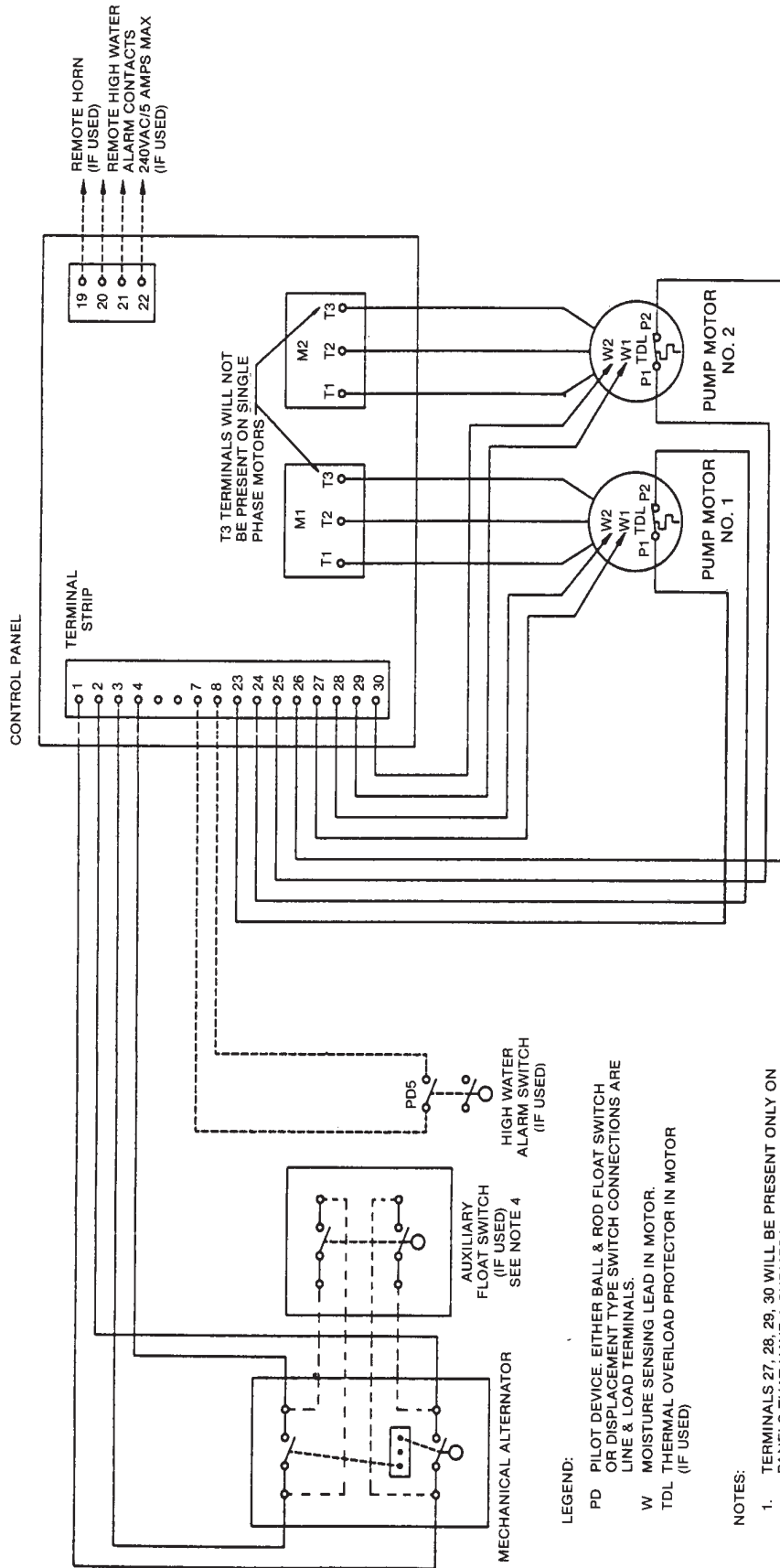

LEGEND:

- PD PILOT DEVICE, EITHER BALL & ROD FLOAT SWITCH OR DISPLACEMENT TYPE SWITCH CONNECTIONS ARE LINE & LOAD TERMINALS.
- W MOISTURE SENSING LEAD IN MOTOR.
- TDL THERMAL OVERLOAD PROTECTOR IN MOTOR (IF USED)

NOTES:

1. TERMINALS 27, 28, 29, 30 WILL BE PRESENT ONLY ON PANELS THAT HAVE A SUBMERSIBLE MOTOR MOISTURE SENSING ALARM. MOISTURE SENSING LEADS SHALL BE THERMOPLASTIC TYPE TW INSULATED WIRE INSTALLED IN A SEPARATE DRY METALLIC CONDUIT NOT TO EXCEED 150 FEET.
2. TERMINALS 7, 8, 21 & 22 WILL BE PRESENT ONLY ON PANELS THAT HAVE A HIGH WATER ALARM.
3. JUMPER WIRES 23, 24 AND 25, 26 ARE ON THE TERMINAL STRIPS OF ALL PANELS. IF THE MOTORS SUPPLIED HAVE INTERNAL THERMAL PROTECTORS, REMOVE THE JUMPERS AND CONNECT THE LEADS ACROSS THE TERMINALS 23-24 AND 25-26.
4. FLOAT SWITCH TO OPERATE BOTH PUMPS IN EVENT OF ALTERNATOR FAILURE. FLOAT SETTING IS TO BE HIGHER IN THE SUMP THAN THE SETTING OF THE MECHANICAL ALTERNATOR FLOAT.

CD 20473

**SIMPLEX CONDENSATE CONTROL PANEL
WITH A SINGLE FLOAT SWITCHES**

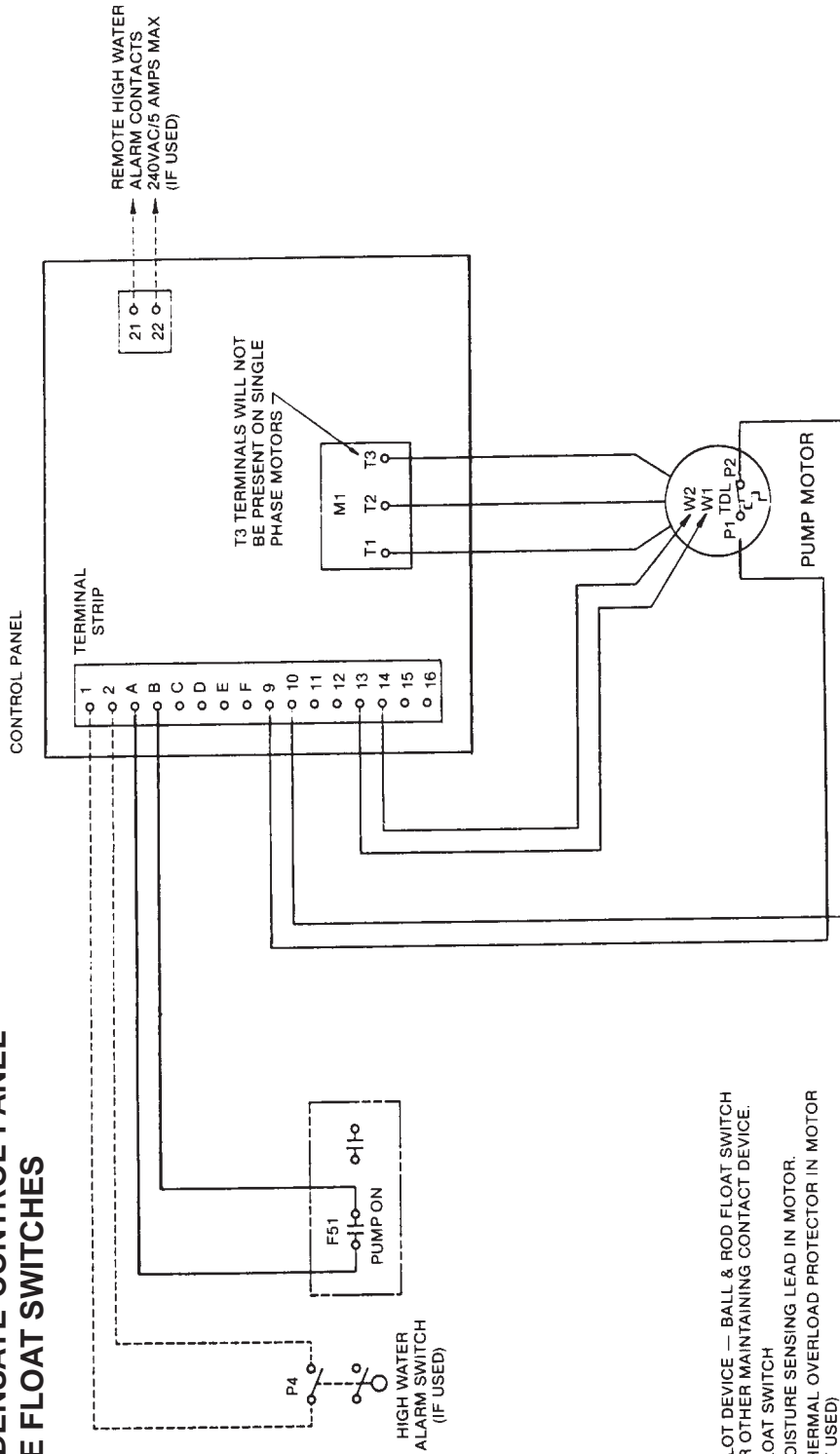

LEGEND:

- P PILOT DEVICE — BALL & ROD FLOAT SWITCH OR OTHER MAINTAINING CONTACT DEVICE.
- FS FLOAT SWITCH
- W MOISTURE SENSING LEAD IN MOTOR.
- TDL THERMAL OVERLOAD PROTECTOR IN MOTOR (IF USED)

NOTES:

1. TERMINALS 13 & 14 WILL BE PRESENT ONLY ON PANELS THAT HAVE A SUBMERSIBLE MOTOR MOISTURE SENSING ALARM.
2. TERMINALS 1, 2, 21 & 22 WILL BE PRESENT ONLY ON PANELS THAT HAVE A HIGH WATER ALARM.
3. TERMINALS 9 & 10 ARE PRESENT ON ALL PANELS BUT HAVE JUMPER WIRES CONNECTED ACROSS EACH PAIR. REMOVE THE JUMPERS IF MOTOR THERMAL OVERLOAD PROTECTORS ARE TO BE CONNECTED.

CD 20592

**SIMPLEX MAGNETIC STARTER
WITH INDIVIDUAL FLOAT SWITCH**

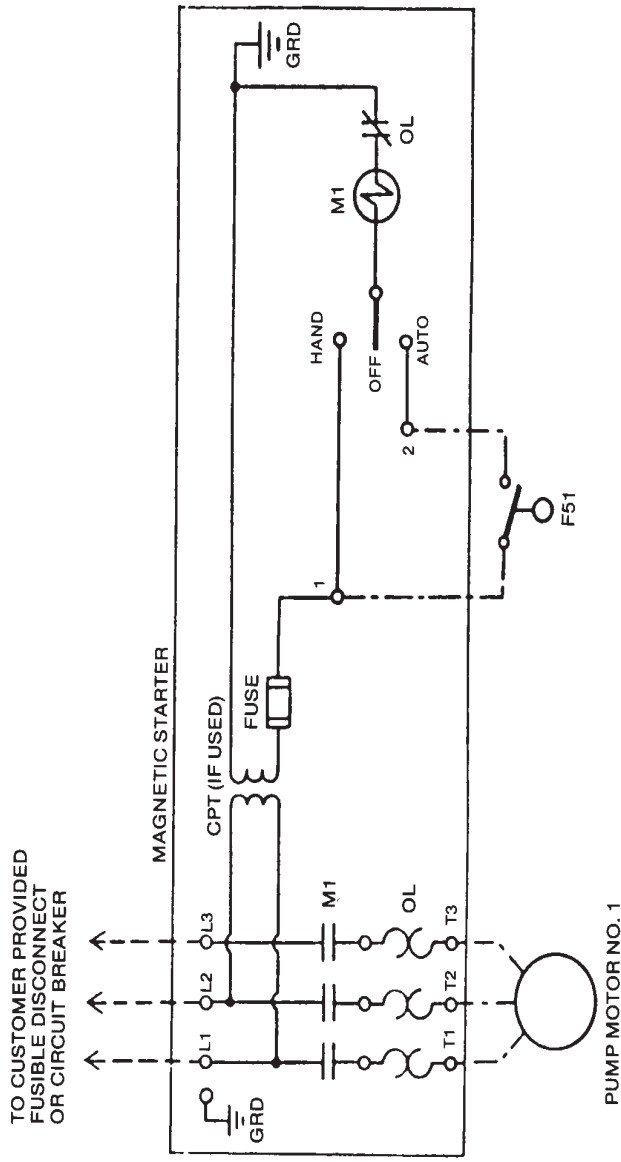

NOMENCLATURE

- M CONTACTOR
- CB CIRCUIT BREAKER
- FS FLOAT SWITCH
- OL MOTOR OVERLOAD RELAY CONTACT
- CPT CONTROL POWER TRANSFORMER
- GRD GROUND

--- WIRING BY OTHERS
 - - - WIRED BY OTHERS EXCEPT PREWIRED WITH FACTORY MOUNTED MOTOR CONTROLS

NOTE 1:

THIS DWG APPLIES TO THE STARTERS PROVIDED BY PACO. IF CUSTOMER PROVIDED MOTOR CONTROL EQUIPMENT IS USED, CONSULT MOTOR CONTROL MANUFACTURER'S LITERATURE FOR SPECIFIC CONNECTION INSTRUCTIONS.

NOTE 2:

3 PHASE LINES SHOWN. FOR SINGLE PHASE, 2 WIRE SUPPLY, "L3" IN CONTROLLER WILL BE OMITTED AND O.L. RELAY WILL BE FURNISHED IN "L1" ONLY. CUSTOMER TO CONNECT 10 LINES TO "L1" & "L2". IF NEUTRAL IS USED, CONNECT TO "L2" TERMINAL.

18604

**DULPLEX MAGNETIC STARTERS WITH
INDIVIDUAL FLOAT SWITCHES**

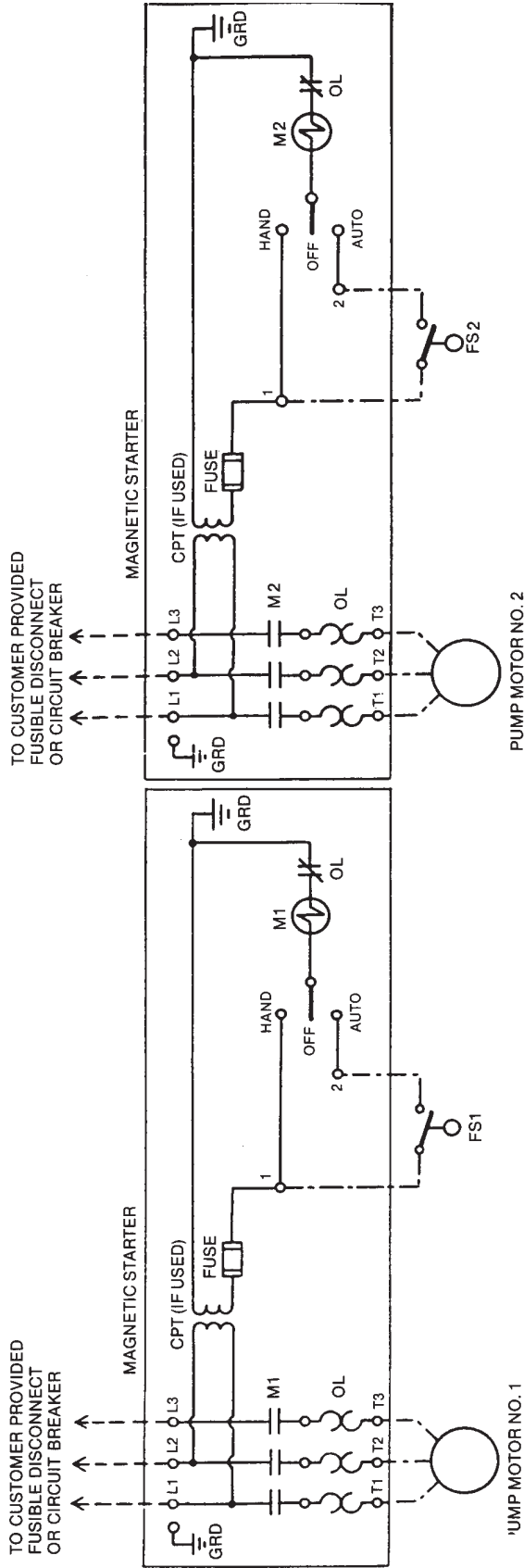

NOMENCLATURE

- M CONTACTOR
- CB CIRCUIT BREAKER
- FS FLOAT SWITCH
- OL MOTOR OVERLOAD RELAY CONTACT
- CPT CONTROL POWER TRANSFORMER
- GRD GROUND

--- WIRING BY OTHERS

--- WIRED BY OTHERS EXCEPT PREWIRED WITH FACTORY MOUNTED MOTOR CONTROLS

NOTE 1: THIS DWG APPLIES TO THE STARTERS PROVIDED BY PACO. IF CUSTOMER PROVIDED MOTOR CONTROL EQUIPMENT IS USED, CONSULT MOTOR CONTROL MANUFACTURER'S LITERATURE FOR SPECIFIC CONNECTION INSTRUCTIONS.

NOTE 2: 3 PHASE LINES SHOWN. FOR SINGLE PHASE, 2 WIRE SUPPLY, "L3" IN CONTROLLER WILL BE OMITTED AND O.L. RELAY WILL BE FURNISHED IN "L1" ONLY. CUSTOMER TO CONNECT TO LINES TO "L1" & "L2". IF NEUTRAL IS USED, CONNECT TO "L2" TERMINAL.

18603

DUPLEX MAGNETIC STARTERS WITH MECHANICAL ALTERNATOR FLOAT SWITCHES

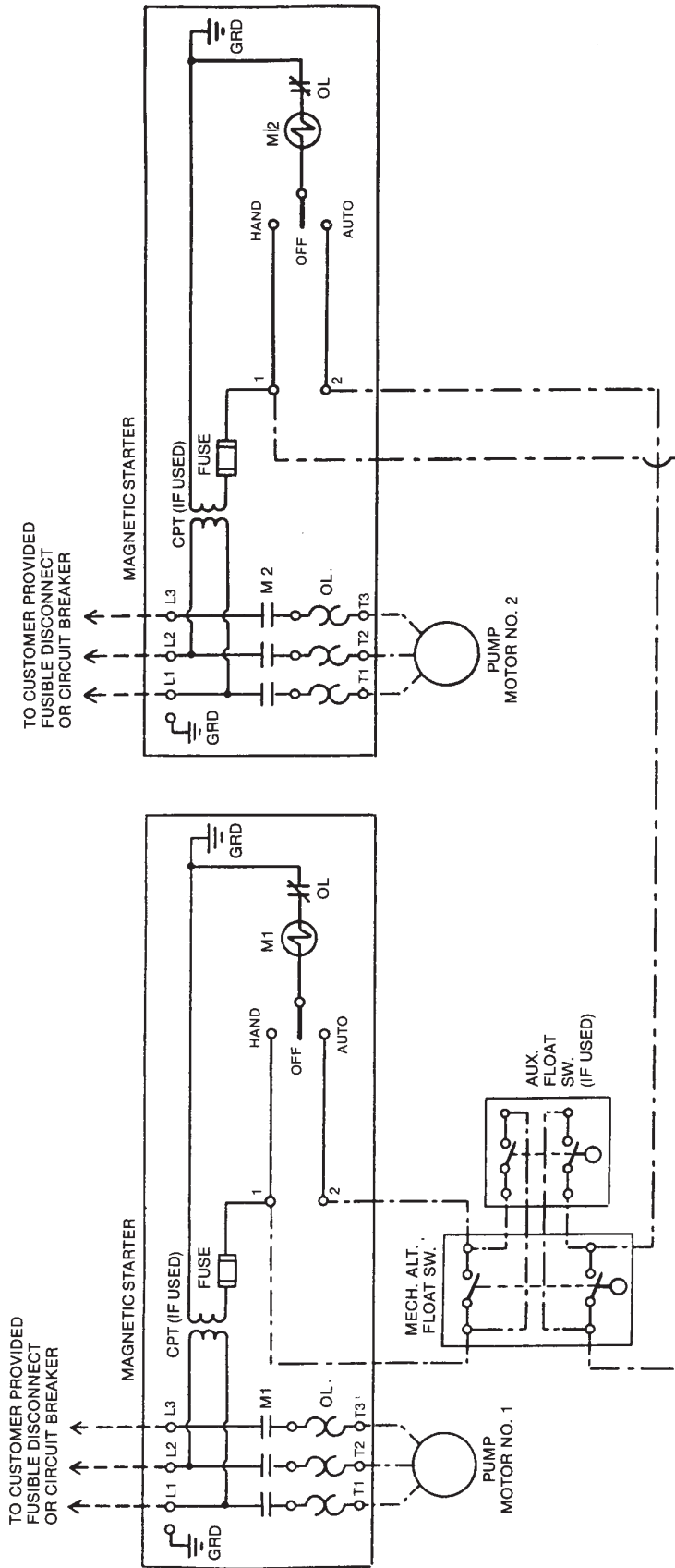

NOMENCLATURE

- M CONTACTOR
- CB CIRCUIT BREAKER
- FS FLOAT SWITCH
- OL MOTOR OVERLOAD RELAY CONTACT
- CPT CONTROL POWER TRANSFORMER
- GRD GROUND
- WIRING BY OTHERS
- - - WIRED BY OTHERS EXCEPT PREWIRED WITH FACTORY MOUNTED MOTOR CONTROLS

NOTE 1:

THIS DWG APPLIES TO THE STARTERS PROVIDED BY PACO. IF CUSTOMER PROVIDED MOTOR CONTROL EQUIPMENT IS USED, CONSULT MOTOR CONTROL MANUFACTURER'S LITERATURE FOR SPECIFIC CONNECTION INSTRUCTIONS.

NOTE 2:

3 PHASE LINES SHOWN. FOR SINGLE PHASE, 2 WIRE SUPPLY, "L3" IN CONTROLLER WILL BE OMITTED AND O.L. RELAY WILL BE FURNISHED IN "L1" ONLY. CUSTOMER TO CONNECT 10 LINES TO "L1" & "L2". IF NEUTRAL IS USED, CONNECT TO "L2" TERMINAL.

18602

Terms And Conditions Of Sale

SECTION 1: THE CONTRACT

The Contract shall be comprised of the following terms, together with such terms and conditions as are set forth in Seller's written proposal or quotation (the "Quotation"), including any documents, drawings or specifications incorporated therein by reference, and any additional or different terms proposed in Buyer's purchase order (the "Purchase Order") that are accepted by Seller in writing, which together shall constitute the entire agreement between the parties, provided, however, that preprinted terms on Buyer's purchase order or invoice shall not apply and Seller gives notice of objection to such terms. An offer by Seller in its Quotation that does not stipulate an acceptance date is not binding. This Contract shall be deemed to have been entered into upon written acknowledgment of the Purchase Order by an officer or authorized representative of Seller, which may not be modified, supplemented, or waived except in a writing executed by an authorized representative of the party to be bound.

SECTION 2: PRICE

The price quoted in the Quotation shall be the Purchase Price unless otherwise agreed in the Purchase Order. The Purchase Price for equipment shall include packing for shipment. Field Services shall be provided at Seller's standard rates. All other costs, including packing for storage, freight, insurance, taxes, customs duties and import/export fees, or any other item not specified in the Contract, shall be paid by Buyer unless separately stated in the Quotation and included in the price quoted. Any sales, use, or other taxes and duties imposed on the transaction or the equipment supplied shall be paid or reimbursed by Buyer.

SECTION 3: PAYMENT TERMS

Payment shall be due within 30 days of the date of Seller's invoice in U.S. funds unless otherwise agreed. If Buyer does not observe the agreed dates of payment, Buyer shall pay interest to Seller on overdue amounts at a rate that is the higher of: 9% per annum or a rate 5% in excess of the rate borne from time to time by new issues of six-month United States Treasury bills. Seller shall be entitled to issue its invoice for the Purchase Price for equipment upon the earlier of shipment, or notice to Buyer that Seller is ready to ship, and for services, upon completion. If the Purchase Price exceeds \$250,000 USD, Buyer shall pay the Purchase Price in Progress payments as follows: Fifteen percent (15%) upon submittal of general arrangement drawings, thirty five percent (35%) after receipt of first Bowl Casting, twenty percent (20%) after first case/bowl hydro test or bowl machining and thirty percent (30%) after notification of ready to ship.

SECTION 4: ACCEPTANCE AND INSPECTION

All equipment shall be finally inspected and accepted by Buyer within 14 days after delivery or such other period of time as is agreed in the Purchase Order. Buyer shall make all claims (including claims for shortages), excepting only those provided for under the warranty clause contained herein, in writing within such 14 day period or they are waived. Services shall be accepted upon completion. Buyer shall not revoke its acceptance. Buyer may reject the equipment only for defects that substantially impair its value, and Buyer's remedy for lesser defects shall be in accordance with Section 10, Warranty. If tests are made by Buyer to demonstrate the ability of the equipment to operate under the contract conditions and to fulfill the warranties in Section 10, Buyer is to make all preparations and incur all expenses incidental to such tests. Seller will have the right of representation at such tests at its expense, and the right to technically direct the operation of the equipment during such tests, including requiring a preliminary run for adjustments.

SECTION 5: TITLE AND RISK OF LOSS

Full risk of loss (including transportation delays and losses) shall pass to Buyer upon delivery, regardless of whether title has passed to Buyer, transport is arranged or supervised by Seller, or start-up is carried out under the direction or supervision of Seller. Delivery shall be ex works, INCOTERMS 2000. Loss or destruction of the equipment or injury or damage to the equipment that occurs while the risk of such loss or damage is borne by Buyer does not relieve Buyer of its obligation to pay Seller for the equipment.

SECTION 6: PATENT OR TRADEMARK INFORMATION

If the equipment sold hereunder is to be prepared or manufactured according to Buyer's specifications, Buyer shall indemnify Seller and hold it harmless from any claims or liability for patent or trademark infringement on account of the sale of such goods.

SECTION 7: CHANGES

Buyer may request, in writing, changes in the design, drawings, specifications, shipping instructions, and shipment schedules of the equipment. As promptly as practicable after receipt of such request, Seller will advise Buyer what amendments to the Contract, if any, may be necessitated by such requested changes, including but not limited to amendment of the Purchase Price, specifications, shipment schedule, or date of delivery. Any changes agreed upon by the parties shall be evidenced by a Change Order signed by both parties.

SECTION 8: CANCELLATION OR TERMINATION

Buyer shall have the right to cancel the Contract upon 15 days' prior written notice to Seller, and Seller shall stop its performance upon the receipt of such notice except as otherwise agreed with Buyer. If Buyer cancels the Contract, it shall pay: (a) the agreed unit price for equipment or components completed and delivered, (b) additional material and labor costs incurred, and for engineering services supplied by Seller with respect to the canceled items, which shall be charged to Buyer at Seller's rates in effect at the time of cancellation, but which shall not exceed the contract price for such items, and (c) such other costs and expenses, including cancellation charges under subcontracts, as Seller may incur in connection with such cancellation or termination.

SECTION 9: DELIVERY AND DELAYS

Seller shall use its best efforts to meet quoted delivery dates, which are estimated based on conditions known at the time

of quotation. Seller shall not be liable for any nonperformance, loss, damage, or delay due to war, riots, fire, flood, strikes or other labor difficulty, governmental actions, acts of God, acts of the Buyer or its customer, delays in transportation, inability to obtain necessary labor or materials from usual sources, or other causes beyond the reasonable control of Seller. In the event of delay in performance due to any such cause, the date of delivery or time for completion will be extended to reflect the length of time lost by reason of such delay. Seller shall not be liable for any loss or damage to Buyer resulting from any delay in delivery.

SECTION 10: WARRANTY

Seller warrants that the equipment or services supplied will be free from defects in material, and workmanship for a period of 12 months from the date of initial operation of the equipment, or 18 months from the date of shipment, whichever shall first occur. In the case of spare or replacement parts manufactured by Seller, the warranty period shall be for a period of six months from shipment. Repairs shall be warranted for 12 months or, if the repair is performed under this warranty, for the remainder of the original warranty period, whichever is less. Buyer shall report any claimed defect in writing to Seller immediately upon discovery and in any event, within the warranty period. Seller shall, at its sole option, repair the equipment or furnish replacement equipment or parts thereof, at the original delivery point. Seller shall not be liable for costs of removal, reinstallation, or gaining access. If Buyer or others repair, replace, or adjust equipment or parts without Seller's prior written approval, Seller is relieved of any further obligation to Buyer under this section with respect to such equipment or parts. The repair or replacement of the equipment or spare or replacement parts by Seller under this section shall constitute Seller's sole obligation and Buyer's sole and exclusive remedy for all claims of defects. SELLER MAKES NO OTHER WARRANTY OR REPRESENTATION OF ANY KIND WITH RESPECT TO THE EQUIPMENT OR SERVICES OTHER THAN AS SPECIFIED IN THIS SECTION 10. ALL OTHER WARRANTIES, EXPRESS OR IMPLIED, INCLUDING BUT NOT LIMITED TO, THE IMPLIED WARRANTIES OF MERCHANTABILITY AND FITNESS FOR A PARTICULAR PURPOSE, ARE HEREBY DISCLAIMED.

For purposes of this Section, the equipment warranted shall not include equipment, parts, and work not manufactured or performed by Seller. With respect to such equipment, parts, or work, Seller's only obligation shall be to assign to Buyer any warranty provided to Seller by the manufacturer or supplier providing such equipment, parts or work.

No equipment furnished by Seller shall be deemed to be defective by reason of normal wear and tear, failure to resist erosive or corrosive action of any fluid or gas, Buyer's failure to properly store, install, operate or maintain the equipment in accordance with good industry practices or specific recommendations of Seller, or Buyer's failure to provide complete and accurate information to Seller concerning the operational application of the equipment.

SECTION 11: TECHNICAL DOCUMENTS

Technical documents furnished by Seller to Buyer, such as drawings, descriptions, designs and the like, shall be deemed provided to Buyer on a confidential basis, shall remain Seller's exclusive property, shall not be provided in any way to third parties, and shall only be used by Buyer for purposes of installation, operation and maintenance. Technical documents submitted in connection with a Quotation that does not result in a Purchase Order shall be returned to Seller upon request.

SECTION 12: LIMITATION OF LIABILITY

Seller shall in no event be liable for any consequential, incidental, indirect, special or punitive damages arising out of the Contract, or out of any breach of any of its obligations hereunder, or out of any defect in, or failure of, or malfunction of the equipment, including but not limited to, claims based upon loss of use, lost profits or revenue, interest, lost goodwill, work stoppage, impairment of other equipment, environmental damage, nuclear incident, loss by reason of shutdown or nonoperation, increased expenses of operation, cost of purchase of replacement power or claims of Buyer or customers of Buyer for service interruption whether or not such loss or damage is based on contract, tort (including negligence and strict liability) or otherwise.

Seller's maximum liability under this Contract shall not exceed the Purchase Order amount of the equipment or portion thereof upon which such liability is based. All such liability shall terminate upon the expiration of the warranty period, if not sooner terminated.

SECTION 13: THIS COMPANY IS AN EQUAL OPPORTUNITY EMPLOYER

This agreement incorporates by reference applicable provisions and requirements of Executive Order 11246 and FAR Section 52.222-26 (covering race, color, religion, sex and national origin); the Vietnam Era Veterans Readjustment Assistance Act of 1974 and FAR Section 52.222-35 (covering special disabled and Vietnam era veterans); and the Rehabilitation Act of 1973 and FAR Section 52.222-36 (covering handicapped individuals). By acceptance of this agreement Buyer certifies that it does not and will not maintain any facilities in a segregated manner, or permit its employees to perform their services at any location under its control where segregated facilities are maintained, and further that appropriate physical facilities are maintained for both sexes. Buyer agrees that it will obtain a similar certificate prior to award of any nonexempt lower-tier subcontracts.

SECTION 14: LAW AND ARBITRATION

The Contract shall be governed by the law of the State of Texas. Any disputes arising out of this Contract shall be resolved by informal mediation in any manner that the parties may agree within 45 days of written request for mediation by one party to the other. Any dispute that cannot be resolved through mediation shall be resolved by binding arbitration conducted in English in Portland, Oregon under the Commercial Rules of the American Arbitration Association except as otherwise provided in this Section. The arbitration shall be conducted by three arbitrators chosen in accordance with said Rules. The arbitrators are not entitled to award damages in excess of compensatory damages. Judgment upon the award may be entered in any court having jurisdiction.

Check our worldwide offices at
www.paco-pumps.com