

**INSTALLATION, OPERATION  
AND MAINTENANCE INSTRUCTIONS  
TYPE NSC & TYPE SM**

**PACO SUBMERSIBLE NON-CLOG PUMPS, TYPE (NSC) D4d.3  
AND  
PACO SUBMERSIBLE SUMP PUMPS, TYPE (SM) D8d.3**

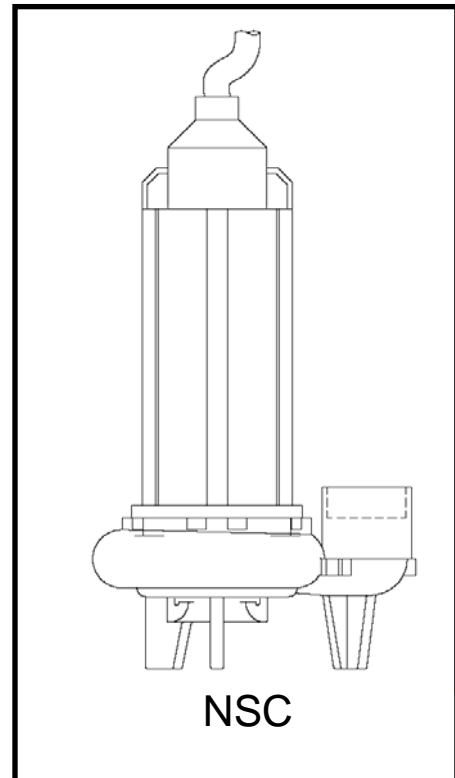
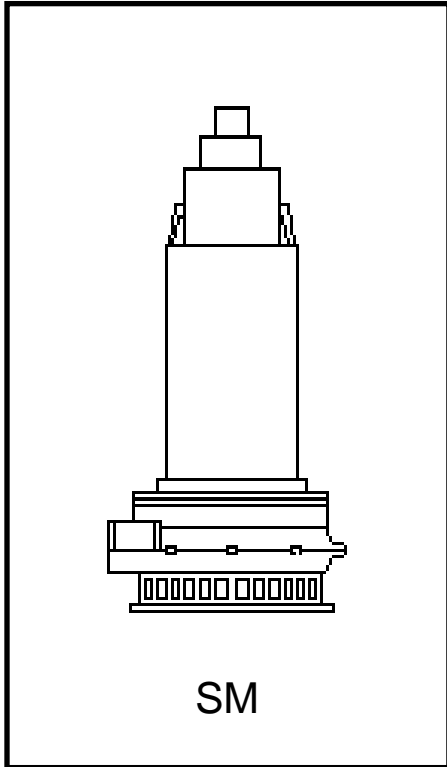

---

**INSTALLATION, OPERATION  
AND MAINTENANCE INSTRUCTIONS  
TYPE NSC & TYPE SM**

---

**TABLE OF CONTENTS**

I. INSTALLATION.....	3
II. OPERATION.....	3
III. DISSASSEMBLY OF PUMPS.....	4
IV. TROUBLE SHOOTING.....	4
V. ORDERING PARTS.....	4

**INSTALLATION, OPERATION  
AND MAINTENANCE INSTRUCTIONS  
TYPE NSC & TYPE SM**

**1. INSTALLATION**

Read these instructions thoroughly before installing and operating your PACO Type SM/NCS Submersible Pump. Successful operation depends on careful attention to the procedures described in this manual. Keep this instruction manual handy for future use.

- a. Pump Identification: All PACO Pumps are identified by Catalog and Serial Numbers. These numbers are stamped on the pump nameplate (Fig. 1) affixed to each pump volute casing, and should be referred to in all correspondence with the Company.

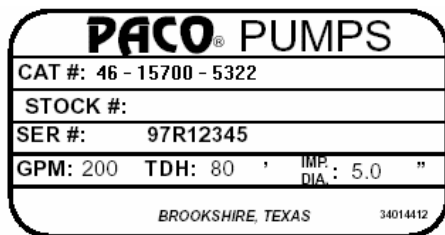

FIG. 1 PUMP NAMEPLATE

- b. Pump is designed to sit on a concrete or metal pump bottom. It should not sit on a dirt bottom.
- c. Pipe discharge to sewer, using a check valve to prevent back-flow. On a duplex installation, use a check valve in each pump discharge line. Locate check valve(s) as far away from pump bottom as possible, to avoid possibility of air binding. Be certain that weight of discharge piping is supported so it does not put a strain on pump casting. End of pipe entering pump discharge flange is to be unthreaded, as special pump flange makes an O-ring seal around it.
- d. Fasten pump chain to sump cover, to provide means of lifting pump when needed. If it becomes necessary to

- replace chain, do not use a smaller size than chain supplied with pump.
- e. Install and adjust liquid level control in accordance with the liquid level control instruction sheet.
- f. Read motor instruction manual and make electrical connections. A third leg overload protection in the starter is recommended as is moisture-sensing controls.
- g. Before starting pump, clean sump of debris, which might clog the pump, such as rags, paper, canvas gloves, blocks of wood.
- h. If motor is three phase, check its direction of rotation by either of the following methods:
  - (1) With pump hanging free of the bottom, and with discharge not connected (but with a piece of burlap wired over it to prevent water discharging too far) turn motor on and then off immediately. As the correct rotation of pump is right hand (clockwise), the "kickback" should be left hand (CCW), looking down on the motor from above it. If it kicks back in wrong direction, interchange any two leads at bottom of entrance switch (after turning off switch first) and try again.
  - (2) Alternate method: Fill sump. Turn pump on and operate it. Note the amount of water pumped out of sump and the time it took. Interchange any two leads at bottom of entrance switch (after turning switch off, first, and marking the leads): fill sump again and try pump again for the same time. The connection which pumps water out at the faster rate is the correct connection, as pump will pump at a much faster rate when running correct rotation than when running backward.

**INSTALLATION, OPERATION  
AND MAINTENANCE INSTRUCTIONS  
TYPE NSC & TYPE SM**

**2. OPERATION**

- a. This motor does not require lubrication attention. Never disassemble the motor.
- b. Water level must be above the motor at all times while operating to provide necessary cooling. While it is permissible to operate pump for a few minutes, manually, to pump the water down as low as possible to clean out the sump or to remove pump, the motor must not operate without water surrounding it completely for more than 15 minutes. Set the level control carefully so that pump shuts off before water starts to uncover top of motor in normal operation.
- c. Check voltage while pump is operating. Voltage must not vary more than 10% from rated voltage stamped on motor nameplate.
- d. Recheck direction of rotation of motor at any time any alterations are made in system wiring.
- e. Do not lift unit by the motor cable, or conduit. Lifting lugs are provided on the unit; use them.

**3. TO DISASSEMBLE THE PUMP**

- a. Remove pump from sump. If necessary to disconnect wiring, mark leads carefully so they will be reconnected in same manner.
- b. To replace impeller, remove volute and remove impeller cap screw and washer. Use wheel or gear pullers to remove impeller or warm impeller slightly with a torch to expand it, and, with two large screwdrivers or small pry bars, one on each side between impeller and backplate, pry carefully and evenly to force impeller off of shaft. **BE VERY CAREFUL TO PRY EVENLY SO AS NOT TO BEND SHAFT.**
- c. Reassemble in reverse order. Under no circumstances should impeller be driven

Disassembly of motor outside of an authorized service shop of the motor manufacturer voids the motor warranty.

on by pounding, as this would damage the seal. Use impeller cap screw to gradually pull impeller onto shaft.

**4. CHECKING FOR TROUBLE**

- a. If pump will not deliver any water, or delivers less water than normal:
  - (1) See that pump is running right hand (CW), looking downward.
  - (2) Check impeller to see that it is not plugged with debris.
  - (3) Check motor nameplate to see that it is correct speed for pump.
  - (4) Check to see that suction screen is not clogged or buried in muck or debris so as to cut down amount of water reaching pump.
  - (5) Check pump operating discharge head. Compare to pump selection head.
- b. If motor overheats, blows fuses, or magnetic switch trips off, check to see that:
  - (1) Voltage is same as stamped on motor nameplate – not any lower. (Power company can check the voltage for you. Be sure to check at time when voltage is usually low, such as evening.)
  - (2) Motor is not faster speed than correct for pump.
  - (3) Head is not lower than unit is selected for. Centrifugal pumps will overload at heads lower than they are selected for, due to pumping increased capacity at lower heads.

**INSTALLATION, OPERATION  
AND MAINTENANCE INSTRUCTIONS  
TYPE NSC & TYPE SM**

- (4) If liquid is heavier than water, motor size must be selected to handle this heavier specific gravity.
- (5) If liquid is more viscous than water, motor size must be selected to handle this greater viscosity.
- (6) Shaft is not bent.
- (7) Impeller is not rubbing on bottom of pump.
- (8) Check heater and fuse selection.

**5. ORDERING PARTS**

- PACO PUMPS has over 90 years of experience in the design, manufacture, and application of centrifugal pumps and pumping systems. PACO's commitment to state-of-the art pump design and quality manufacturing assures maximum user benefits with optimum equipment life at lower cost.
- PACO's commitment to their customers continues through an extensive service organization. Highly trained technicians can assist customers with initial startup, troubleshooting, repair, and system analysis. PACO maintains an extensive stock of replacement parts and part kits for out most popular model pumps. Shipment of these parts is normally made within three days after receipt of an order. On larger pumps, where it is impractical for our factory to inventory low usage parts, replacement parts are normally manufactured and shipped within 15 working days of receipt of an order. In order to reduce pump repair time and shorten inconvenient pump service interruptions, it is suggested that the pump user stock spare parts. For suggested spare parts see Replacement Parts Guide D8b.2, attached, and contact your local PACO Sales Representative (see back cover for the number of your nearest PACO sales office). Since spare parts requirements and quantities vary for specific pump constructions, allow your PACO Representative to help in defining your spare part requirements. To ensure that the proper replacement parts are ordered for your particular pump model, when you call:
  - Identify all pertinent data from the pump nameplate (see Pump Identification). This should always include the pump Catalog or Model Number, and the pump Serial Number.
  - For replacement impellers, also include from the nameplate the operating conditions (GPM and TDH) and the impeller diameter.
  - Identify all parts by item number and description as indicated by the appropriate assembly drawing in this manual, for your particular pump model.

**INSTALLATION, OPERATION  
AND MAINTENANCE INSTRUCTIONS  
TYPE NSC & TYPE SM**

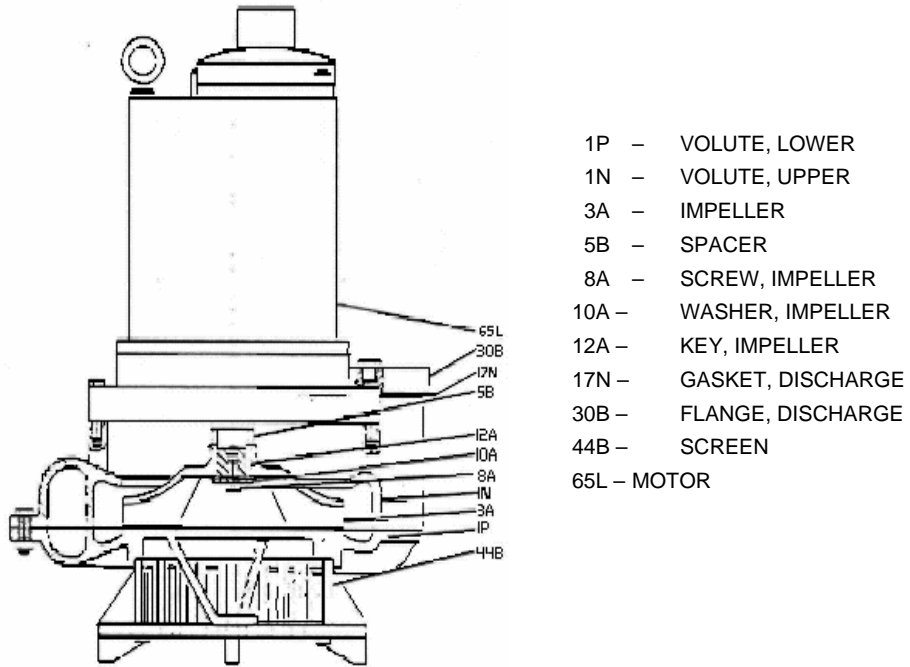

FIG. 2 SUBMERSIBLE SUMP PUMP TYPE "SM"

FIG. 3 SUBMERSIBLE NON-CLOG PUMP TYPE "NSC"

