

**PACO SUMP AND
NON-CLOG PUMPS**

**TYPES SL & NCC
PRODUCT CODES 42, 45, 50, 77**

INSTRUCTION MANUAL

**INSTALLATION
OPERATION
MAINTENANCE**

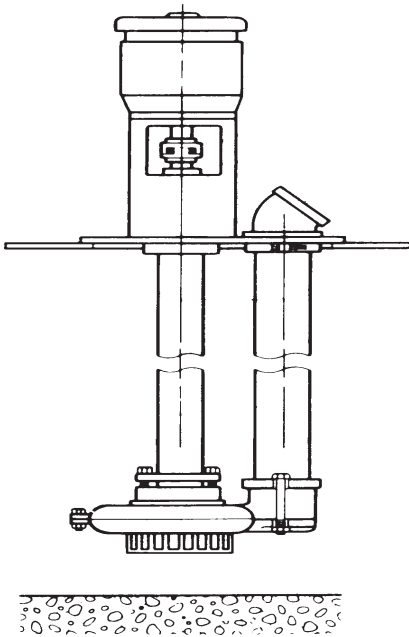

**DUPLEX SUMP PUMP
TYPE SL**

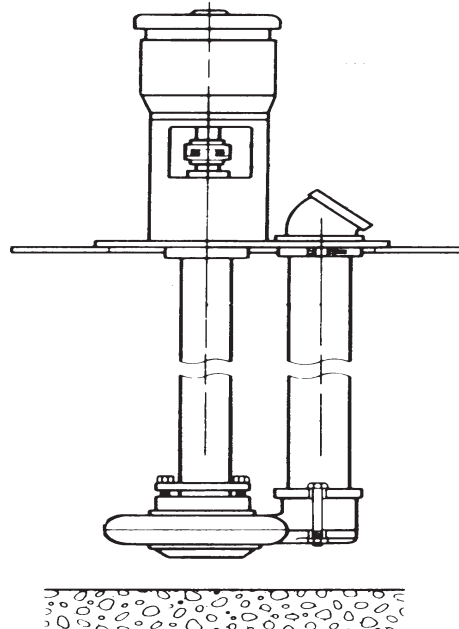

**DUPLEX NON-CLOG PUMP
TYPE NCC**

TABLE OF CONTENTS

I. INSTALLATION-MECHANICAL

A. Pump Identification 3
B. Receiving 3
C. Temporary Storage 3
D. Location 3
E. Installation 4
F. Piping 5
G. External Wiring 5

II. OPERATION

A. Pre-Start Checklist 4
B. Starting The Pump 4
C. Pump Shutdown 5

III. MAINTENANCE

A. Motor Lubrication 5
B. Pump Thrust Bearing Lubrication 6
C. Pump Intermediate & Lower Bearing Lubrication 6

IV. TROUBLESHOOTING

A. Symptoms 7
B. Possible Causes 7

V. WARRANTY 8

VI. SALES AND SERVICE CENTERS 8

I. INSTALLATION

Read these instructions thoroughly before installing and operating your PACO Type ASP and ASP Centrifugal Pump. Successful operation depends on careful attention to the procedures described in Sections 1, 2 and 3 of this manual. Keep this instruction manual handy for future use.

A. PUMP IDENTIFICATION

- All PACO Pumps are identified by Catalog and Serial Numbers. These numbers are stamped on the pump nameplate (Fig.1a) affixed to each pump volute casing, and should be referred to in all correspondence with the Company.

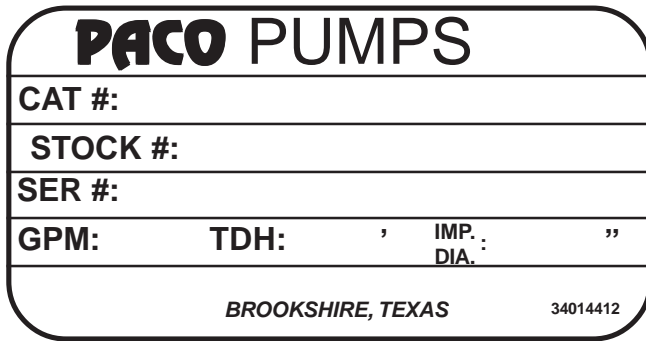

FIGURE 1a

B. RECEIVING

- Check pumping unit for shortage and damage immediately upon arrival. Pump accessories when required are packaged in a separate container and shipped with the unit.
- If equipment is damaged in transit, promptly report this to the carrier's agent. Make complete notations on the freight bill to speed satisfactory adjustment by the carrier.
- Unload and handle the unit with a sling. **Do not lift unit by eye bolts on the motor!**

C. TEMPORARY STORAGE

- If pump is not to be installed and operated soon after arrival, store it in a clean, dry area of moderate ambient temperature.
- Rotate the shaft by hand periodically to coat bearing with lubricant and retard oxidation and corrosion.
- Follow motor manufacturer's storage recommen-

datations where applicable.

D. LOCATION

- Sump should be located so that there is sufficient accessibility for maintenance and inspection of pumping unit. Provide a clear space with ample headroom for use of a hoist strong enough to lift and remove the unit.
- Prior to installation check pump length against sump depth for proper dimension.

E. INSTALLATION

- The pumping unit must be freely suspended from the sump cover or sole plate. The clearance between the pump suction and the bottom of the sump should not be less than one to two times the pump nominal discharge size for optimum performance.
- When a suction strainer is included with a suspended pumping unit a minimum 1/2" clearance between the bottom of the strainer and sump floor is recommended.
- NOTE:** On SL type sump pumps intended for use without sump covers, the unit may be mounted directly on the sump floor.
- Brackets supported from the sump wall may be utilized to retain the unit.

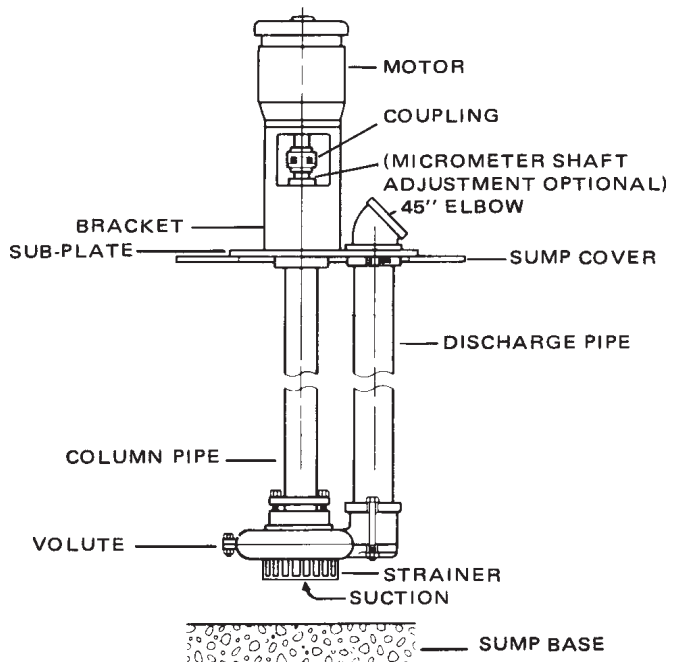

FIGURE 2a: Sump Pump, Type SL

NOTE: REFER TO D1d.3 FOR OPERATION AND INSTALLATION INSTRUCTIONS OF LIQUID LEVEL CONTROLS.

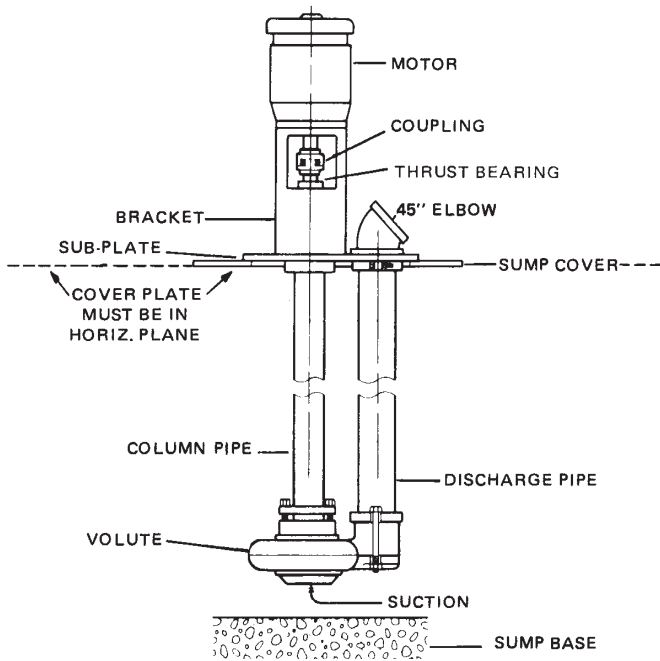

FIGURE 3a: Non-Clog Pump, Type NC

- On a gastight installation, install the length of packing material on the sump flange. Overlap (side by side) the packing ends four to six inches for a complete seal.
- Install sump cover over sump basin in a horizontal plane, and position the cover so that pump subplate opening(s) will place pump discharge piping at required position. Sump cover should be so positioned that the liquid level control parts are not placed directly in the path of the inflow entering sump. Where this is not possible a baffle is required to prevent turbulence of the liquid from interfering with the proper operation of pump and level controls.
- Remove any shipping supports or coverings on the pump unit before installation.
- Install pump and subplate assembly(s) in position on sump cover, using gasket between subplate and sump cover for a gastight installation. Bolt subplate(s) in place.
- Install motor half-coupling on motor (unless the motor is assembled to the unit.)
- **CAUTION:** Do not apply excessive force to install coupling or motor bearings can be damaged.

- Machined face of motor and bracket should be clean. Install coupling insert in position on pump half-coupling (half-couplings should not touch each other.) Assemble motor, on pump bracket with conduit box located as required. Check coupling alignment with straight-edge.
- Refer to appropriate liquid level control instruction sheet for installation and adjustment.
- Bolt manhole plate to cover, using gasket for gastight installation.
- **MICROMETER SHAFT ADJUSTMENT (optional.)**
To raise shaft and impeller, loosen locknut 9A. Holding the shaft, use a spanner wrench, to turn bearing adapter 26H counter-clockwise until impeller makes contact with volute. Then turn bearing adapter clockwise 1/2 to 3/4 of a turn and tighten locknut in position. Check to make certain shaft turns freely. (See Fig. 4a)
- If pump bearing have been specially ordered with clean water lubrication, connect the lines, above sump cover to a clean water supply. If to be manually operated open valve prior to starting unit. Close valve after unit is shut down. On automatic operation, insert a solenoid valve, of same voltage as motor, into clean water supply line, and connect to motor or motor starter to open when motor starts and close when motor stops. Fresh water supply shall be minimum of 10 PSIG above pump discharge pressure at 1-2 GPM.

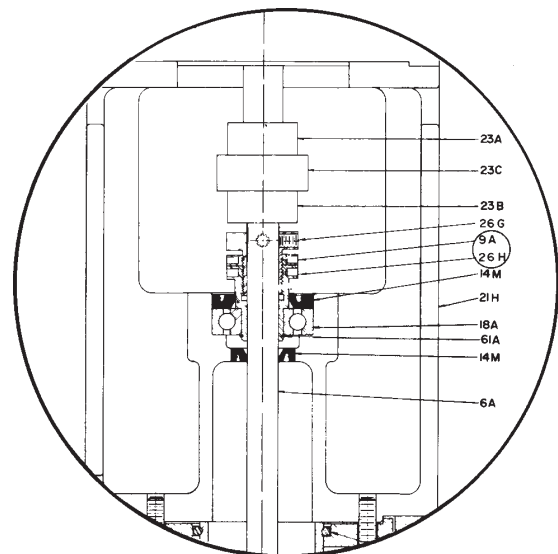

FIGURE 4a: Typical Micrometer Adjustment

F. PIPING GENERAL

- Connect pump discharge and vent piping as required by local code.
- Install a union or flanges in piping at pump, clear of subplate, so complete unit on subplate may be removed readily.
- Discharge piping should be aligned and supported properly so that no strain is transmitted properly so that no strain is transmitted to neither the discharge connection nor the pump assembly.
- Avoid unnecessary bends and fittings in the discharge line. Where necessary, use 45° or long-sweep 90° pipe fittings to decrease friction loss.
- To prevent problems associated with discharge backflow in single or duplex installations, install a check valve in each pump's discharge line. Install a gate valve between each check valve and the header, to facilitate examination or repair of check valve, or removal of pumping unit.

G. EXTERNAL WIRING

- Motor starter(s), with overload protection, must be selected correctly for the motor rating. Follow instructions of motor and starter manufacturers in connecting them and follow wiring diagram for the liquid level control that is contained in its instruction sheet. Be sure that motor overload heaters are properly selected for operating voltage and amperage.
- If atmosphere where motor and/or electrical controls are located is damp, appropriate ventilation and method of keeping the area is dry is essential
- Install electrical wiring in accordance with National Electrical Code Standards and applicable local regulations.
- Check final connections by applying power to motor for an instant, to observe direction of shaft rotation. Shaft must rotate in direction of arrow on pump unit. This is clockwise, looking down on the motor. If rotation is not correct, for three phase motors interchange any two power leads at top or bottom of motor starter. If motor is single phase, refer to the motor wiring diagram.

II. OPERATION

A. PRE-START CHECK LIST

Make the following inspections before starting your PACO type SL or NC Vertical Pump:

- ❑ Make certain that the motor's starter nameplate, voltage, phase and frequency matches the power supply. Check liquid level control wiring diagrams.
- ❑ If motor and pump have been in storage for an extended period, turn shaft by hand to make certain it rotates freely and the motor bearings are properly lubricated per maintenance instructions.
- ❑ Try the motor rotation momentarily to be sure it is correct according to the arrow on the pump (see G-4)

CAUTION: Never run pump dry. Serious damage to unit can result.

- ❑ Check piping to make sure that all connections are tightly made up. All valves open as required.
- ❑ Make certain level controls are in required position.

NOTE: Refer to 1854.615 for operation and installation instructions for level controls.

B. STARTING THE PUMP

- Fill sump with liquid well above pump end, to actuate the high liquid level control.

NOTE: Remove all foreign materials from sump before starting pump.)

- Start the motor if on manual control, or allow level control to start if on automatic control. Run pump through the cycles to insure that float switches are working correctly.
- Check all discharge connections above sump cover for liquid leaks.
- Check and record the voltage, the amperers per phase, and the kilowatts if a wattmeter is available. If voltage is above 10% or below 10% the motor nameplate voltage, shut unit down and check wiring connections. If wiring connections are proper, notify the power company.

- A motor will operate satisfactorily with a voltage variation not exceeding 10% above or below the rating specified on the motor nameplate. Voltages above these limits will cause heavy magnetic saturation of the motor winding and indicate high amperage.
- Being operated by generator, the power supply should not exceed 5% above or below the motor frequency (Hz) rating, for proper performance.

C. PUMP SHUTDOWN

- Cut power to motor(s) or allow low level control to shut unit down.
- If a unit is shut down and the possibility of freezing exists, disconnect the discharge line and take necessary precautions to prevent freezing within the sump.

III. MAINTENANCE

A. MOTOR LUBRICATION

- If the motor is not equipped with grease plugs or grease fittings at its ends (check under the top canopy) it has "sealed bearings", and does not require periodic lubrication.
- If the motor has provision for lubrication of its bearings (grease plugs or grease fittings) follow lubrication instructions furnished with motors.
- If lubrication instructions do not accompany motor, following tables give frequency of greasing and recommended types of grease for motor bearings.

RECOMMENDED FREQUENCY OF LUBRICATION

MOTOR HP	OPERATING CONDITIONS		
	STANDARD	SEVERE	EXTREME
1/3 7-1/2	3 yrs.	1 yr.	6 mos.
10-40	1-3 yrs.	1/2 1 yr.	3 mos.
50 & UP	1 yr.	6 mos.	3 mos.

TABLE 5a

B. PUMP THRUST BEARING LUBRICATION

- These bearings are integrally sealed and lubricated for life. No further lubrication required.

Standard Operating Conditions: 8 hours a day, clean atmosphere, motor not overloaded, 100° F. max. ambient temperature. **Severe Operating Conditions:** 24 hours a day, 100° F. to 150° F. ambient temperature; dirty or dusty. **Extreme Operating Conditions:** Very heavy dust or dirt.

RECOMMENDED TYPES OF GREASE FOR BALL BEARINGS

Manufacturer	Lubricant
Exxon	Andok B
Standard Oil of California	Chevron BRB2
Shell Oil co.	Alvania EP2
Texaco, Inc.	Regal Starfak #2
Mobil Oil Co.	Mobilux Grease #2

TABLE 6a

C. PUMP INTERMEDIATE AND LOWER BEARING LUBRICATION

- Self-lubricating intermediate bearing bushings are normally furnished. For those pumps furnished with grease lines to intermediate bearings, inject a lubricant selected from Table IIIb into grease-line fitting (s). Lubricate daily for continuously operating pumps to once a month for intermittent pump operation.
- Lower bearing normally is lubricated by the liquid pumped. If lower bearing has been specially ordered with a grease line, lubricate per C-1.
- If pump bearings have been specially ordered with clean water lubrication, connect the lines, above sump cover to a clean water supply. If to be manually operated open valve prior to starting unit. Close valve after unit is shut down. On automatic operation, insert a solenoid valve, of same voltage as motor, into clean water supply line, and connect to motor or motor starter to open when motor starts and close when motor stops. Fresh water supply shall be a minimum of 10 PSIG above pump discharge pressure at 1-2 GPM.
- **IMPORTANT:** Most codes do not permit cross-connection of water supply for a sump pump bearing to a potable water supply. A PACO Water Seal Unit should be installed. This is a small pump unit with tank and water float valve, providing an air gap between the water source and the water use. It can be wired to start and stop with the pump motor.

IV. TROUBLE-SHOOTING CHECKLIST

**A. PUMP DOES NOT DELIVER ENOUGH LIQUID:
OR DELIVERS INSUFFICIENT PRESSURE.**

- **IMPELLER ADJUSTED TOO HIGH**
Refer to installation instructions, paragraph E-10, and check that height of impeller off bottom of pump volute does not exceed recommended clearance.
- **DISCHARGE PIPING LEAKS**
Check piping within sump and to point of discharge to make certain there is no loss due to liquid leaks.
- **AIR OR GASES IN LIQUID**
Capacity is reduced if liquid flow into sump entrains air, or if liquid contains air or gases. Baffles can be inserted in sump to decrease entrainment of air by cascading liquid. A gas-separation chamber and release valve in line to sump may be required.
- **VORTEX IN SUMP**
Check minimum level control operation. Adjust control to allow ample submergence in sump to prevent vortexing. (Swirling eddies which will pull air into pump suction.
- **HIGH OR LOW VOLTAGE**
Check to see that the voltage is not more than 10% different than motor nameplate rated voltage. Low or high voltage will cause excessive current draw.
- **MOTOR SPEED**
Check motor nameplate to be certain that the motor RPM is correct for pump.
- **LOW DISCHARGE HEAD**
Check total discharge head. If it is appreciably less than specified condition, check pump performance curve to see if reduction in the impeller diameter may be required. Greatly increased capacity due to low discharge head can result in increased load on the motor.
- **HIGH DISCHARGE HEAD**
Check total discharge head in the system. If it is appreciably higher than specified condition, check pump performance curve to see if pump is capable of delivering required head. If specified head is too low, replacement of pump with a larger unit may be necessary.
- **ADJUSTED TOO LOW**
With pump shut down rotate shaft by hand to check for impeller drag on bottom of volute. If interference is noted, readjust impeller per installation instructions paragraph E-10.

- **LIQUID TOO HEAVY OR VISCOUS**
Refer to the Company with full details of the liquid, including temperature, specific gravity, and viscosity. A change of motor and/or impeller, or of pump end, may be required.
- **MISALIGNMENT**
Examine for possibility of shaft and column damage during transit or during handling in storage and installation. A bent shaft will draw excess power and cause vibration and bearing wear.
- **DISTORTION**
Check discharge column pipe for plumb installation in the sump. Eliminate any stress on the volute or column pipe.

B. PUMP IS NOISY OR VIBRATES

- **BALL BEARING ROUGH**
Will power off, rotate shaft by hand to determine if a ball bearing feels rough.

During operation check pump thrust bearing and both motor ball bearings for noise or vibration. Maximum vibration limit is .005 mils.
- **BENT SHAFT:**
See Misalignment (par. 11 above.)
- **WORN BOTTOM OF INTERMEDIATE BEARINGS**
Disassemble pump and inspect bearing bushings, and shaft sleeves if shaft is so equipped at intermediate bearings. Replace if needed. Check shaft for straightness.
- Recheck pump rotation (see G-4.)

Terms And Conditions Of Sale

SECTION 1: THE CONTRACT

The Contract shall be comprised of the following terms, together with such terms and conditions as are set forth in Seller's written proposal or quotation (the "Quotation"), including any documents, drawings or specifications incorporated therein by reference, and any additional or different terms proposed in Buyer's purchase order (the "Purchase Order") that are accepted by Seller in writing, which together shall constitute the entire agreement between the parties, provided, however, that preprinted terms on Buyer's purchase order or invoice shall not apply and Seller gives notice of objection to such terms. An offer by Seller in its Quotation that does not stipulate an acceptance date is not binding. This Contract shall be deemed to have been entered into upon written acknowledgment of the Purchase Order by an officer or authorized representative of Seller, which may not be modified, supplemented, or waived except in a writing executed by an authorized representative of the party to be bound.

SECTION 2: PRICE

The price quoted in the Quotation shall be the Purchase Price unless otherwise agreed in the Purchase Order. The Purchase Price for equipment shall include packing for shipment. Field Services shall be provided at Seller's standard rates. All other costs, including packing for storage, freight, insurance, taxes, customs duties and import/export fees, or any other item not specified in the Contract, shall be paid by Buyer unless separately stated in the Quotation and included in the price quoted. Any sales, use, or other taxes and duties imposed on the transaction or the equipment supplied shall be paid or reimbursed by Buyer.

SECTION 3: PAYMENT TERMS

Payment shall be due within 30 days of the date of Seller's invoice in U.S. funds unless otherwise agreed. If Buyer does not observe the agreed dates of payment, Buyer shall pay interest to Seller on overdue amounts at a rate that is the higher of: 9% per annum or a rate 5% in excess of the rate borne from time to time by new issues of six-month United States Treasury bills. Seller shall be entitled to issue its invoice for the Purchase Price for equipment upon the earlier of shipment, or notice to Buyer that Seller is ready to ship, and for services, upon completion. If the Purchase Price exceeds \$250,000 USD, Buyer shall pay the Purchase Price in Progress payments as follows: Fifteen percent (15%) upon submittal of general arrangement drawings, thirty five percent (35%) after receipt of first Bowl Casting, twenty percent (20%) after first case/bowl hydro test or bowl machining and thirty percent (30%) after notification of ready to ship.

SECTION 4: ACCEPTANCE AND INSPECTION

All equipment shall be finally inspected and accepted by Buyer within 14 days after delivery or such other period of time as is agreed in the Purchase Order. Buyer shall make all claims (including claims for shortages), excepting only those provided for under the warranty clause contained herein, in writing within such 14 day period or they are waived. Services shall be accepted upon completion. Buyer shall not revoke its acceptance. Buyer may reject the equipment only for defects that substantially impair its value, and Buyer's remedy for lesser defects shall be in accordance with Section 10, Warranty. If tests are made by Buyer to demonstrate the ability of the equipment to operate under the contract conditions and to fulfill the warranties in Section 10, Buyer is to make all preparations and incur all expenses incidental to such tests. Seller will have the right of representation at such tests at its expense, and the right to technically direct the operation of the equipment during such tests, including requiring a preliminary run for adjustments.

SECTION 5: TITLE AND RISK OF LOSS

Full risk of loss (including transportation delays and losses) shall pass to Buyer upon delivery, regardless of whether title has passed to Buyer, transport is arranged or supervised by Seller, or start-up is carried out under the direction or supervision of Seller. Delivery shall be ex works, INCOTERMS 2000. Loss or destruction of the equipment or injury or damage to the equipment that occurs while the risk of such loss or damage is borne by Buyer does not relieve Buyer of its obligation to pay Seller for the equipment.

SECTION 6: PATENT OR TRADEMARK INFORMATION

If the equipment sold hereunder is to be prepared or manufactured according to Buyer's specifications, Buyer shall indemnify Seller and hold it harmless from any claims or liability for patent or trademark infringement on account of the sale of such goods.

SECTION 7: CHANGES

Buyer may request, in writing, changes in the design, drawings, specifications, shipping instructions, and shipment schedules of the equipment. As promptly as practicable after receipt of such request, Seller will advise Buyer what amendments to the Contract, if any, may be necessitated by such requested changes, including but not limited to amendment of the Purchase Price, specifications, shipment schedule, or date of delivery. Any changes agreed upon by the parties shall be evidenced by a Change Order signed by both parties.

SECTION 8: CANCELLATION OR TERMINATION

Buyer shall have the right to cancel the Contract upon 15 days' prior written notice to Seller, and Seller shall stop its performance upon the receipt of such notice except as otherwise agreed with Buyer. If Buyer cancels the Contract, it shall pay: (a) the agreed unit price for equipment or components completed and delivered, (b) additional material and labor costs incurred, and for engineering services supplied by Seller with respect to the canceled items, which shall be charged to Buyer at Seller's rates in effect at the time of cancellation, but which shall not exceed the contract price for such items, and (c) such other costs and expenses, including cancellation charges under subcontracts, as Seller may incur in connection with such cancellation or termination.

SECTION 9: DELIVERY AND DELAYS

8 Seller shall use its best efforts to meet quoted delivery dates, which are estimated based on conditions known at the time

of quotation. Seller shall not be liable for any nonperformance, loss, damage, or delay due to war, riots, fire, flood, strikes or other labor difficulty, governmental actions, acts of God, acts of the Buyer or its customer, delays in transportation, inability to obtain necessary labor or materials from usual sources, or other causes beyond the reasonable control of Seller. In the event of delay in performance due to any such cause, the date of delivery or time for completion will be extended to reflect the length of time lost by reason of such delay. Seller shall not be liable for any loss or damage to Buyer resulting from any delay in delivery.

SECTION 10: WARRANTY

Seller warrants that the equipment or services supplied will be free from defects in material, and workmanship for a period of 12 months from the date of initial operation of the equipment, or 18 months from the date of shipment, whichever shall first occur. In the case of spare or replacement parts manufactured by Seller, the warranty period shall be for a period of six months from shipment. Repairs shall be warranted for 12 months or, if the repair is performed under this warranty, for the remainder of the original warranty period, whichever is less. Buyer shall report any claimed defect in writing to Seller immediately upon discovery and in any event, within the warranty period. Seller shall, at its sole option, repair the equipment or furnish replacement equipment or parts thereof, at the original delivery point. Seller shall not be liable for costs of removal, reinstallation, or gaining access. If Buyer or others repair, replace, or adjust equipment or parts without Seller's prior written approval, Seller is relieved of any further obligation to Buyer under this section with respect to such equipment or parts. The repair or replacement of the equipment or spare or replacement parts by Seller under this section shall constitute Seller's sole obligation and Buyer's sole and exclusive remedy for all claims of defects. SELLER MAKES NO OTHER WARRANTY OR REPRESENTATION OF ANY KIND WITH RESPECT TO THE EQUIPMENT OR SERVICES OTHER THAN AS SPECIFIED IN THIS SECTION 10. ALL OTHER WARRANTIES, EXPRESS OR IMPLIED, INCLUDING BUT NOT LIMITED TO, THE IMPLIED WARRANTIES OF MERCHANTABILITY AND FITNESS FOR A PARTICULAR PURPOSE, ARE HEREBY DISCLAIMED.

For purposes of this Section, the equipment warranted shall not include equipment, parts, and work not manufactured or performed by Seller. With respect to such equipment, parts, or work, Seller's only obligation shall be to assign to Buyer any warranty provided to Seller by the manufacturer or supplier providing such equipment, parts or work.

No equipment furnished by Seller shall be deemed to be defective by reason of normal wear and tear, failure to resist erosive or corrosive action of any fluid or gas, Buyer's failure to properly store, install, operate or maintain the equipment in accordance with good industry practices or specific recommendations of Seller, or Buyer's failure to provide complete and accurate information to Seller concerning the operational application of the equipment.

SECTION 11: TECHNICAL DOCUMENTS

Technical documents furnished by Seller to Buyer, such as drawings, descriptions, designs and the like, shall be deemed provided to Buyer on a confidential basis, shall remain Seller's exclusive property, shall not be provided in any way to third parties, and shall only be used by Buyer for purposes of installation, operation and maintenance. Technical documents submitted in connection with a Quotation that does not result in a Purchase Order shall be returned to Seller upon request.

SECTION 12: LIMITATION OF LIABILITY

Seller shall in no event be liable for any consequential, incidental, indirect, special or punitive damages arising out of the Contract, or out of any breach of any of its obligations hereunder, or out of any defect in, or failure of, or malfunction of the equipment, including but not limited to, claims based upon loss of use, lost profits or revenue, interest, lost goodwill, work stoppage, impairment of other equipment, environmental damage, nuclear incident, loss by reason of shutdown or nonoperation, increased expenses of operation, cost of purchase of replacement power or claims of Buyer or customers of Buyer for service interruption whether or not such loss or damage is based on contract, tort (including negligence and strict liability) or otherwise.

Seller's maximum liability under this Contract shall not exceed the Purchase Order amount of the equipment or portion thereof upon which such liability is based. All such liability shall terminate upon the expiration of the warranty period, if not sooner terminated.

SECTION 13: THIS COMPANY IS AN EQUAL OPPORTUNITY EMPLOYER

This agreement incorporates by reference applicable provisions and requirements of Executive Order 11246 and FAR Section 52.222-26 (covering race, color, religion, sex and national origin); the Vietnam Era Veterans Readjustment Assistance Act of 1974 and FAR Section 52.222-35 (covering special disabled and Vietnam era veterans); and the Rehabilitation Act of 1973 and FAR Section 52.222-36 (covering handicapped individuals). By acceptance of this agreement Buyer certifies that it does not and will not maintain any facilities in a segregated manner, or permit its employees to perform their services at any location under its control where segregated facilities are maintained, and further that appropriate physical facilities are maintained for both sexes. Buyer agrees that it will obtain a similar certificate prior to award of any nonexempt lower-tier subcontracts.

SECTION 14: LAW AND ARBITRATION

The Contract shall be governed by the law of the State of Texas. Any disputes arising out of this Contract shall be resolved by informal mediation in any manner that the parties may agree within 45 days of written request for mediation by one party to the other. Any dispute that cannot be resolved through mediation shall be resolved by binding arbitration conducted in English in Portland, Oregon under the Commercial Rules of the American Arbitration Association except as otherwise provided in this Section. The arbitration shall be conducted by three arbitrators chosen in accordance with said Rules. The arbitrators are not entitled to award damages in excess of compensatory damages. Judgment upon the award may be entered in any court having jurisdiction.

Check our worldwide offices at
www.paco-pumps.com