

CAUTION
Model 293 should not be subjected to less than 15' TDH.

**Single Seal Automatic Design
Weight 86-89 lbs.**

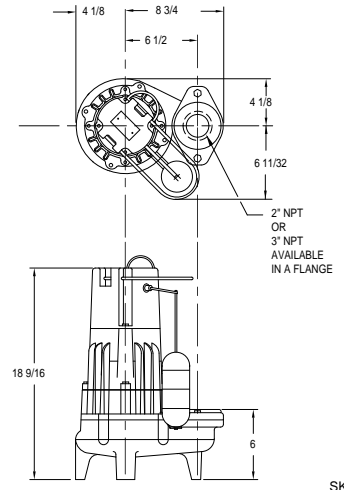

SK863

292 MODELS	4292 MODELS	Standard all models - 20 ft. cord - 1/2 HP				Control Selection		Listings	
Single Seal	Double Seal	Volts - Ph	Mode	Amps	Simplex	Duplex	CSA	UL	
M292	---	115	1	Auto	15.0	1	---	Y Y	
N292	N4292	115	1	Non	15.0	2 or 3	2 or 4	Y Y ⁽¹⁾	

293 MODELS	4293 MODELS	Standard all models - 20 ft. cord - 1 HP				Control Selection		Listings	
Single Seal	Double Seal	Volts - Ph	Mode	Amps	Simplex	Duplex	CSA	UL	
D293	---	230	1	Auto	10.2	1	---	Y Y	
E293	E4293	230	1	Non	10.2	2 or 3	4	Y Y	
* H293	---	200	1	Auto	12.0	1	---	Y N	
* I 293	* I 4293	200	1	Non	12.0	2 or 3	4	Y N	
* F293	* F4293	230	3	Non	7.6	3	4	Y Y	
* J293	* J4293	200	3	Non	8.2	3	4	Y Y	
* G293	* G4293	460	3	Non	4.0	3	4	Y Y	
* BA293	---	575	3	Non	3.3	3	4	Y N	

294 MODELS	4294 MODELS	Standard all models - 20 ft. cord - 1 1/2 HP				Control Selection		Listings	
Single Seal	Double Seal	Volts - Ph	Mode	Amps	Simplex	Duplex	CSA	UL	
D294	---	230	1	Auto	13.7	1	---	Y Y ⁽¹⁾	
E294	E4294	230	1	Non	13.7	2 or 3	4	Y Y ⁽¹⁾	
* H294	---	200	1	Auto	17.8	1	---	Y N	
* I 294	* I 4294	200	1	Non	17.8	2 or 3	4	Y N	
* F294	* F4294	230	3	Non	9.5	3	4	Y Y	
* J294	* J4294	200	3	Non	10.8	3	4	Y Y	
* G294	* G4294	460	3	Non	4.8	3	4	Y Y	
* BA294	---	575	3	Non	3.8	3	4	Y N	

295 MODELS	4295 MODELS	Standard all models - 20 ft. cord - 2 HP				Control Selection		Listings	
Single Seal	Double Seal	Volts - Ph	Mode	Amps	Simplex	Duplex	CSA	UL	
D295	---	230	1	Auto	17.1	1	---	Y ⁽²⁾ Y	
E295	E4295	230	1	Non	17.1	2 or 3	4	Y ⁽²⁾ Y	
WD295	---	230	1	Auto	17.1	**	4	N N	
* H295	---	200	1	Auto	20.5	1	---	Y N	
* I 295	* I 4295	200	1	Non	20.5	2 or 3	4	Y N	
* F295	* F4295	230	3	Non	12.2	3	4	Y Y	
* J295	* J4295	200	3	Non	14.3	3	4	Y Y	
* G295	* G4295	460	3	Non	6.1	3	4	Y Y	
* BA295	---	575	3	Non	4.9	3	4	Y N	

* No Molded Plug.
** Single piggyback switch included.
(1) UL Listed unit available with 20 Amp plug.
(2) CSA Approval with 20 Amp plug.

Double Seal Design / Weight 92-95 lbs.

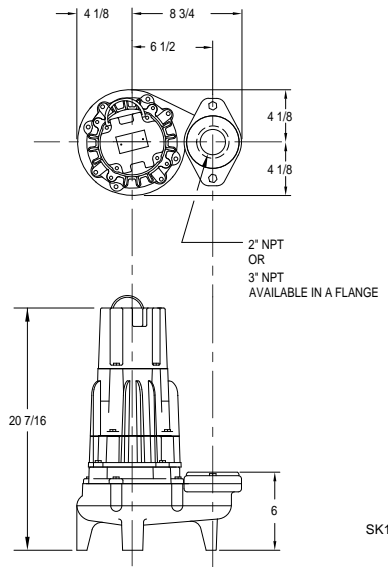

SK1415

SELECTION GUIDE

1. Integral float operated mechanical switch, no external control required.
2. For automatic use single piggyback variable level float switch or double piggyback variable level float switch. Refer to FM0477.
3. See FM1228 for correct model of simplex control panel.
4. See FM0712 for correct model of duplex control panel.

CAUTION

All installation of controls, protection devices and wiring should be done by a qualified licensed electrician. All electrical and safety codes should be followed including the most recent National Electrical Code (NEC) and the Occupational Safety and Health Act (OSHA).

For information on additional Zoeller products refer to catalog on Explosion Proof Models, FM1702; Simplex controls, FM1596; Piggyback Variable Level Float Switches, FM0477; Electrical Alternator, FM0486; Mechanical Alternator, FM0495; Sump/Sewage Basins, FM0487; Alarm Systems, FM0732; Disconnect/Rail Systems, FM0787; and Junction Boxes FM1597.

RESERVE POWERED DESIGN

For unusual conditions a reserve safety factor is engineered into the design of every Zoeller pump.
© Copyright 2009 Zoeller Co. All rights reserved.