

"QUALITY PUMPS SINCE 1939"

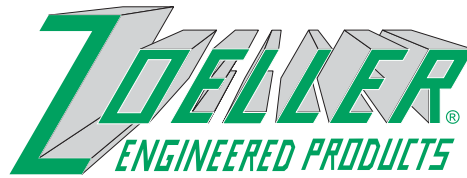

Z1.10.110
ZM1372
0810
Supersedes
0909

Product information presented here reflects conditions at time of publication. Consult factory regarding discrepancies or inconsistencies.

MAIL TO: P.O. BOX 16347 • Louisville, KY 40256-0347
SHIP TO: 3649 Cane Run Road • Louisville, KY 40211-1961
(502) 778-2731 • 1 (800) 928-PUMP • FAX (502) 774-3624

visit our web site:
www.zoeller.com



Tested to UL Standard UL778.



Certified to CSA Standard C22.2 No.108.

PERFORMANCE DATA COMMERCIAL EFFLUENT PUMPS MODELS 6161, 6163, 6165



GENERAL DATA

	<input type="checkbox"/> 6161	<input type="checkbox"/> 6163	<input type="checkbox"/> 6165
PUMP NAME PLATE HORSEPOWER:	½ HP	½ HP	1 HP
SOLID SIZE: in (mm)	¾" (19mm)	¾" (19mm)	¾" (19mm)
MINIMUM HEAD: ft. (m)	5.0' (1.5m)	5.0' (1.5m)	5.0' (1.5m)
MAXIMUM HEAD: ft. (m)	56' (17.1m)	66' (20.1m)	86.5' (26.4m)
MAX.FLOW GPM (L/min) @ MIN. HEAD ft. (m)	100 GPM @ 5' (379 L/min @ 1.5m)	61 GPM @ 5' (231 L/min @ 1.5m)	61 GPM @ 5' (231 L/min @ 1.5m)
DISCHARGE SIZE: VERTICAL FEMALE	<input type="checkbox"/> 1½" NPT <input type="checkbox"/> 2" NPT <input type="checkbox"/> 3" NPT	<input type="checkbox"/> 1½" NPT <input type="checkbox"/> 2" NPT <input type="checkbox"/> 3" NPT	<input type="checkbox"/> 1½" NPT <input type="checkbox"/> 2" NPT <input type="checkbox"/> 3" NPT

PUMP NET WEIGHT: lbs (kg)	87 lbs (318 kg)	MOTOR TYPE:	SUBMERSIBLE
SERVICE FACTOR:	1.15	TYPE SOW POWER CORD LENGTH: ft (m)	25' (7.62m) <input type="checkbox"/> _____'
MOTOR DESIGN LETTER:	NEMA B	MOTOR SHAFT:	416 S.S.
IMPELLER TYPE:	BRONZE VORTEX	STATOR INSULATION:	CLASS B
O-RINGS AND COVER GASKET:	VITON	LEAD WIRES INSULATION:	CLASS B
RPM:	3450	MAXIMUM STATOR TEMPERATURE:	266°F (130°C)

SHAFT SEAL CONSTRUCTION:	STANDARD	UPPER-CARBON/CERAMIC, LOWER-SILICON CARBIDE/ CARBON
	OPTIONAL <input type="checkbox"/> UPPER <input type="checkbox"/> LOWER	<input type="checkbox"/> SILICON CARBIDE / CARBON <input type="checkbox"/> SILICON CARBIDE / SILICON CARBIDE <input type="checkbox"/> SILICON CARBIDE / SILICON CARBIDE
MOTOR THERMAL SHUTOFF:	STANDARD (Single Phase Only)	THERMAL OVERLOAD SENSORS WITH AUTOMATIC RESET
MOISTURE DETECTION:	<input type="checkbox"/> OPTIONAL*	MOISTURE SENSING PROBES
MINIMUM RECOMMENDED FLUID LEVEL: in (m)		10" (0.25m)
MAXIMUM WATER TEMPERATURE:		<input type="checkbox"/> 130°F (54°C)

*Requires a circuit in control panel to function.
**See back side for listed UL and CSA models.

ELECTRICAL DATA

MODEL	HP	<input type="checkbox"/> 115V/1Ph		<input type="checkbox"/> 200V/1Ph		<input type="checkbox"/> 230V/1Ph		<input type="checkbox"/> 200V/3Ph		<input type="checkbox"/> 230V/3Ph		<input type="checkbox"/> 460V/3Ph		<input type="checkbox"/> 575V/3Ph	
		FLA	LRA	FLA	LRA	FLA	LRA	FLA	LRA	FLA	LRA	FLA	LRA	FLA	LRA
<input type="checkbox"/> 6161	½	15.5	31.2	8.8	16.7	7.5	15.6	6.4	23.0	5.2	12.5	2.9	12.4	2.4	11.3
<input type="checkbox"/> 6163	½	15.0	31.2	8.5	16.7	7.5	15.6	6.0	23.0	4.8	12.5	2.9	12.4	2.4	11.3
<input type="checkbox"/> 6165	1	--	--	12.6	26.9	10.2	19.0	7.5	30.0	7.4	14.0	3.7	14.0	3.0	14.4

Refer to reverse side for Head/Capacity Performance Curves

© Copyright 2010 Zoeller Co. All rights reserved.

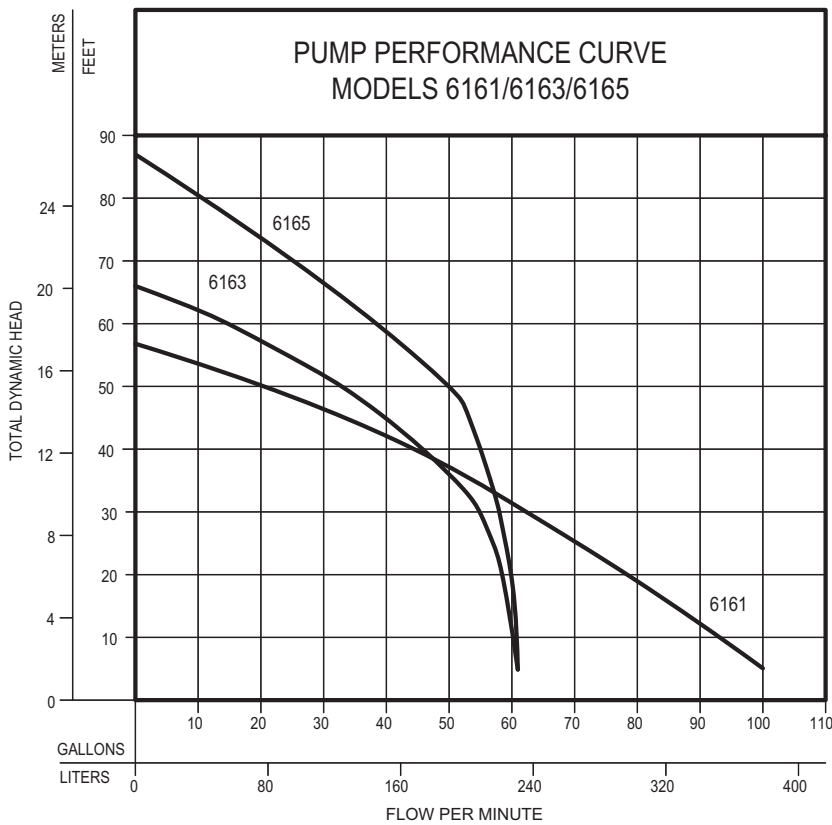

MODELS		6161		6163		6165	
Feet	Meters	Gal.	Liters	Gal.	Liters	Gal.	Liters
5	1.5	100	379	61	231	61	231
10	3.0	93	352	61	231	61	231
15	4.6	85	322	60	227	61	231
20	6.1	79	297	59	223	60	227
25	7.6	70	265	57	216	59	223
30	9.1	62	233	55	206	58	220
40	12.2	45	170	46	172	55	208
50	15.2	20	76	33	125	50	189
60	18.3	--	--	15	57	39	148
70	21.3	--	--	--	--	23	87
80	24.4	--	--	--	--	10	38
Shut-off Head:		56 ft. (17m)		66 ft. (20m)		86.5 ft. (26m)	

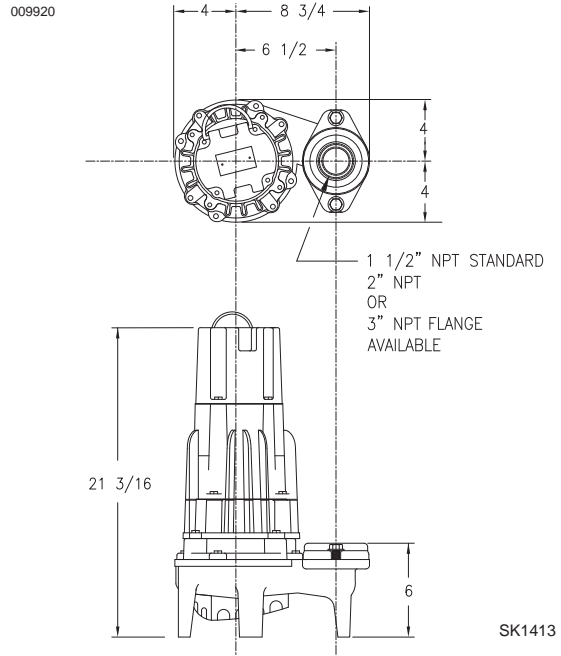

FEATURES

- Durable Epoxy Coated cast iron construction
- Motor - 1/2 HP or 1 HP, 60 Hz, 3450 RPM, 1 PH or 3 PH, oil filled, hermetically sealed, automatic reset, thermal overload protected (1 PH)
- Bearings - Upper and lower ball bearings
- Stainless Steel Motor Shaft
- Dual Mechanical Shaft Seals - Upper carbon/ceramic, Lower silicon carbide/carbon. Optional seal materials available
- Viton O-ring seals and cover gasket
- Impeller - Non-clogging bronze vortex design passes 3/4" spherical solids
- 25 foot UL Listed 3 wire neoprene cord and plug. Longer cords available in lengths of 35-50 feet
- No screens to clog
- Stainless Steel screws, bolts and handle
- 1 1/2" NPT discharge with 2" or 3" flange available
- Corrosion resistant powder coated epoxy finish
- Moisture sensors available for early warning of seal failure. (Optional)
- 100% computerized tested

SELECTION GUIDE

1. Single or Double piggyback variable level float switch pump control using the 15 amp plug and receptacle. Refer to ZM1536.
2. Single piggyback variable level float switch, hard wiring the pump lead wires to the float switch leads.
3. Refer to ZM1342 and select the correct simplex control panel listed for the pump. Refer to ZM1536 and select the desired variable level control switch, 3 required.
4. Refer to ZM1342 and select the correct duplex control panel listed for the pump. Refer to ZM1536 and select the desired variable level control switch, 3 or 4 required.

Standard all models - 25 ft. cord - 1/2 H.P.

6161 MODELS	Control Selection (See Selection Guide)					Listings	
	Volts	Ph	Amps	Simplex	Duplex	UL	CSA
*N6161	115	1	15.5	2 or 3	4	Yes	Yes
*E6161	230	1	7.5	1, 2 or 3	4	Yes	Yes
I6161	200	1	8.8	2 or 3	4	No	Yes
J6161	200	3	6.4	3	4	Yes	Yes
F6161	230	3	5.2	3	4	Yes	Yes
G6161	460	3	2.9	3	4	Yes	Yes
BA6161	575	3	2.4	3	4	No	Yes

Standard all models - 25 ft. cord - 1/2 H.P.

6163 MODELS	Control Selection (See Selection Guide)					Listings	
	Volts	Ph	Amps	Simplex	Duplex	UL	CSA
*N6163	115	1	15.0	2 or 3	4	Yes	Yes
*E6163	230	1	7.5	1, 2 or 3	4	Yes	Yes
I6163	200	1	8.5	2 or 3	4	No	Yes
J6163	200	3	6.0	3	4	Yes	Yes
F6163	230	3	4.8	3	4	Yes	Yes
G6163	460	3	2.9	3	4	Yes	Yes
BA6163	575	3	2.4	3	4	No	Yes

Standard all models - 25 ft. cord - 1 H.P.

6165 MODELS	Control Selection (See Selection Guide)					Listings	
	Volts	Ph	Amps	Simplex	Duplex	UL	CSA
*E6165	230	1	10.2	1, 2 or 3	4	Yes	Yes
I6165	200	1	12.6	2 or 3	4	No	Yes
J6165	200	3	7.5	3	4	Yes	Yes
F6165	230	3	7.4	3	4	Yes	Yes
G6165	460	3	3.7	3	4	Yes	Yes
BA6165	575	3	3.0	3	4	No	Yes

* Molded Plug
** Pumps are available with optional moisture sensors. Seal Fail Indicator light available in NEMA 4X control panels.

For additional information on Zoeller products refer to catalog for; Rail Systems, ZM1347; Float Switch Brackets, ZM1328; Check Valves, ZM1348; Single Phase Controls, ZM1377; Three phase controls, ZM1342 and ZM1343; High Water Alarm Panels and Float Switches, ZM1536; Control Panels, ZM1342.

CAUTION
All installation of controls, protection devices and wiring should be done by a qualified licensed electrician. All electrical and safety codes should be followed including the most recent National Electric Code (NEC) and the Occupational Safety and Health Act (OSHA).