

Liberty Pumps®

2484-Series

Simplex Grinder Package

Factory Assembled

24" x 84"

Fiberglass Basin

2 hp Grinder Pump

1-1/4" Discharge

GR20 Guide
Rail Assembly

Features:

- Integral check valve
- Pre-mounted floats for pump control and alarm
- 4" Fiberglass hub with 4" rubber pipe seal
- Factory pre-assembled guide rail system
 - Galvanized guide rail pipe (stainless optional)
- Factory pre-assembled schedule 80 PVC discharge piping with ball valve
- Fiberglass basin with anti-flotation collar
- Structural foam cover - 1000 lb. load rating (steel optional)
 - All stainless steel supports and brackets pre-mounted
- NEMA 4X junction box for electrical connections, pre-mounted
- Stainless steel chain for pump lift-out



4" inlet
(unmounted)



SXH24=3
Control Panel with
Alarm Included



Available with
LSG or LSGX-Series
(2-Stage) Grinders



innovate. evolve.

2484-Series Specifications

Available with LSG or LSGX-Series Grinder Pumps

- 2 hp., 208-230V, 1 Phase, 60 Hz, 15 Amps, 3450 RPM
- Discharge 1 1/4"
- Cable length 25'

(See LSG200 or LSGX-Series literature for complete pump specifications. 3-Phase available. Consult factory.)

Models

LSG-Series	Discharge Hgt.	WGT
2484LSG24	24"	258 lbs.
2484LSG36	36"	258 lbs.
2484LSG48	48"	258 lbs.

LSGX-Series (2-Stage)	Discharge Hgt.	WGT
2484LSGX24	24"	264 lbs.
2484LSGX36	36"	264 lbs.
2484LSGX48	48"	264 lbs.

Discharge depth is measured from top of basin to center of discharge

Performance Curves:

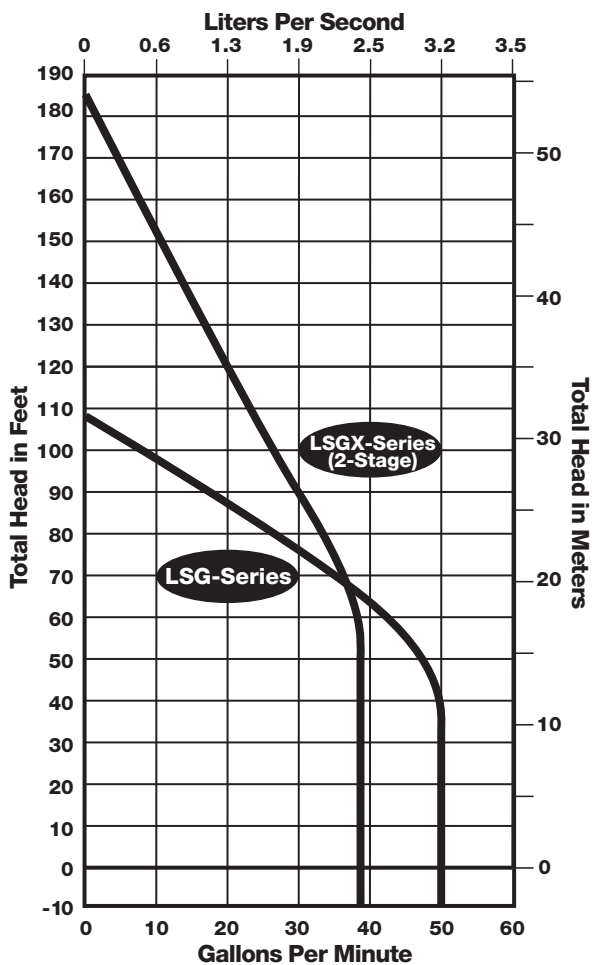

Panel Model SXH24=3 (NEMA 4x) Simplex Control & Alarm

- NEMA 4X Enclosure
- 3 Float System
- Magnetic motor contactor
- Circuit breaker
- HOA switch
- Alarm horn and beacon
- UL and cUL listed

(See SX-Series literature for complete panel specifications.)

Customized Systems:

Liberty offers many options to the base 2484 package, as well as other engineered pump systems. Consult factory for information on customized systems.

Dimensional Data:

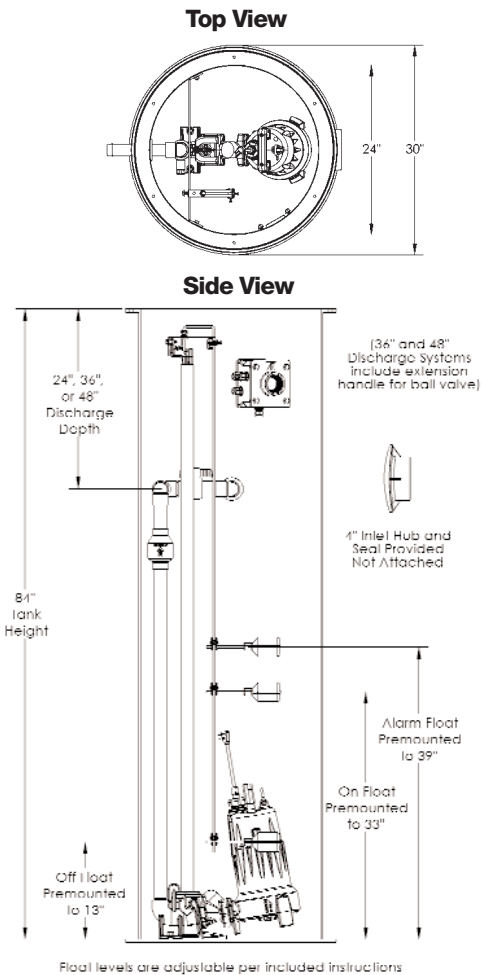

Total Capacity: 165 Gallons Capacity Per Pump Cycle: 43 Gallons Pumps Shipped Separately

Galvanized guide rails standard. For optional stainless steel rail, add "-S" to model number. Example: 2484LSG36-S
For steel cover option add "-SC" to model number. Example: 2484LSG36-SC

Specifications are subject to change without notice.

