

# Liberty Pumps®

## 2472-Series

### Simplex Grinder Package

Factory Assembled

24" x 72"

Fiberglass Basin

2 hp Grinder Pump

1-1/4" Discharge

GR20 Guide  
Rail Assembly

#### Features:

- Pre-mounted floats for pump control and alarm
- 4" Fiberglass hub with 4" rubber pipe seal
- Factory pre-assembled guide rail system
  - Integral check valve
  - Galvanized guide rail pipe (stainless optional)
- Factory pre-assembled schedule 80 PVC discharge piping with ball valve
- Fiberglass basin with anti-flotation collar
- Structural foam cover - 1000 lb. load rating (steel optional)
  - All stainless steel supports and brackets pre-mounted
  - NEMA 4X junction box for electrical connections, pre-mounted
- Stainless steel chain for pump lift-out



4" inlet  
(unmounted)



**SXH24=3**  
Control Panel with  
Alarm Included



Available with  
LSG or LSGX-Series  
(2-Stage) Grinders



innovate. evolve.

# 2472-Series Specifications

## Available with LSG or LSGX-Series Grinder Pumps

- 2 hp., 208-230V, 1 Phase, 60 Hz, 15 Amps, 3450 RPM
- Discharge 1 1/4"
- Cable length 25'

(See LSG200 or LSGX-Series literature for complete pump specifications. 3-Phase available. Consult factory.)

## Models

LSG-Series	Discharge Hgt.	WGT
2472LSG24	24"	237 lbs.
2472LSG36	36"	237 lbs.
2472LSG48	48"	237 lbs.
LSGX-Series (2-Stage)	Discharge Hgt.	WGT
2472LSGX24	24"	243 lbs.
2472LSGX36	36"	243 lbs.
2472LSGX48	48"	243 lbs.

Discharge depth is measured from top of basin to center of discharge

## Performance Curves:

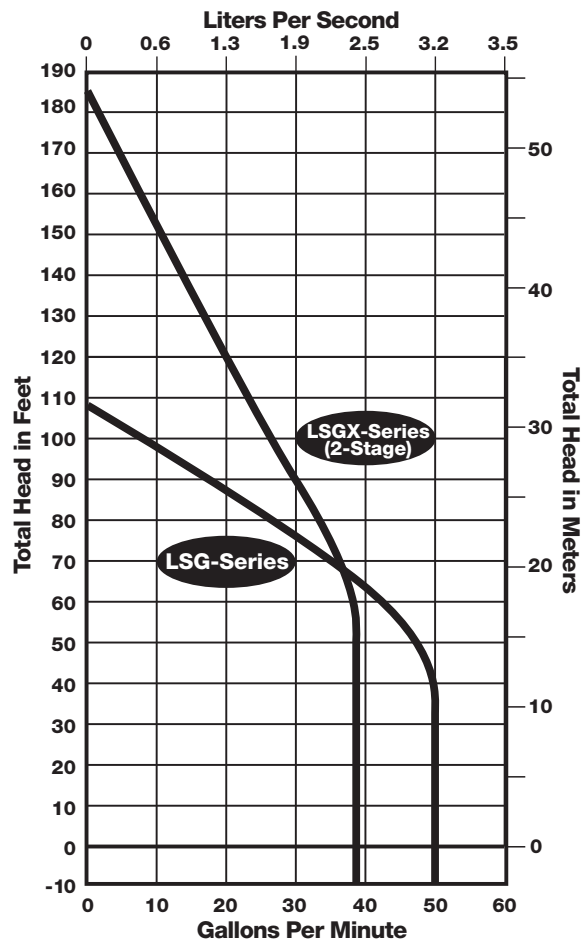

## Panel Model SXH24=3 (NEMA 4x) Simplex Control & Alarm

- NEMA 4X Enclosure
  - 3 Float System
  - Magnetic motor contactor
  - Circuit breaker
  - HOA switch
  - Alarm horn and beacon
  - UL and cUL listed
- (See SX-Series literature for complete panel specifications.)

## Customized Systems:

Liberty offers many options to the base 2472 package, as well as other engineered pump systems. Consult factory for information on customized systems.

## Dimensional Data:

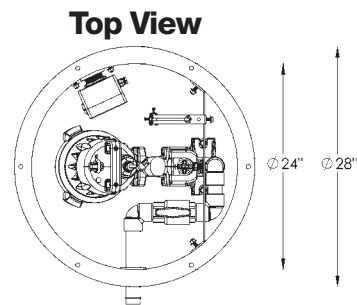

## Side View

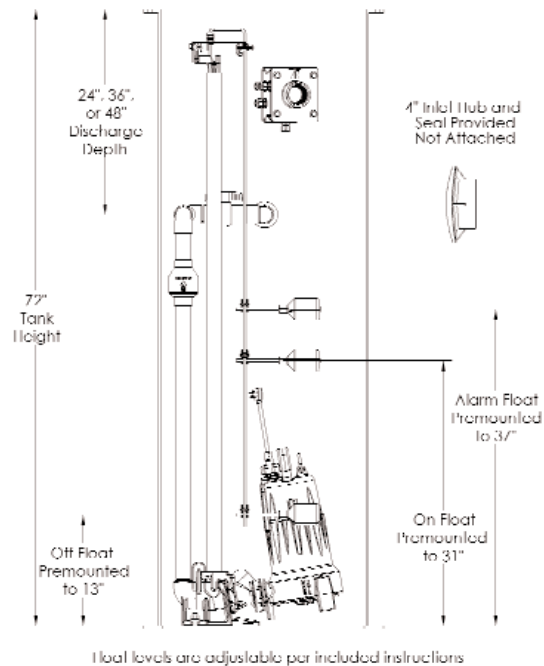

Galvanized guide rail standard. For stainless steel rail add "-S" to model number. Example: 2472LSG24-S  
For steel cover option add "-SC" to model number. Example: 2472LSG36-SC

**Total Capacity: 141 Gallons**  
**Capacity Per Pump Cycle: 39 Gallons**  
**Pump Shipped Separately**

Specifications are subject to change without notice.

