



Omnivore[®] X2

LSGX-Series

2-Stage High-head Grinder

**Unleash the power and reliability
of the Omnivore[®] – with patented
V-Slice[®] Cutter technology**

*Omnivore[®] LSGX-Series grinders
provide economical, environmentally
friendly solutions for multi-unit low
pressure sewers.*

- Lower installation cost with smaller diameter pressure pipe
- High-head capability reduces the need for costly lift stations
- Superior pump design allows for efficient pumping over a wide range of head applications – even negative head.
- Efficient design provides lower operating cost
- Unsurpassed reliability reduces maintenance and homeowner inconvenience

innovate.
evolve.

Liberty Pumps[®]



The power to build anywhere.

Omnivore® LSGX-Series 2-stage grinders provide economical answers for difficult building sites. With proven V-Slice® cutter technology, the Omnivore® macerates sanitary waste into a fine slurry allowing it to be pumped through small diameter pipe — eliminating costly gravity systems with larger pipe and deep trenching. Now, engineers, housing developers and land design planners have the freedom to replace restrictive gravity-style systems with cost-effective, Omnivore®-driven low pressure sewers.

LSGX-Series Grinder

The power to meet high-head requirements — now in a centrifugal pump design.

With literally thousands of Omnivore® grinders installed across North America, the proven design of Liberty's LSG-Series has been taken to new heights with the new 2-stage LSGX-Series. Now with twin stainless steel impellers driving flow to maximum heads of over 180 feet, the LSGX can be installed in applications where traditional progressive cavity style pumps have been required. Now get the superior cutting of patented V-Slice® technology with pumping performance that rivals traditional progressive cavity style pumps.

- Better cutting
- No rotor/stator wear
- Same pressure, more flow
- Greater reliability



Patented V-Slice® Technology

Provides in excess of 370,00 cuts per minute

Superior cutting system provides improved shredding performance over radial cutters. V-pattern provides up to 108 alternated cuts per revolution. Entire cutting system made of 440 stainless steel hardened to 58 Rc.

Recessed cutter bolt eliminates wadding

Exclusion cleanout slots and back relief clears debris from under cutter

U.S. Patent # 7,159,806

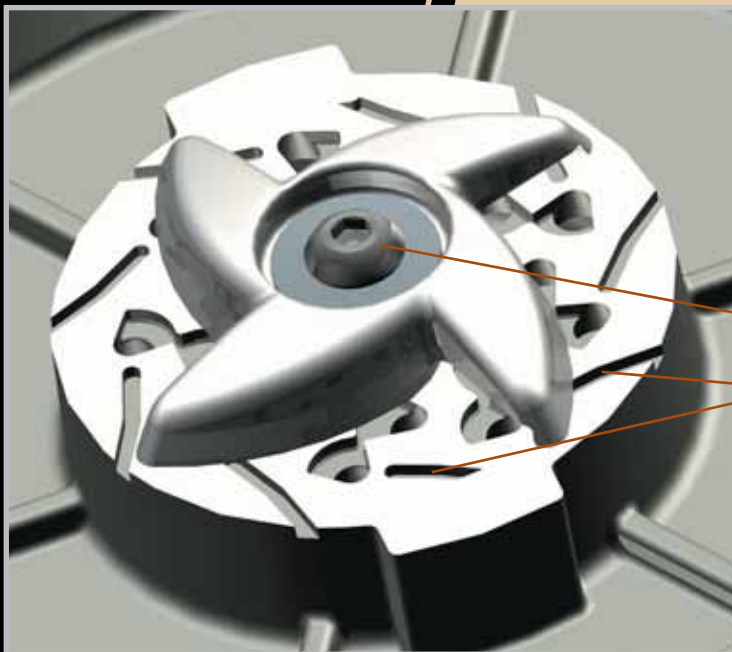

inno

Pumps

Robust performance over a wide range of heads.

The LSGX-Series curve provides superior flows over a wide range of typical pressures — necessary for multi-unit developments and “large-area” low pressure sewer systems. The 2-stage LSGX-Series now allows installation of a centrifugal design where progressive cavity style pumps have traditionally been installed.

**Omnivore® 2-stage performance curve
LSGX-Series 2 hp**

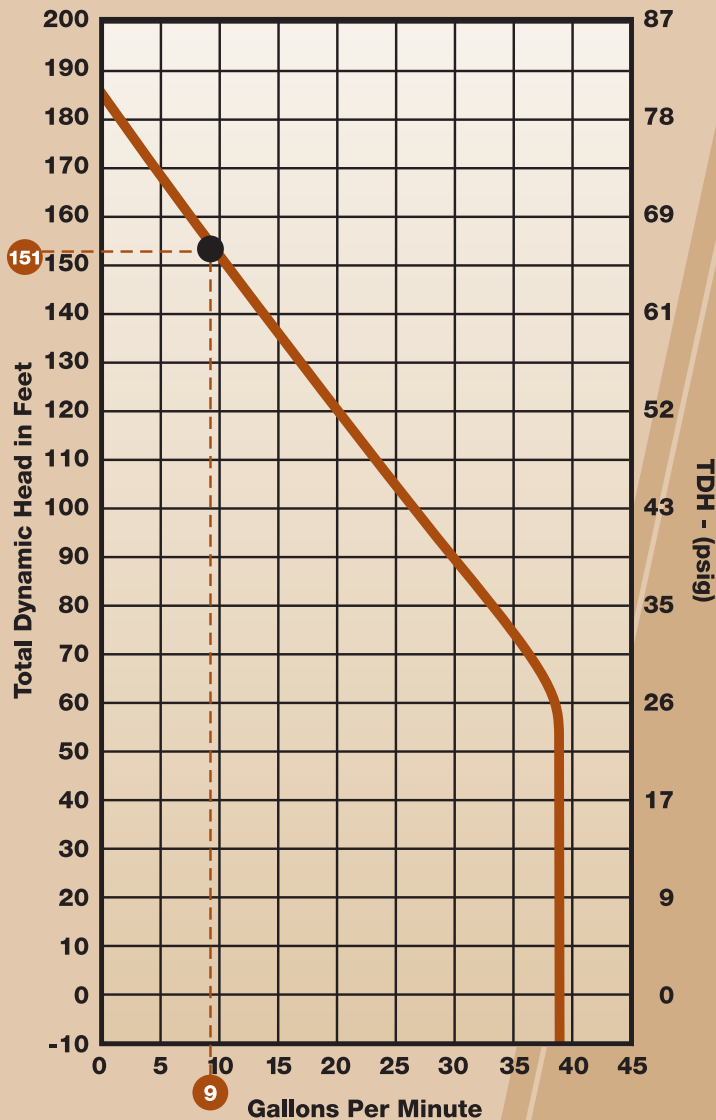

Complete Engineered Pump Systems – EPS

Liberty Pumps has the ability to design custom systems for your development project. Whether simplex or duplex, you can select from a wide array of basin sizes, discharge heights and control panel options.

Omnivore® Interchangeability

You choose — single-stage or 2-stage. Not all applications have the same hydraulic requirements. Since both LSG single-stage and LSGX 2-stage grinder pumps use the same platform and guide rail system, the right pump can be chosen for the individual application, depending on your topography. Complete interchangeability is available with the Omnivore® family of grinders. A single-stage Omnivore® can be pulled and directly replaced with a 2-stage, all within the same basin and guide rail setup — providing total flexibility.

Superior Hydraulics

Many benefits come with the use of centrifugal impellers instead of positive displacement stators. Many of the maintenance issues are eliminated, such as dry start, clogging and boot failure. Also, centrifugal impellers have the ability of flow control. When multiple units are competing for space in the same sewer main, the centrifugal design enables pumps to seek the optimum flow without accumulating pressure and causing pipe or boot failure.

vate. evolve.

Omnivore® 2-Stage LSGX-Series Specifications

Dimensional Data

DESIGN	LSGX202A				
	LSGX202M	LSGX202M-C	LSGX203M	LSGX204M	LSGX205M
Motor	Submersible	Submersible	Submersible	Submersible	Submersible
Horsepower	2	2	2	2	2
Phase	1	1	3	3	3
Voltage	208-230	208-230	208-230	440-480	575
HZ	60	60	60	60	60
R.P.M.	3450	3450	3450	3450	3450
AMPS	15	15	10.6	5.3	4.9
Lock Rotor AMPS	53	53	62	31	31
Max Fluid Temp. (Intermittent)	140 F.	140F	140 F.	140 F.	140 F.
Max Fluid Temp. (Continuous)	104 F.	104 F.	104 F.	104 F.	104 F.
Motor Insulation	Class B	Class B	Class B	Class B	Class B
Thermally Protected	Yes	Yes	No	No	No
Discharge Size	1-1/4"	1-1/4"	1-1/4"	1-1/4"	1-1/4"
Cutter Style	V-Slice®	V-Slice®	V-Slice®	V-Slice®	V-Slice®
Power Cord	12/3 SJ00W 300V	12/4 S00W 600V	14/4 SE00W 600V	14/4 SE00W 600V	14/4 SE00W 600V
Cord Length	25'	35'	25'	25'	25'
Cord Connection	Quick-Disconnect Design				
Starting circuit	Solid state	Panel	N/A	N/A	N/A
Weight	92 lbs.	97 lbs.	90 lbs.	90 lbs.	90 lbs.

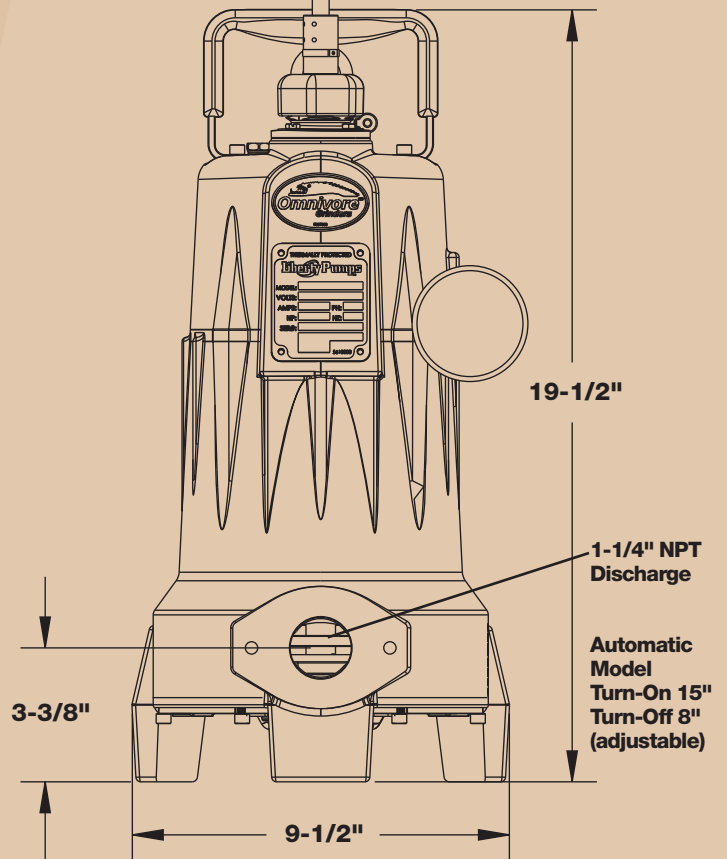

Internal start/run capacitors on single phase models except “-C” models, which have external caps and require a control panel.

Options for LSGX202M-C: External Cap Grinder

Model	Description
K001316	Start/Run Capacitor Kit (for retrofit in existing panels)
SXHC24=3	Simplex NEMA 4X Panel with start/run capacitors
AE24HC=3	Duplex NEMA 4X Panel with start/run capacitors

For complete panel specifications, see SX or AE-series literature

MATERIALS

Handle	Stainless Steel with over-mold rubber grip
Oil	ISO VG32
Motor Housing	Cast Iron Class 25
Volute Housing	Cast Iron Class 25
Rotor Shaft	400-Series Stainless Steel
Seal Upper	Silicon Carbide/Silicon Carbide
Seal Lower	*Viton Double Lip
Impeller	300 Series Stainless Steel
Cutter Plate	440 Stainless Steel hardened to Rockwell 58c
Cutter Blade	440 Stainless Steel hardened to Rockwell 58c
Upper Bearing	Single row Ball
Lower Bearing	Single row Ball (Angular Contact)
Fasteners	All 300-Series Stainless Steel
Lift-out Clasp	300-Series Stainless Steel
Exterior	Powder Coated – all cast parts

LSGX202 is available in automatic or Manual models. 3-phase models require a properly sized control panel for automatic operation.

*Viton is a registered Trade Mark of DuPont Dow Elastomers LLC.



- Optional GR20 guide Rail (sold separately)
- Cast Iron construction
- Single 1-1/4" guide rail pipe design
- Auto alignment feature (GR20 works only with LSG and LSGX-Series Pumps)
- Upper rail support bracket

www.
libertypumps
.com



Liberty Pumps • 7000 Apple Tree Avenue • Bergen, New York 14416
Phone 800-543-2550 Fax (585) 494-1839