

# Liberty Pumps®

## 1100-Series

### *Factory Pre-assembled!* **Duplex Sewage System**

*For multi-unit residential  
and commercial  
installations requiring the  
security of two pumps.*

**30" X 36" Basin  
110 Gallon Capacity**

*Factory pre-assembled with  
any of Liberty's LE-Series  
sewage pumps...you select  
the pump and control panel –  
we build the system!*

*2" or 3" discharges available*

#### **Features:**

- Heavy duty polyethylene basin;  
30" diameter x 36" high;  
110 gallon capacity
- Completely assembled system  
with piping included
  - Floats for control unit  
factory pre-set\*
  - 4" fiberglass inlet hub with  
rubber pipe seal
- Heavy, 1/4" enamel coated steel cover  
with separate pump access covers  
and a 10" diameter inspection cover  
(Fiberglass cover assembly available)
- Pump restraints (torque-stops) hold  
pumps securely in proper position



**\*NOTE:** 1100-Series systems require a separately ordered control panel for automatic operation and alternation of pumps. Floats are included as part of the control panel and are pre-mounted in system when the control is ordered with the base 1100-Series unit. See AE-series literature or consult factory for proper control selection.

innovate. evolve.

# 1100-SERIES DUPLEX SEWAGE SYSTEM

## TECHNICAL SPECIFICATIONS

### SYSTEM

The duplex sewage system shall be model \_\_\_\_\_ / \_\_\_\_\_ as manufactured by Liberty Pumps, or equal. The system shall be factory pre-assembled with the pumps, discharge pipe nipples and floats pre-mounted in the basin. Volume per pump cycle shall be factory set at 28 U.S. gallons. Floats shall be tethered to a removable stand pipe/access cover assembly.

### BASIN

The basin shall be constructed of rotationally molded polyethylene and shall have a total capacity of 110 U.S. gallons. Internal dimensions shall be 30" diameter X 36" deep. The basin shall be provided with a 4" inlet hub and molded "torque-stops" to secure pumps in proper position.

### COVER

The primary cover shall be "heavy-duty" 1/4" plate steel, enamel-coated on both sides. The cover shall be 34" in diameter and have \_\_\_\_\_ (2" or 3") discharges and vent flange. The cover shall be fitted with two 16" diameter pump access openings and one 10" inspection cover with integral stand pipe for float tethering. The cover assembly shall be provided with all necessary bolts and gaskets for mounting to basin.

### PUMPS

See individual LE-Series literature sheet for specifications on the pumps selected.

### Dimensional Data:

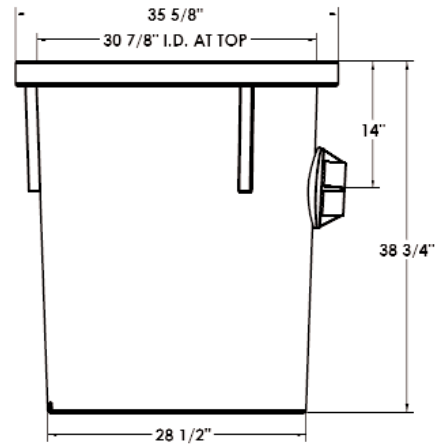
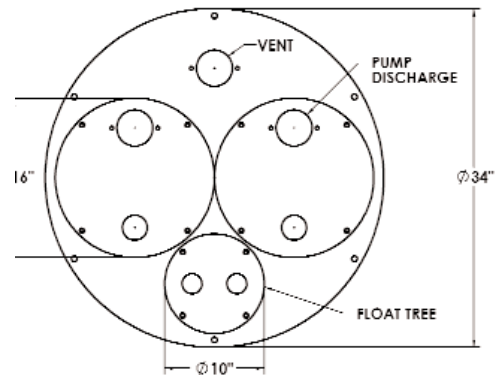

### 2" Discharge Models

MODEL NUMBER	HP	PUMP VOLTAGE	PHASE	WEIGHT IN LBS.
1102/LE41M	4/10	115	1	210
1102/LE51M	1/2	115	1	217
1102/LE52M	1/2	208-230	1	218
1102/LE71M	3/4	115	1	255
1102/LE72M	3/4	208-230	1	255
1102/LE73M	3/4	208-230	3	260
1102/LE74M	3/4	440-480	3	260
1102/LE102M	1	208-230	1	261
1102/LE103M	1	208-230	3	265
1102/LE104M	1	440-480	3	265
1102/LE105M	1	575-600	3	265
1102/LEH102M	1	208-230	1	261
1102/LEH103M	1	208-230	3	265
1102/LEH104M	1	440-480	3	265
1102/LEH105M	1	575	3	265
1102/LEH152M	1.5	208-230	1	319
1102/LEH153M	1.5	208-230	3	319
1102/LEH154M	1.5	440-480	3	319
1102/LEH155M	1.5	575	3	319
1102/LEH202M	2	208-230	1	325
1102/LEH203M	2	208-230	3	325
1102/LEH204M	2	440-480	3	325
1102/LEH205M	2	575	3	325

**IMPORTANT: Control panel must be ordered separately.**

AE-Series panels must be matched to the amperage of the pumps selected. See AE-Series literature or consult factory for proper selection. **800-543-2550**

**For 3" discharge models, change the model prefix to 1103/... Example: 1103/LE51M (add 12 lbs. to wgt.)**

**Individual part numbers for basins & covers**

Part #	Description
K001202	30" x 36" basin, with inlet hub
K001200	Cover, 2" discharge & vent with blank inspection cover
K001201	Cover, 3" discharge & vent with blank inspection cover
K001203	10" inspection cover with float tree for 3-float control (floats not included)



Specifications are subject to change without notice.