

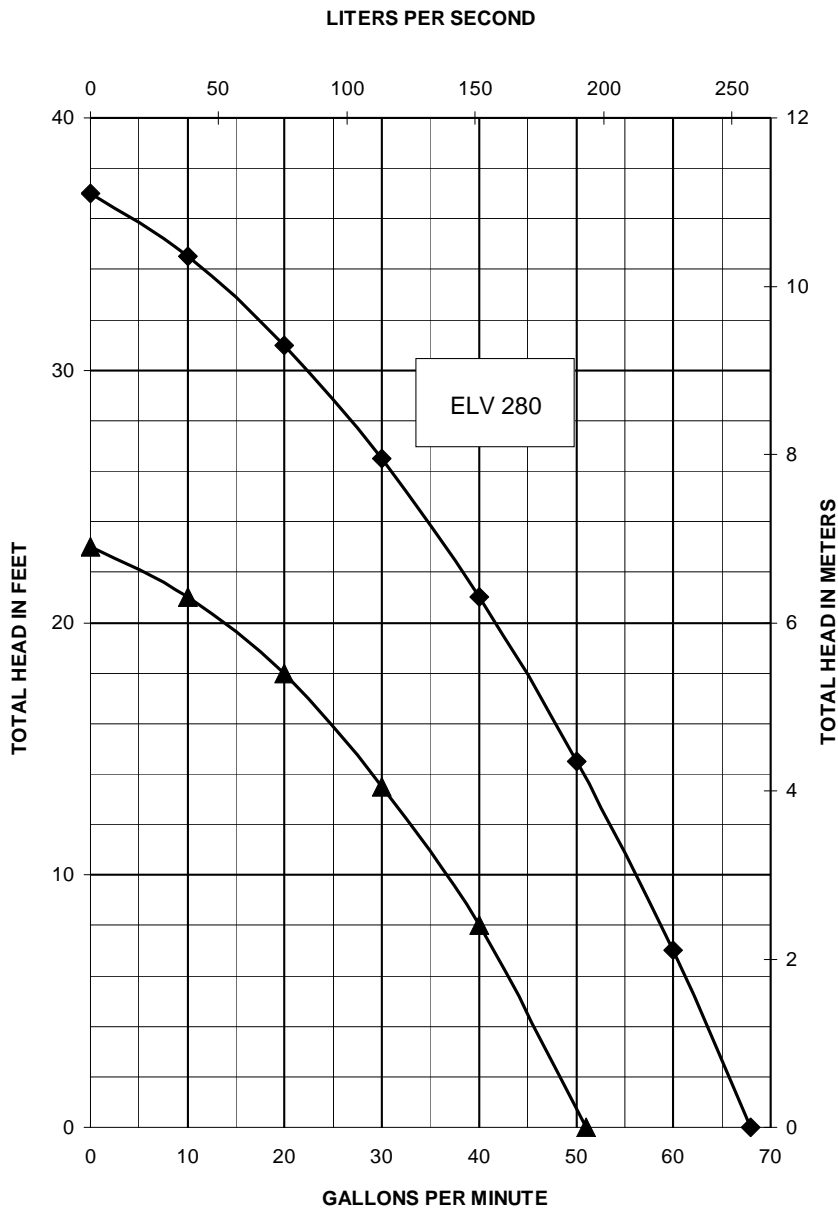

## Pump Specifications

### ELV250 1/3 hp and ELV280 1/2 hp Submersible Sump Pump with OilTector Control

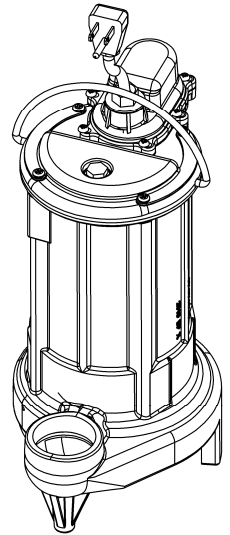

# ELV280 Dimensional Data

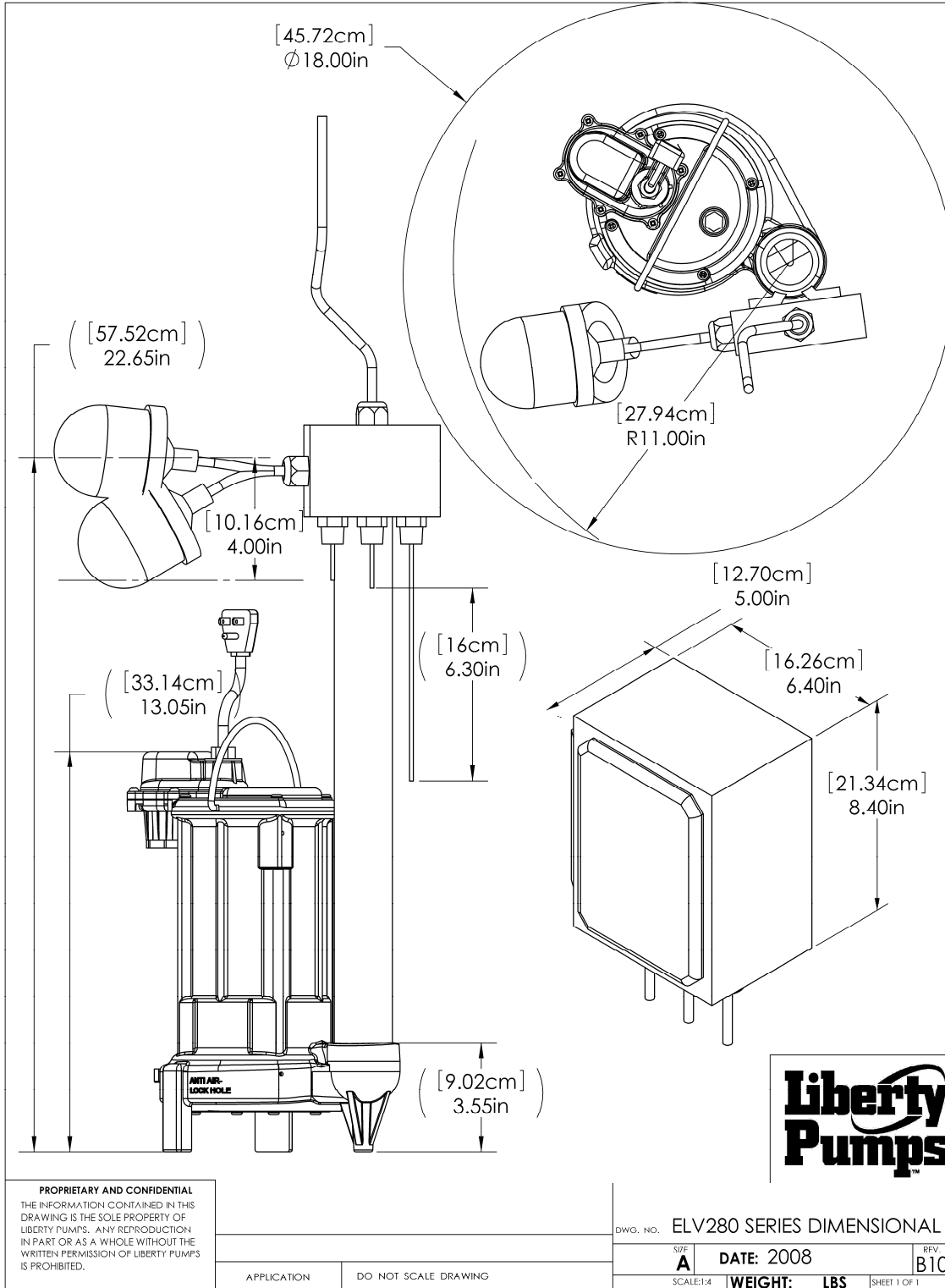

# ELV250 Dimensional Data

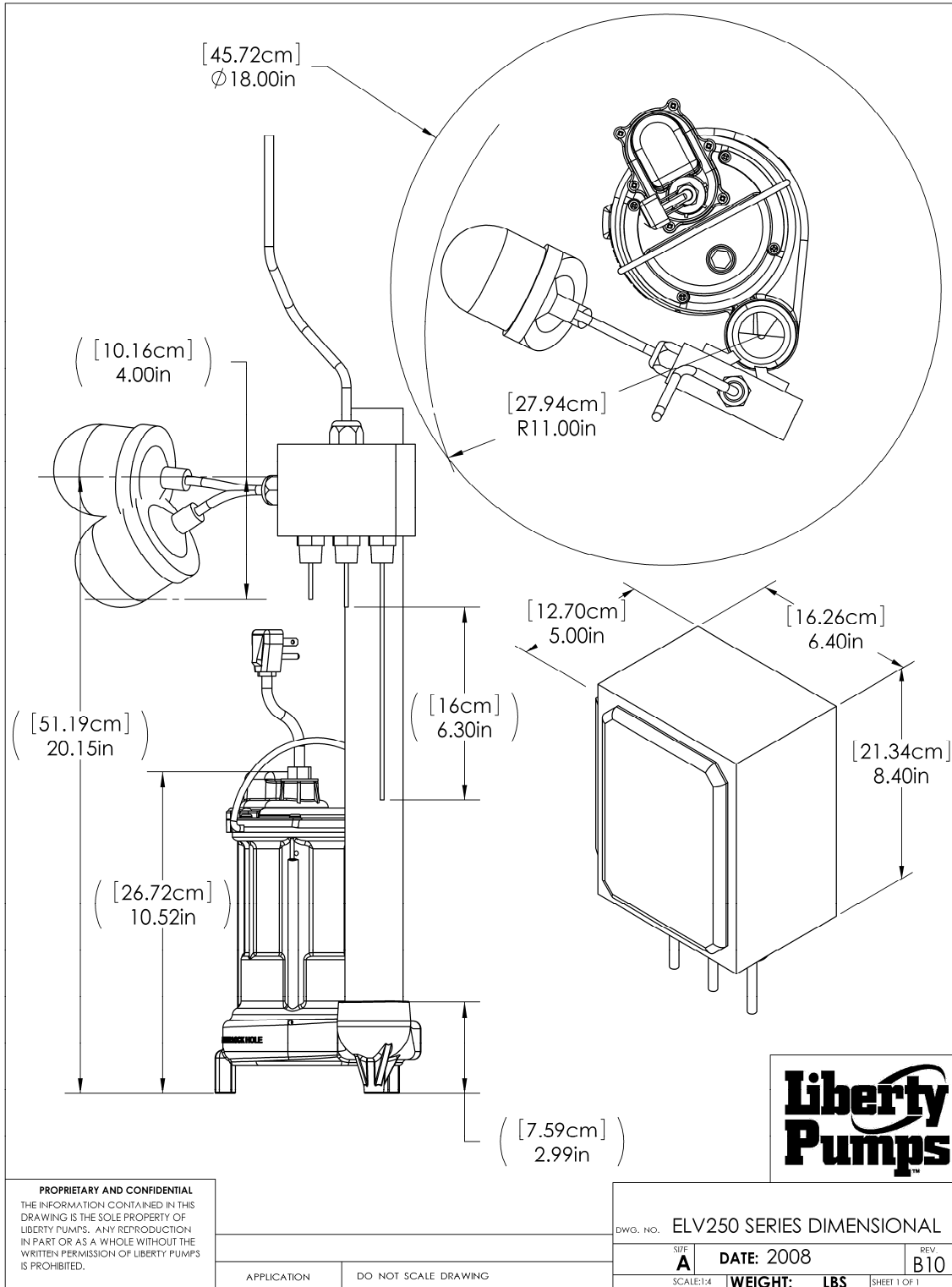

## ELV-Series Electrical Data

---

MODEL	HP	VOLTAGE	PHASE	FULL LOAD AMPS	LOCKED ROTOR AMPS	THERMAL OVERLOAD TEMP	STATOR WINDING CLASS	CORD LENGTH FT	DISCHARGE	AUTOMATIC
ELV280	1/2	115	1	8.5	23	120°C/ 248°F	B	25	1 1/2	YES W/ CONTROL
ELV280HV	1/2	208-230	1	4.6	12.5	120°C/ 248°F	B	25	1 1/2	YES W/ CONTROL
ELV250	1/3	115	1	5.2	8	120°C / 248°F	B	25	1 1/2	YES W/ CONTROL

## ELV-Series Technical Data

---

<b>IMPELLER</b>	VORTEX ENGINEERED POLYMER
<b>SOLIDS HANDLING SIZE</b>	
ELV250	1/2"
ELV280 & ELV280HV	3/4"
<b>PAINT</b>	POWDER COAT
<b>MAX LIQUID TEMP</b>	60°C/ 140°F
<b>MAX STATOR TEMP</b>	CLASS B 130°C/ 266°F
<b>THERMAL OVERLOAD</b>	120°C/ 248°F
<b>POWER CORD TYPE</b>	SJE00W
<b>MOTOR HOUSING/ VOLUTE</b>	CLASS 25 CAST IRON
<b>SHAFT</b>	STAINLESS
<b>HARDWARE</b>	STAINLESS
<b>ORINGS</b>	BUNA N
<b>SEAL</b>	
ELV250	ENGINEERED DOUBLE LIP WITH STAINLESS STEEL SPRINGS
ELV280 & ELV280HV	UNITIZED CERAMIC CARBON
<b>WEIGHT</b>	
ELV250	23 LBS
ELV280 & ELV280HV	30 LBS
<b>MIN. SUMP SIZE</b>	Ø18" X 30"

# ELV-Series Specifications

---

## 1.01 GENERAL:

The contractor shall provide labor, material, equipment, and incidentals required to provide \_\_\_\_\_(QTY) centrifugal pumps as specified herein. The pump models covered in this specification are ELV Series single phase pumps. The pump furnished for this application shall be model \_\_\_\_\_ as manufactured by Liberty pumps.

## 2.01 OPERATING CONDITIONS:

Each submersible pump shall be rated for \_\_\_\_hp, \_\_\_\_\_volts, single phase, 60 Hz., & 3450 RPM. The unit shall produce \_\_\_\_\_G.P.M. at \_\_\_\_\_ feet of total dynamic head.

The submersible pump shall be capable of handling water with \_\_\_\_\_ solid handling capability. The submersible pump shall have a shut-off head of \_\_\_\_\_ feet and a maximum flow of \_\_\_\_\_ GPM @ 5 feet of total dynamic head.

The pump shall be controlled with:

The manual pump is connected to a control which has the ability to prevent oil from being pumped from the vault. This same control unit will activate an alarm when an oil "film" is detected or when a high water condition exists. The system will continue to monitor and remove water from the vault even if an oil condition is detected.

## 3.01 CONSTRUCTION:



Each centrifugal sump pump shall be equal to the c<sup>us</sup> Certified ELV-Series pumps as manufactured by Liberty Pumps, Bergen NY. The castings shall be constructed of class 25 cast iron. The motor housing shall be oil filled to dissipate heat. Air filled motors shall not be considered equal since they do not properly dissipate heat from the motor. All mating parts shall be machined and sealed with a Buna-N o-ring. All fasteners exposed to the liquid shall be stainless steel. The motor shall be protected on the top side with sealed cord entry plate with molded pins to conduct electricity eliminating the ability of water to enter internally through the cord. The motor shall be protected on the lower side with a unitized ceramic/carbon seal with stainless steel housings and spring or engineered double lip seal with stainless steel springs. The pump shall be furnished with stainless steel handle.

## 4.01 ELECTRICAL POWER CORD

The submersible pump shall be supplied with a 25 feet of multiconductor power cord. It shall be cord type YELLOW UL 16-3 SJEOOW 300V 105°C, capable of continued exposure to the pumped liquid. The power cord shall be sized for the rated full load amps of the pump in accordance with the National Electric Code. The power cable shall not enter the motor housing directly but will conduct electricity to the motor by means of a water tight compression fitting cord plate assembly, with molded pins to conduct electricity. This will eliminate the ability of water to enter internally through the cord, by means of a damaged or wicking cord.

## 5.01 MOTORS

Single phase motors shall be oil filled, permanent split capacitor, class B insulated NEMA B design, rated for continuous duty. At maximum load the winding temperature shall not exceed 130 degrees C unsubsmerged. Since air filled motors are not capable of dissipating heat they shall not be considered equal. The pump motor shall have an integral thermal overload switch in the windings for protecting the motor. The capacitor circuit shall be mounted internally in the pump.

## **6.01 BEARINGS AND SHAFT**

An upper sleeve and lower ball bearing shall be required. The lower ball bearing shall be a single ball / race type bearing. Both bearings shall be permanently lubricated by the oil, which fills the motor housing. The motor shaft shall be made of 300 or 400 series stainless steel and have a minimum diameter of .311"

## **7.01 SEALS**

The pump shall have a unitized carbon / ceramic seal with stainless steel housings and spring equal to Crane Type 6A or engineered double lip seal with stainless steel springs. The motor plate / housing interface shall be sealed with a Buna-N o-ring.

## **8.01 IMPELLER**

The impeller shall be vortex style made of an engineered polymer, with pump out vanes on the back shroud to keep debris away from the seal area. It shall be threaded to the motor shaft.

## **9.01 CONTROLS**

The control unit has three probes and a float ball switch. The pump will activate when the middle probe contacts water, and will remain on until the first, longest probe no longer is in contact with water. A high water alarm is activated when third or shortest probe contacts water. The system will ignore a small film of oil, however larger volumes of oil will be detected when the alarm probe does not detect water and the float ball activates. The system will continue to operate, removing water not oil from the vault even when oil has been detected.

## **10.01 PAINT**

The exterior of the casting shall be protected with powder coat paint.

## **11.01 SUPPORT**

The pump shall have cast iron support legs, enabling it to be a free standing unit. The legs will be high enough to allow 3/4" solids to enter the volute.

## **12.01 SERVICEABILITY**

Components required for the repair of the pump shall be shipped within a period of 24 hours.

## **13.01 TESTING**

The pump shall have a ground continuity check and the motor chamber shall be Hi-potted to test for electrical integrity, moisture content and insulation defects. The motor and volute housing shall be pressurized, and an air leak decay test is performed to ensure integrity of the motor housing. The pump shall be run, voltage current monitored, and the tester checks for noise or other malfunction.

## **14.01 QUALITY CONTROL**

The pump shall be manufactured in an ISO 9001 certified Facility.

## **15.01 WARRANTY**

Standard limited warranty shall be 2 years.