



Submittal Data Information

VT Series Pumps

301-1800

EFFECTIVE: JANUARY 15, 2009

SUPERSEDES: DECEMBER 1, 2008

JOB _____ ENGINEER _____ CONTRACTOR _____ REP. _____

ITEM NO.	MODEL NO.	IMPELLER DIA.	G.P.M.	HEAD/FT.	SUMP DEPTH.	TPL

WEIGHT _____ PUMP/MOTOR _____

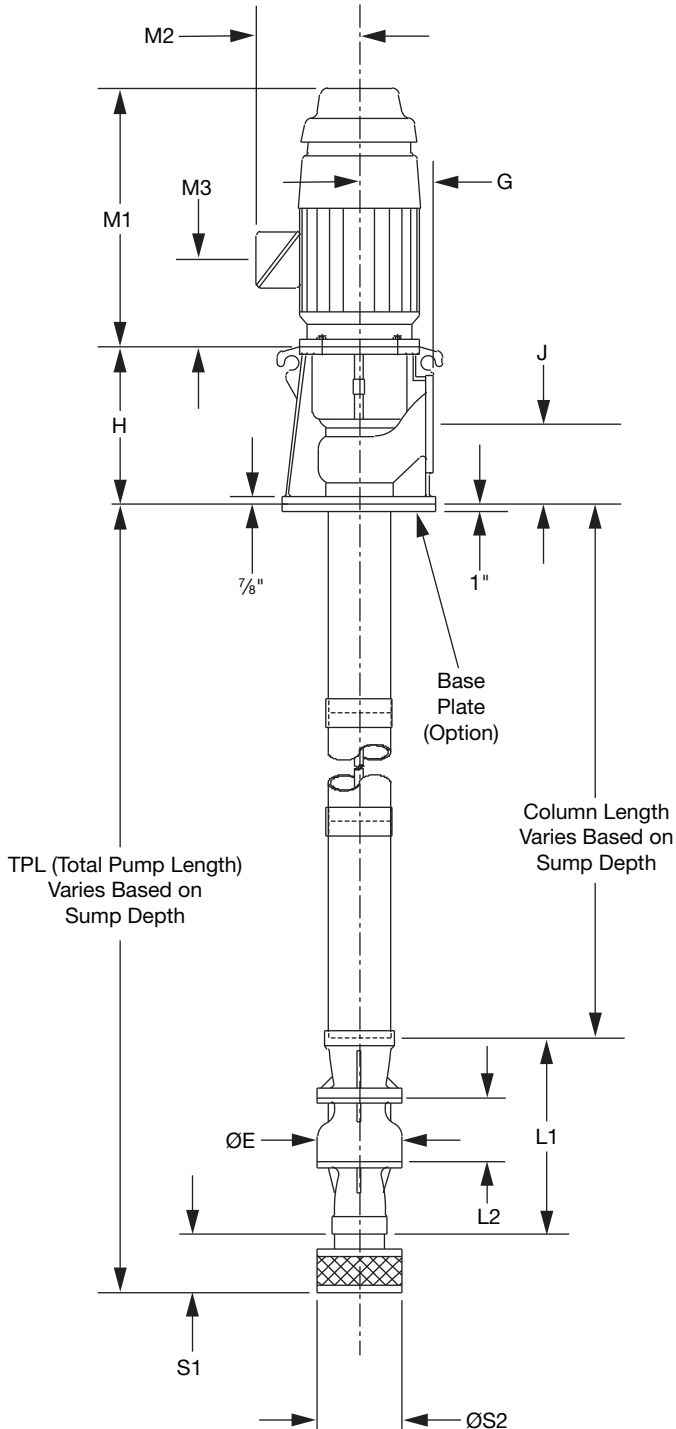

BOWL MODEL # _____

IMP. DIA. _____

IMP. TYPE _____

SPECIAL _____

BASKET STRAINER _____

COLUMN ASSY _____

DISCHARGE HEAD _____

DISCHARGE FLANGE _____

BASE PLATE _____

SEAL TYPE _____

OTHER _____

MOTOR

MAKE _____

ENCLOSURE _____

N.R.R. _____

H.P. _____ S.F. _____

R.P.M. _____

PHASE _____ CYCLE _____

VOLTAGE _____

V.H.S. _____

OTHER MOTOR INFO _____

BOWL ASSEMBLY

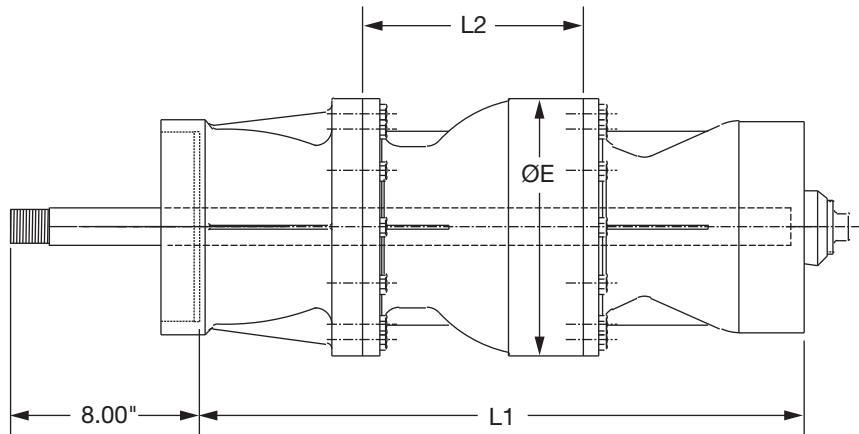

BOWL ASSEMBLY DIMENSIONS:

All dimensions are in inches. All weights are in pounds.

MODEL AND SIZE	SINGLE STAGE ASSY. LENGTH	BOWL LENGTH	STANDARD BOWL O.D.	BOWL SHAFT DIAMETER	COLUMN PIPE SIZES	SUCTION PIPE SIZES	1st STAGE BOWL ASSY. WGT.	ADDITIONAL STAGE WGT.
	L1	L2	ØE					
VT06LL/VT06LH	12.688	5.125	6.281	1.000	4	4	50	17
VT06HL/VT06HH	12.875	4.750	5.563	1.000	4	4	40	12
VT07LL/VT07LH	16.344	5.500	7.094	1.188	4, 6	6	70	25
VT07ML/VT07MH	17.219	6.375	7.094	1.188	4, 6	6	73	28
VT07HL/VT07HH	17.938	7.094	7.094	1.188	4, 6	6	74	29
VT08HL	23.500	7.875	8.188	1.188	6	6	106	39
VT08HH	23.500	7.875	8.188	1.188	6	6	106	39
VT09CC	23.000	7.750	9.500	1.500	6	6	150	60
VT09EC	23.000	7.750	9.500	1.500	6	6	150	60
VT09ML	23.500	8.500	9.500	1.500	6	6	159	64
	20.125				8		143	
VT09MH	23.500	8.500	9.500	1.500	6	6	159	64
	20.125				8		143	
VT09HL	24.562	9.313	9.500	1.500	6	6	156.4	68
	20.500				8		141.8	
VT09HH	24.532	9.313	9.500	1.500	6	6	156.4	68
	20.500				8		141.8	
VT09ZC	23.000	8.500	9.500	1.500	8	8	145	54
VT12CC	26.500	9.000	11.625	1.688	6, 8	8	235	105
VT12DC	26.500	9.000	11.625	1.688	6, 8	8	235	105
VT12IC	27.500	10.000	11.750	1.688	6, 8	8	250	107
VT12KC	27.500	10.000	11.750	1.688	6, 8	8	250	107
VT12MC	29.125	9.312	11.687	1.688	8, 10	10	274	104
VT12HH	28.250	11.250	11.750	1.688	8	10	251	99
					10		253	
VT14ML	33.750	13.500	14.000	2.188	10, 12	10	377	159
VT14MH	33.750	13.500	14.000	2.188	10, 12	10	377	159
VT14HH	33.875	13.625	14.000	2.188	10, 12	10	377	159
VT16MH	31.625	15.000	15.500	1.938	12	BELL	569	237
VT16HH	32.250	15.625	16.050	1.938	12	BELL	583	255

DISCHARGE HEAD

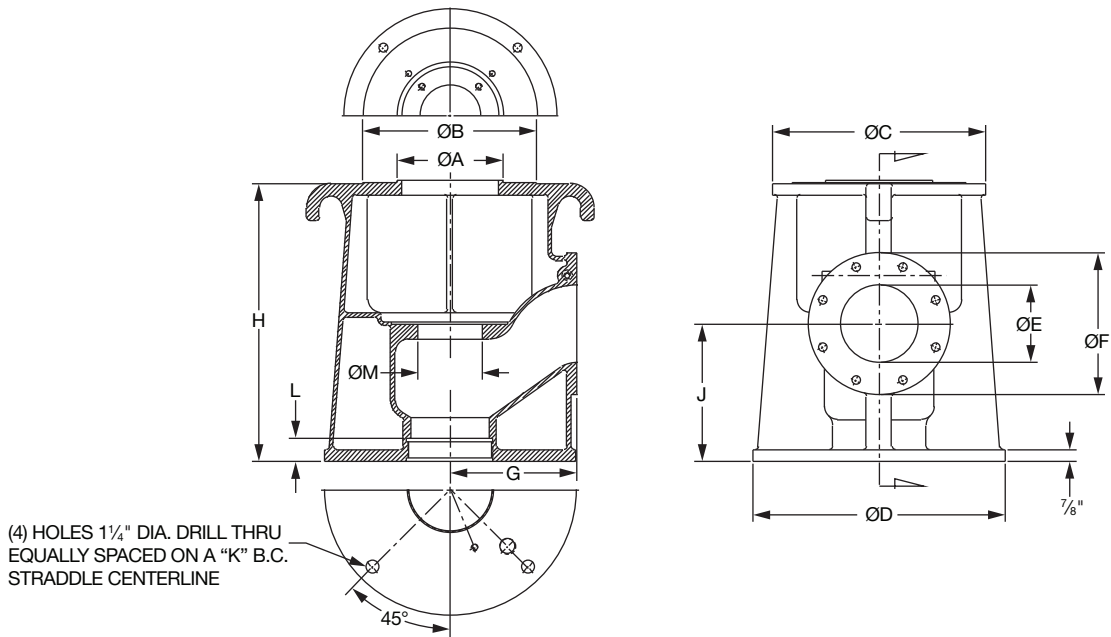

DISCHARGE HEAD DIMENSIONS:

All dimensions are in inches. All weights are in pounds.

MODEL/SIZE	ØA	ØB	ØC	ØD	ØE	ØF	G	H	J	K	L	ØM	WGT.
VT04DH	8 1/4	N/A	12	19 3/8	4	9	9 7/8	21 1/2	10 5/8	17	1 3/4	4.687	186
VT06DH	8 1/4	13 1/2	16 1/2	19 1/2	6	11	9 7/8	21 1/2	10 5/8	17	1 3/4	4.687	262
VT08DH	8 1/4	13 1/2	16 1/2	21 1/4	8	13 1/2	9 7/8	21 1/2	10 5/8	18 3/4	2	4.687	279
VT10DH	N/A	13 1/2	20	21 1/4	10	16	9 7/8	21 1/2	10 5/8	18 3/4	2 1/2	4.687	311
VT12DH	N/A	13 1/2	20	24 7/8	12	19	14	23	12	22 3/4	2 1/2	5.5625	630

BASE PLATE

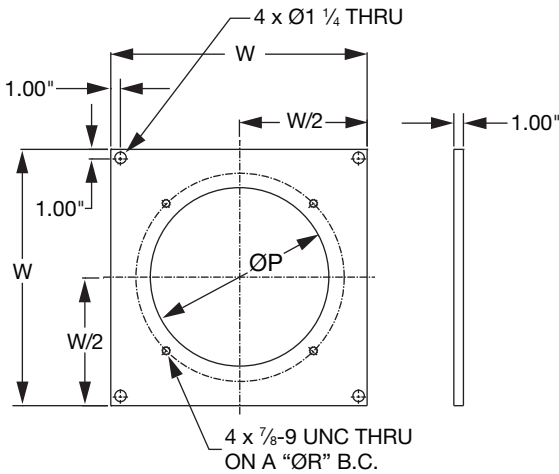

BASE PLATE DIMENSIONS:

All dimensions are in inches. All weights are in pounds.

MODEL/ SIZE	DISCHARGE HEAD SIZE	W	W/2	ØP	ØR (BOLT CIRCLE)	WGT.
VT04BP	4"	24"	12"	14"	17.000"	104
VT06BP	6"	24"	12"	14"	17.000"	104
VT08BP	8"	24"	12"	16"	18.750"	104
VT10BP	10"	24"	12"	16"	18.750"	104
VT12BP	12"	28"	14"	19.5"	22.750"	165

BASKET TYPE SUCTION STRAINER

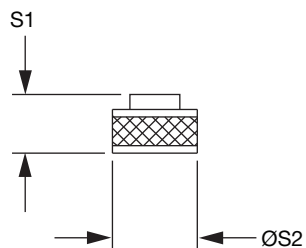

SUCTION STRAINER DIMENSIONS:

MODEL/ SIZE	SUCTION SIZE	S1	ØS2	WEIGHT
VT04BS	4	6	6 1/2	8
VT06BS	6	6	8 1/2	9
VT08BS	8	7 3/4	10 3/4	13
VT10BS	10	9 7/8	13	17
VT12BS	12	11 7/8	18 5/8	25

All dimensions are in inches. All weights are in pounds.

COLUMN ASSEMBLIES

COLUMN ASSEMBLIES DIMENSIONS:

ITEM NUMBER	DESCRIPTION	SHAFT LENGTH (FEET)	SHAFT DIAMETER (INCHES)	MAX HORSEPOWER	WEIGHT (LBS)		
VT04100CA-T05	4 x 1 Standard Wall	5	1	40	75		
VT04100CA-T10		10			150		
VT06100CA-T05	6 x 1 Standard Wall	5			120		
VT06100CA-T10		10			230		
VT06118CA-T05	6 x 1 ³ / ₁₆ Standard Wall	5			1 ³ / ₁₆	75	125
VT06118CA-T10		10					240
VT08118CA-T05	8 x 1 ³ / ₁₆ Standard Wall	5	155				
VT08118CA-T10		10	310				
VT10118CA-T05	10 x 1 ³ / ₁₆ Standard Wall	5	200				
VT10118CA-T10		10	400				
VT12118CA-T05	12 x 1 ³ / ₁₆ Standard Wall	5	270				
VT12118CA-T10		10	540				
VT08150CA-T05	8 x 1 ¹ / ₂ Standard Wall	5	1 ¹ / ₂	150			170
VT08150CA-T10		10					330
VT10150CA-T05	10 x 1 ¹ / ₂ Standard Wall	5					215
VT10150CA-T10		10					420
VT12150CA-T05	12 x 1 ¹ / ₂ Standard Wall	5			285		
VT12150CA-T10		10			560		
VT10168CA-T05	10 x 1 ¹¹ / ₁₆ Standard Wall	5			1 ¹¹ / ₁₆	300	225
VT10168CA-T10		10					440
VT12168CA-T05	12 x 1 ¹¹ / ₁₆ Standard Wall	5					295
VT12168CA-T10		10					580

Column assemblies cut to length.

MOTOR

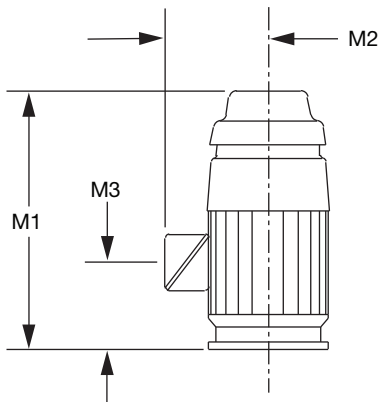

NEMA MG1-31 Design
High Efficiency Vertical Hollowshaft WP-1 Enclosure

GE VHS MOTOR DIMENSIONS:

HP (1760RPM)	M1	M2	M3	WEIGHT
5	24.29	9.30	8.14	220
7.5	24.29	9.30	8.14	220
10	24.29	9.30	8.14	220
15	30.60	10.97	9.41	340
20	27.85	10.97	9.41	370
25	29.25	14.60	10.19	507
30	29.25	14.60	10.19	507
40	32.53	14.68	13.40	760
50	32.53	14.68	13.40	760
60	35.70	15.78	16.12	1102
75	35.70	15.78	16.12	1102
100	41.96	20.90	15.68	1590

All dimensions are in inches. All weights are in pounds.

PUMP MATERIALS OF CONSTRUCTION:

ITEM	STANDARD PUMP CONSTRUCTION	OPTIONAL
Bowl Assembly	Cast Iron, ASTM A48, Class 30	CF
Impeller	304SS, ASTM A296	CF
Pump Shaft	416SS, ASTM A582	CF
Discharge Head	Ductile Iron, ASTM A536, Class 65	CF
Packing/ Mechanical Seal	John Crane 1345 Packing	Tungsten/Viton Balanced Seal
Column Pipe	Steel Pipe, ASTM A53 Grade B	CF
Bearing Retainers	Stainless Steel, AISI 201	CF
Lineshaft	416SS, ASTM A582	CF

ACCESSORIES MATERIALS OF CONSTRUCTION:

ITEM	STANDARD CONSTRUCTION	OPTIONAL
Suction Strainer	304SS, ASTM A240	CF
Baseplate	A-36 HRS Steel	CF
Shaft Guard	304SS, ASTM A240	CF

OPERATING SPECIFICATIONS:

Flange	ANSI 150 lb.
Working Pressure	200 PSIG (1379 kpa)
Temperature	140°F (60°C)

Do it Once. Do it Right.®

TACO, INC., 1160 Cranston Street, Cranston, RI 02920 Telephone: (401) 942-8000 FAX: (401) 942-2360.
TACO (Canada), Ltd., 8450 Lawson Road, Unit #3, Milton, ON L9T 0J8. Telephone: 905/564-9422. FAX: 905/564-9436.

Visit our web site at: <http://www.taco-hvac.com>

Printed in USA
 Copyright 2009
 TACO, Inc.