

## PACKAGED SEWAGE SYSTEMS

### SRM-BP

The Myers® SRM-BP BasinPro™ Packaged Sewage System is an ideal choice for new construction or retrofit. Installer-friendly features include a 360° Top Grip for easy installation. The E-Z Switch™ Rod lets you easily remove the float switch without affecting the basin lid, pump or plumbing. Available with a 4/10 HP high endurance motor, with 2" solids-handling capacity. Passive radon protection provided by gas-tight seal between structural foam lid and basin.

#### APPLICATIONS

Sewage, high-capacity sump, effluent

#### SPECIFICATIONS

- Capacities – 95 GPM (360 LPM)
- Shut-off Head – 19' (5.8 m)
- Solids Handling – 2" (50.8 mm)
- Liquids Handling – Septic effluent and sewage
- Intermittent Liquid Temperature – Up to 140°F (60°C)
- Motor/Electrical Data – 4/10 HP, PSC, 115V, 12A, 1Ø, 60Hz
- Acceptable pH Range – 5-9
- Discharge, NPT – 2" (50.8 mm)
- Housing – Heavy cast iron
- Power Cord – 20', 16/3, SJTW
- Impeller – Recessed, thermoplastic
- Volute Case – Cast iron
- Shaft Seal – Type 11A, carbon and ceramic
- Basin Size – 24" x 24" structural foam construction



Pump only

#### FEATURES

##### Fully Assembled

Pump is pre-installed in basin, with integral torque stops to ensure stability

##### Oil-filled Motor

For maximum heat dissipation and continuous bearing lubrication

##### Recessed Vortex Impeller

For free flow of liquids, solids up to 2" diameter

##### Anti-floatation Features

Include concrete splash lip and unique basin shape to keep the system from floating or becoming "un-installed"

##### Integral 360° Top Grip

For easy lifting and handling in tight spaces

##### Stackable Design

Allows for compact inventory.

##### E-Z Switch™ Rod

Allows removal of float switch without disassembling basin lid, or handling pump or plumbing. Additional clip for secondary float included; float sold separately.

##### Available With Alarm, Optional

#### ORDERING INFORMATION

Catalog Number	HP	Volts	Phase/Cycles	Amps	Discharge Size	Switch Type	Cord Length	Approx. Wt. Lbs.
SRM-BP	4/10	115	1/60	12.0	2"	Tethered Automatic	20'	50
SRM-BP-SA1*	4/10	115	1/60	12.0	2"	Tethered Automatic	20'	60

\*Includes SA-1 alarm.

In order to provide the best products possible, specifications are subject to change. BasinPro® and Myers® are registered trademarks of Pentair Water. E-Z Switch™ is a trademark of Pentair Water.



**Myers**<sup>®</sup>

Pentair Water

**PACKAGED SEWAGE SYSTEMS**

**DIMENSIONS**

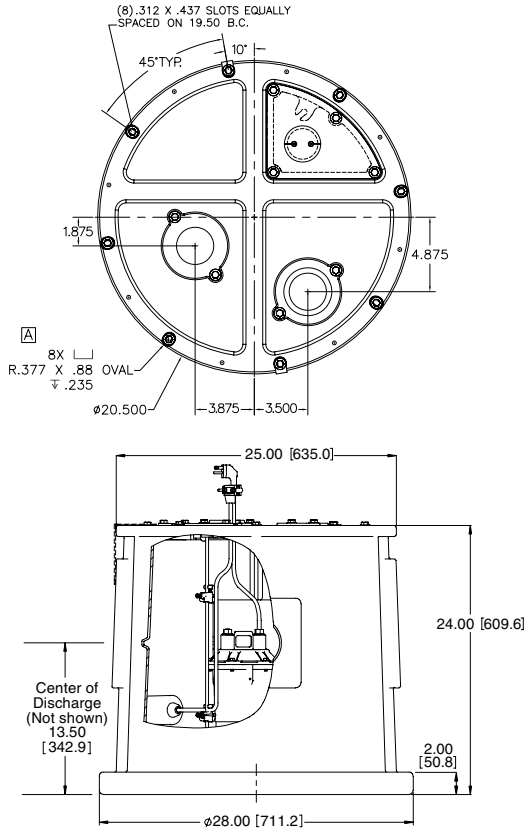

**SECTIONAL VIEW**

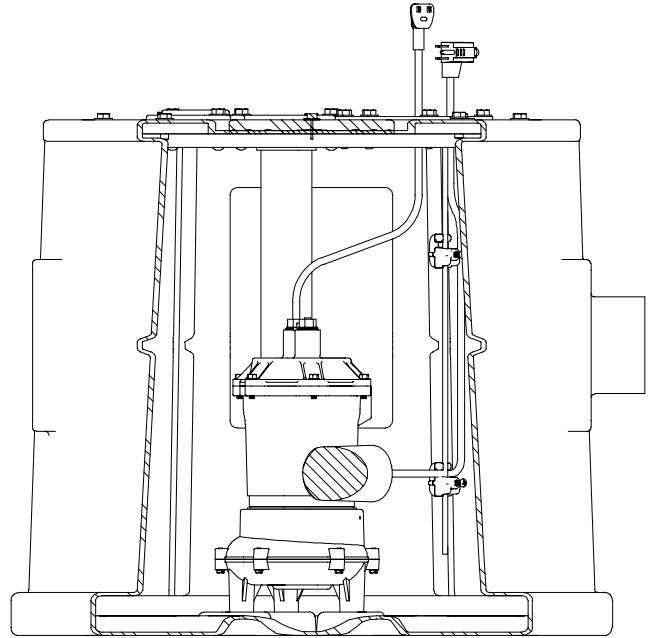

**PUMP PERFORMANCE**

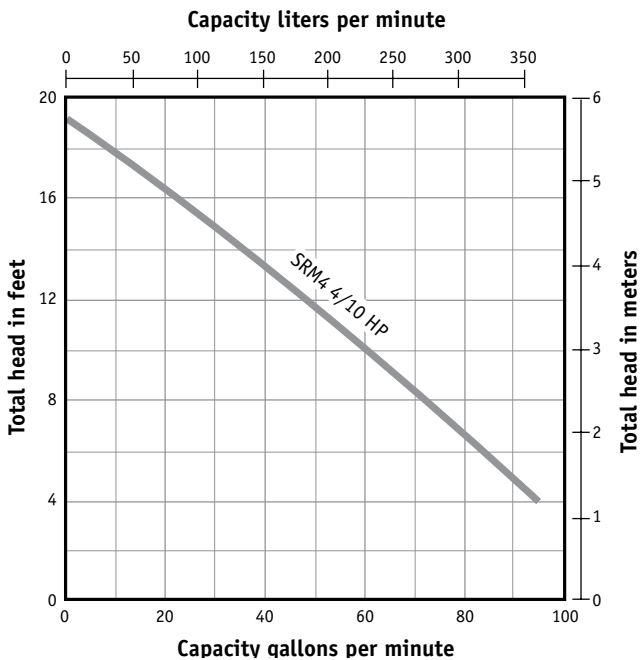

Myers | Customer Service: 888.987.8677 | Fax Orders: 888.840.7867 | [www.myerspump.com](http://www.myerspump.com) | Form No. M9161SSE (12/09)

Canada | Phone: 519.748.5470 | Fax: 519.748.2553