

Myers®

ME40/MW50 SERIES Submersible Sump, Effluent & Sewage Pumps Installation and Service Manual

Automatic and manual models. Single phase power only – 115 or 230 volt.

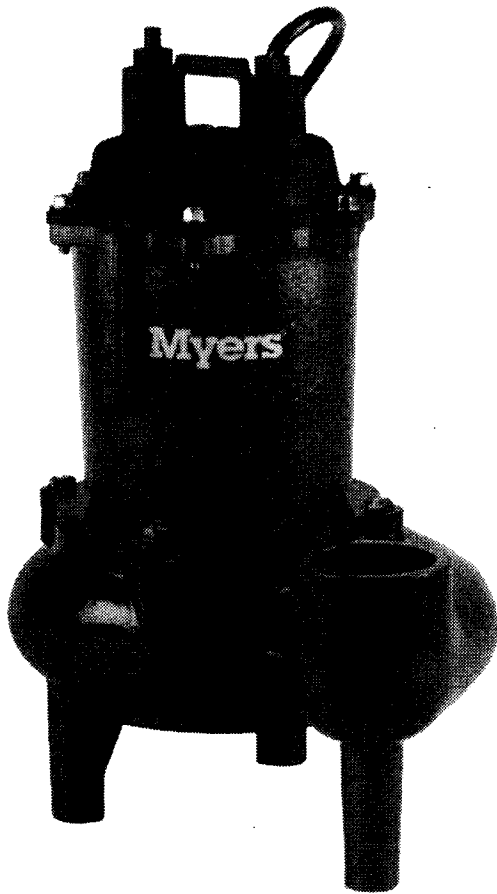

**MW50
SEWAGE PUMPS**



**ME40
EFFLUENT PUMPS**



TYPICAL SECTION DRAWING FOR ME40 SERIES

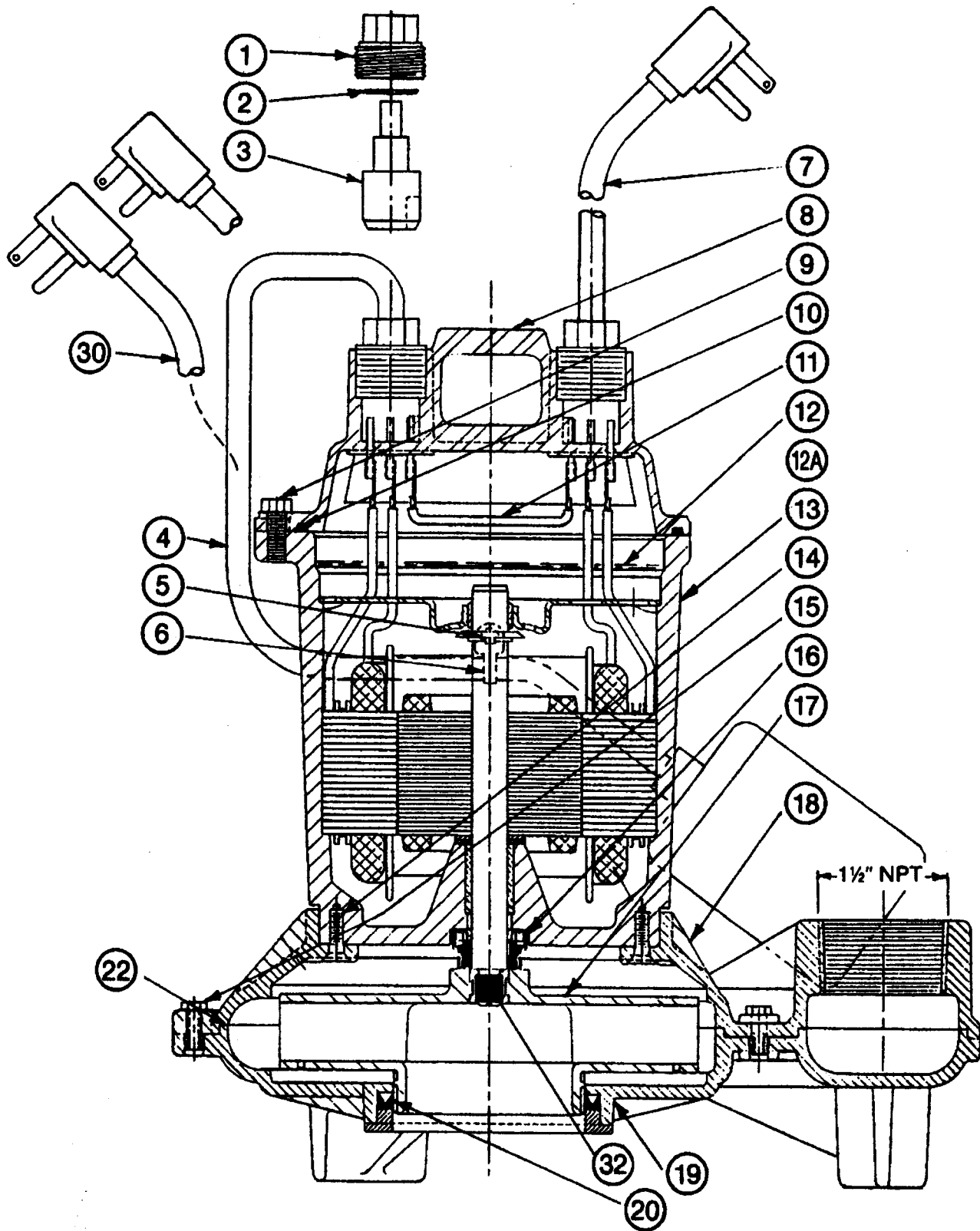

TYPICAL SECTION DRAWING FOR MW50 SERIES

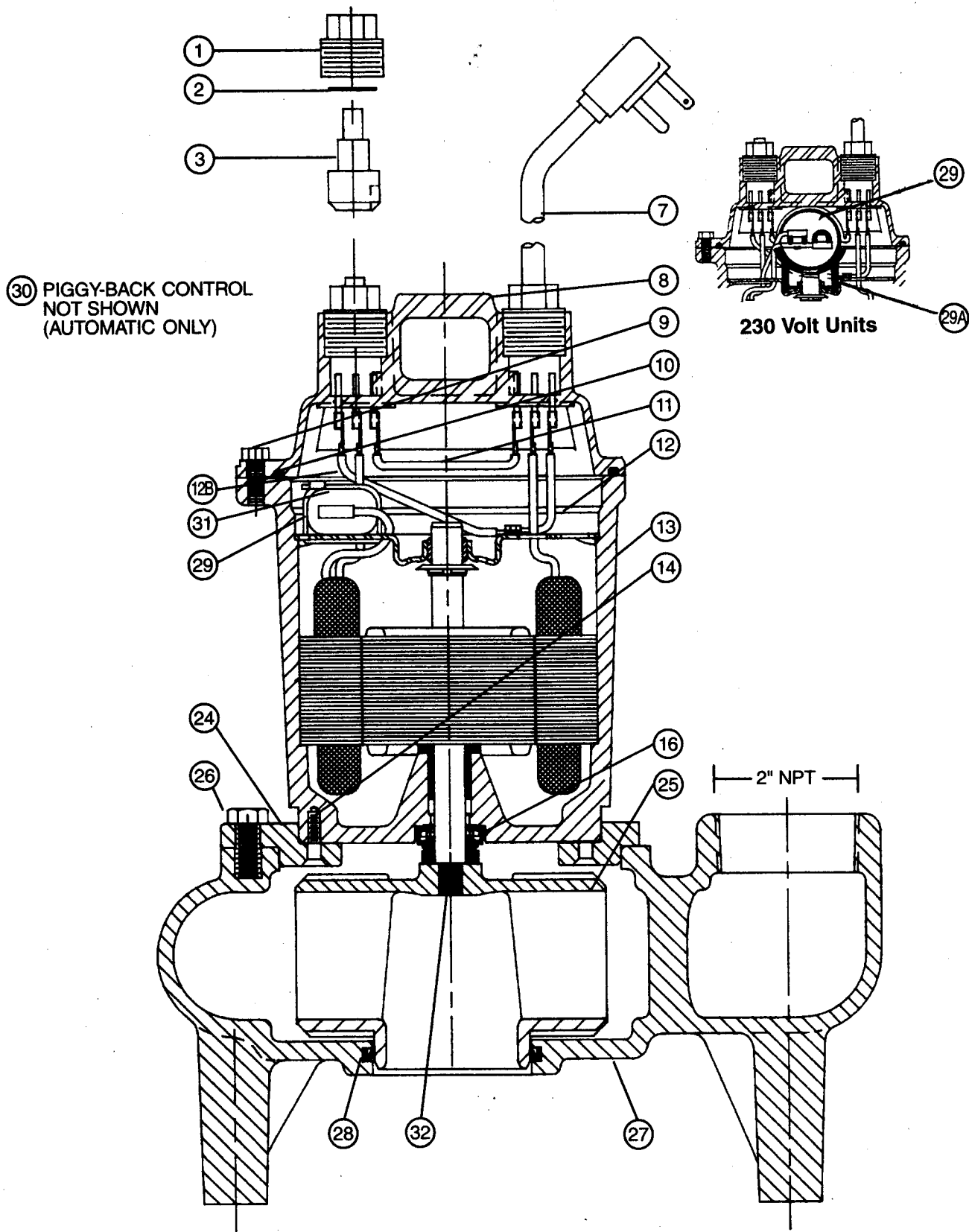

PARTS LIST ME40 & MW50

Ref. No.	Description	No. Req'd.	Part Numbers
1	Plug, nut (manual only)	1	24448A000
2	Washer (manual only)	1	05030A213
3	Plug, connector (manual only)	1	24449A000
4	Control, level (automatic only)	1	25798A500
5	Screw, #10 x 1/2" (automatic only)	1	09822A006
6	Tie, cable (automatic only)	1	17190A008
7	Cord, electric	1	See Chart
8	Cap, motor (not stamped)	1	24431C000
-	Plug, 1/8" pipe (not shown)	1	05022A068
9	Screw, machine, 1/4 x 7/8	6	18475A003
10	O-Ring, 5-1/2 x 5-1/4 x 1/8	1	05876A146
11	Wire, jumper	1	09859A800
12	Oil, transformer (1 gal.)	.2 gal.	11009A008
12A	Tube, plastic (group motor leads)	1	10649A122
12B	Screw, machine, #10 x 3/8	1	09822A032
13	Housing, with rotor & stator	1	See Chart
	Stator only	1	See Chart
	Rotor & shaft, ME40	1	25309A000
	Rotor & shaft, MW50	1	26166B000
	Washer, 1/16" Thk. TFE	1	05030A244
	Washer, 1/16" Thk. SST	1	05030A243
	Plate, bearing	1	24661B000
	Housing only	1	25308C001

Ref. No.	Description	No. Req'd	Part Numbers
14	Screw, machine, flat head	4	07597A030
15	Screw, machine, #10 x 5/8	11	18475A006
16	Seal, shaft	1	21607A001
17	Impeller	1	25301B000
18	Case, volute, upper half	1	25306D000
19	Case, volute, lower half	1	25307D000
20	Cup, U, HUVA, ME40	1	22835A007
22	Gasket, Vellumoid	1	25328C000
24	Plate, adaptor	1	26052C000
25	Impeller, plastic	1	26053B000
25	Impeller, brass	1	26028B000
26	Screw, cap 5/16-18 x 3/4	4	19100A004
27	Case, volute	1	26054D000
28	Cup, U, HUVA, MW50	1	22835A009
29	Capacitor (115 volt)	1	26167A000
29	Capacitor (230 volt)	1	23290A000
29A	Cradle, capacitor (230 volt)	1	26298B000
30	Control, 115 volt, 20'	1	21813B131
30	Control, 115 volt, 10'	1	21813B130
30	Control, 230 volt, 20'	1	21813B133
30	Control, 230 volt, 10'	1	21813B132
31	Tie wrap	1	17190A008
32	Sealant, Loctite 242	1	14550A002

CHART

Pump Catalog Number	Pump Engineer. Numbers	Pump Type	⑦ Cord, Electric	Cord Length	⑬ Housing w/Rotor & Stator	Stator Only
ME40A-11	25300D000	Automatic	21628B041	10'	25308C010	21599B022
ME40M-11	25300D001	Manual	21628B041	10'	25308C010	21599B022
ME40A-21	25300D002	Automatic	21628B042	10'	25308C011	21599B023
ME40M-21	25300D003	Manual	21628B042	10'	25308C011	21599B023
ME40AC-11	25300D010	Automatic	21628B018	20'	25308C010	21599B022
ME40MC-11	25300D011	Manual	21628B018	20'	25308C010	21599B022
ME40AC-21	25300D012	Automatic	21628B019	20'	25308C011	21599B023
ME40MC-21	25300D013	Manual	21628B019	20'	25308C011	21599B023
ME40P-1	25300D900	Automatic	21628B041	10'	25308C010	21599B022
ME40PC-1	25300D901	Automatic	21628B018	20'	25308C010	21599B022
ME40P-2	25300D902	Automatic	21628B042	10'	25308C011	21599B023
ME40PC-2	25300D903	Automatic	21628B019	20'	25308C011	21599B023
MW50-11	26088D001	Manual	21628B018	20'	25308C012	26165B000
MW50-21	26088D003	Manual	21628B019	20'	25308C013	26165B001
MW50-11B	26088D005	Manual	21628B018	20'	25308C012	26165B000
MW50-21B	26088D007	Manual	21628B019	20'	25308C013	26165B001
MW50-11P	26088D901	Automatic	21628B018	20'	25308C012	26165B000
MW50-21P	26088D903	Automatic	21628B019	20'	25308C013	26165B001
MW50-11PB	26088D912	Automatic	21628B018	20'	25308C012	26165B000
MW50-21PB	26088D913	Automatic	21628B019	20'	25308C013	26165B001

DESCRIPTION AND APPLICATION

ME40

Myers ME40 Series Pumps are single seal units, automatic or manual, designed for use in effluent dosing, Septic Tank Effluent Pumping (S.T.E.P.) or normal sump and general dewatering applications where higher pressure is required. **DO NOT USE FOR RAW SEWAGE.**

When used in Effluent dosing or S.T.E.P. applications, the pump must be installed in a separate tank or compartment at the discharge side of the septic tank. **NEVER INSTALL PUMP IN MAIN TANK WHERE SLUDGE COLLECTS.**

Impellers are enclosed two vane type to handle 3/4" spherical solids and are made of engineered thermoplastic. All pumps have a 1-1/2" NPT discharge tapping. **NOTE: DO NOT OVER TIGHTEN DISCHARGE PIPE INTO PUMP PLASTIC DISCHARGE FITTING.**

General

These pumps are available in 115 volt or 230 volt, single phase, (ME40) and 1/2 HP (MW50) motors. All units are single seal only, available in automatic or manual with either 10 foot or 20 foot power cords. All power cords have either 115 volt or 230 volt grounded plugs.

These pumps are NOT for use in swimming pools or fountains.

MW50

Myers MW50 Series Pumps are single seal units, automatic or manual, designed for use in residential sewage applications. These units are designed for handling raw sewage discharged for residential and light commercial developments.

Impellers are enclosed two vane type to handle 2" spherical solids and are made of engineered thermoplastic or bronze. The discharge pipe size is 2" NPT for attachment to most all sewage applications.

AIR LOCKING

A sump pump is said to be air locked if water traps air in the pump and it cannot get out, thus preventing the pump from operating.

The ME40/MW50 Sump Pumps have a 1/16" air vent hole in the impeller chamber to let out trapped air. If this hole becomes plugged, pump may air lock. As a secondary precaution a 1/8" hole should be drilled in the discharge pipe below the check valve. The check valve should be 12 to 18 inches above pump discharge. Do not put check valve directly into pump discharge opening.

PACKAGING

Each pump is packaged separately in a carton marked with a catalog number and Myers engineering number.

Catalog No.	Engineer. No.	HP	V	Ph	Cord Lgth.	Type
ME40A-11	25300D000	4/10	115	1	10'	Auto
ME40M-11	25300D001	4/10	115	1	10'	Manual
ME40A-21	25300D002	4/10	230	1	10'	Auto
ME40M-21	25300D003	4/10	230	1	10'	Manual
ME40AC-11	25300D010	4/10	115	1	20'	Auto
ME40MC-11	25300D011	4/10	115	1	20'	Manual
ME40AC-21	25300D012	4/10	230	1	20'	Auto
ME40MC-21	25300D013	4/10	230	1	20'	Manual
ME40P-1	25300D900	4/10	115	1	10'	Auto
ME40PC-1	25300D901	4/10	115	1	20'	Auto
ME40P-2	25300D902	4/10	230	1	10'	Auto
ME40PC-2	25300D903	4/10	230	1	20'	Auto
MW50-11	26088D001	1/2	115	1	20'	Manual
MW50-21	26088D003	1/2	230	1	20'	Manual
MW50-11B	26088D005	1/2	115	1	20'	Manual
MW50-21B	26088D007	1/2	230	1	20'	Manual
MW50-11P	26088D901	1/2	115	1	20'	Auto
MW50-21P	26088D903	1/2	230	1	20'	Auto
MW50-11PB	26088D912	1/2	115	1	20'	Auto
MW50-21PB	26088D913	1/2	230	1	20'	Auto

LEVEL CONTROLS

All pumps must use sealed level control switches for automatic operation. All automatic pumps have built-in level control float switches. The power cord has a GROUND PIN that plugs into a grounded receptacle. The grounded receptacle cannot be used in the wet sump or basin due to DANGER of current leakage.

Manual pumps can be made automatic with MLC or MFLC controls with a series plug. Plug the MLC or MFLC switch cord series plug into a proper voltage GROUNDED RECEPTACLE. Then plug the pump cord plug into the back of the switch cord series plug. **NOTE: The float control must be tethered a minimum 4" to pump or discharge pipe. Control must float free from pump and basin wall.**

On all duplex units or simplex installations with additional options like high water alarm, the power cord plug must be cut off and wired into a control panel or into a sealed junction box if used in wet sump or basin. The AWS-1 control also acts as a sealed junction box for connecting power cord to pump cord.

NOTE: The Model ME40 Sump/Effluent pump can be easily changed from one style, automatic or manual, to the other by only interchanging the plug ends of the float control with the manual plug. The ball float must be tethered with a cable clamp, as shown. DO NOT REMOVE THE MOTOR CAP.

The ME40P/MW50P Series pumps have a mechanical (mercury free) float switch with a 10 ft. or 20 ft. cord with a 115 volt or 230 volt series piggy-back plug with the switch mounted to the pump and tethered a minimum of 4" (ME40) or with cable tie for discharge pipe (MW50). Plug the switch cord plug into a proper voltage, properly grounded outlet and plug the power cord into the back of the switch cord and tape the cords to the discharge pipe every 12".

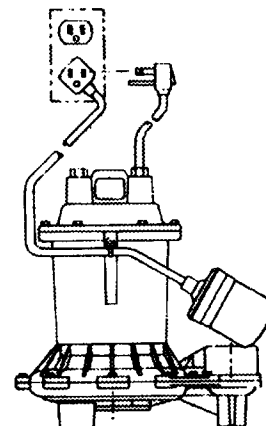

DESIGN OF PRESSURE SEWER SYSTEMS

MYERS has available complete computer SOFTWARE for designing PRESSURE SEWER SYSTEMS. This gives pipe sizes to use and gives exact flow from any pump or group of pumps in the system when operating simultaneously.

This design DISK for IBM® or COMPATIBLE computers is available to engineers on request.

MOTOR TYPE

The motors used in the ME40/MW50 pumps are pressed into the cast iron housings and surrounded by dielectric oil for the greatest heat dissipation. The ME40 uses a shaded pole, 4/10 HP, 1600 RPM motor. The MW50 uses a permanent split capacitor, 1/2 HP, 1625 RPM motor. Both units have class A motor insulation, are available in single phase 115 or 230 volt with overload protection and use a double sleeve bearing design. These pumps have no starting switches and do not require a control panel for simplex installation.

SAFETY WARNINGS

WARNING: Risk of electric shock. Pumps are supplied with a grounding conductor and grounding-type attachment plug on the power cord. To reduce the risk of electric shock, be certain that it is connected only to a properly grounded, grounding-type receptacle. DO NOT cut off ground pin or use an adapter fitting. DO NOT use an extension cord with this pump. Entire plug may be cut off if a control panel is used.

When wiring this pump follow all local electrical and safety codes and ordinances as well as the most recent National Electric Code (NEC-ANSI/NFPA 70).

All pumps have a GROUND WIRE that is connected to the motor. This wire goes to the receptacle or control panel which must be connected to a good outside GROUND such as a metal water pipe or GROUND STAKE driven at least 8 feet into the ground.

UL AND CSA APPROVAL

All pumps have UL and CSA approval. Myers is a SSPMA certified pump member.

INSTALLATION

WARNING: Basin or tank must be vented in accordance with local plumbing codes. These pumps are not designed for and CANNOT be installed in locations classified as hazardous in accordance with the National Electric Code ANSI/NFPA 70.

CAUTION: Never enter pump chamber after sewage or effluent has been in basin. Sewage water can give off methane, hydrogen sulfide and other gasses which are highly poisonous.

For this reason, Myers recommends installing effluent pumps with a quick removal system. The quick removal system may be a union or Cam-lok® coupling if the pipe or discharge hose is within reach from the surface, or a rail system type quick disconnect on deeper installations. See installation drawings for suggested installation.

The dosing tank or pumping chamber must be constructed of corrosion resistant materials and must be capable of withstanding all anticipated internal and external loads. It also must not allow infiltration or exfiltration. The tank must have provisions for anti-buoyancy. Access holes or covers must be adequate size and be accessible from the surface to allow for installation and maintenance of the system. Access covers

must be lockable or heavy enough to prevent easy access by unauthorized personnel. The pumping chamber holding capacity should be selected to allow for emergency conditions.

The discharge pipe must be the same size as the pump discharge (ME40 1-1/2") (MW50 2") or larger. In order to insure sufficient fluid velocity to prevent any residual solids from collecting in the discharge pipe, it is recommended that a minimum flow of 2' per second be maintained. (12 GPM through 1-1/2" pipe, 21 GPM through 2" pipe and 46 GPM through 3" pipe). It is recommended that PVC or equal pipe is used for corrosion resistance. A full flow (ball or gate) shut off valve must be installed to prevent back flow of effluent if the pump must be removed for service. A check valve must be installed on pressure sewer systems and on other systems where conditions allow to prevent backflow and to reduce wear on the pump system.

A high water alarm must be installed on a separate circuit from the pump circuit. The alarm should have the ability to be tested for proper operation.

POINTS TO CHECK IF PUMP DOES NOT RUN OR DOES NOT RUN PROPERLY

(1) Pump does not run or start when water is up in tank.

- (a) Check for blown fuse or tripped circuit breaker.
- (b) Check for defective level switch.
- (c) Where control panel is used be sure H-O-A switch is in the AUTO position. If it does not run, turn switch to the HAND position and if the pump runs then the trouble is in the automatic electrical system. Have ELECTRICIAN make electrical checks.

- (d) Check for burned out motor. Occasionally lightning can damage a motor even with lightning protection.
- (e) Where plug-in cords are used be sure contact blades are clean and making good contact. DO NOT USE PLUG-IN CORDS INSIDE A SUMP OR WET WELL.
- (f) Level control ball or weight may be stuck on side of basin. Be sure it floats freely.

(2) Pump runs but does not deliver flow.

- (a) Check for air lock. Start and stop pump several times, if this does not help it may be necessary to loosen a union in the discharge line to relieve air lock.
- (b) Check valve may be installed backwards. Check flow arrow on valve body. Check shut-off valve. It may be closed.
- (c) Check vertical elevation. It may be higher than pump can develop. (See pump curve).
- (d) Pump inlet may be plugged. Remove pump to check.

CAUTION: ALWAYS UNPLUG POWER CORDS OR TURN OFF ALL MAIN AND BRANCH CIRCUIT BREAKERS BEFORE DOING ANY WORK ON THE PUMP. If control panel is remote from pump, disconnect lead wires to motor so that no one can turn the circuit breaker back on.

BEFORE DISMANTLING PUMP FOR REPLACEMENT OF PARTS

Clean pump thoroughly. Knock off all scale and deposits. Submerge complete unit in Clorox solution for one hour before taking apart.

30" DIAMETER SIMPLEX ME40/MW50 UNION SYSTEM

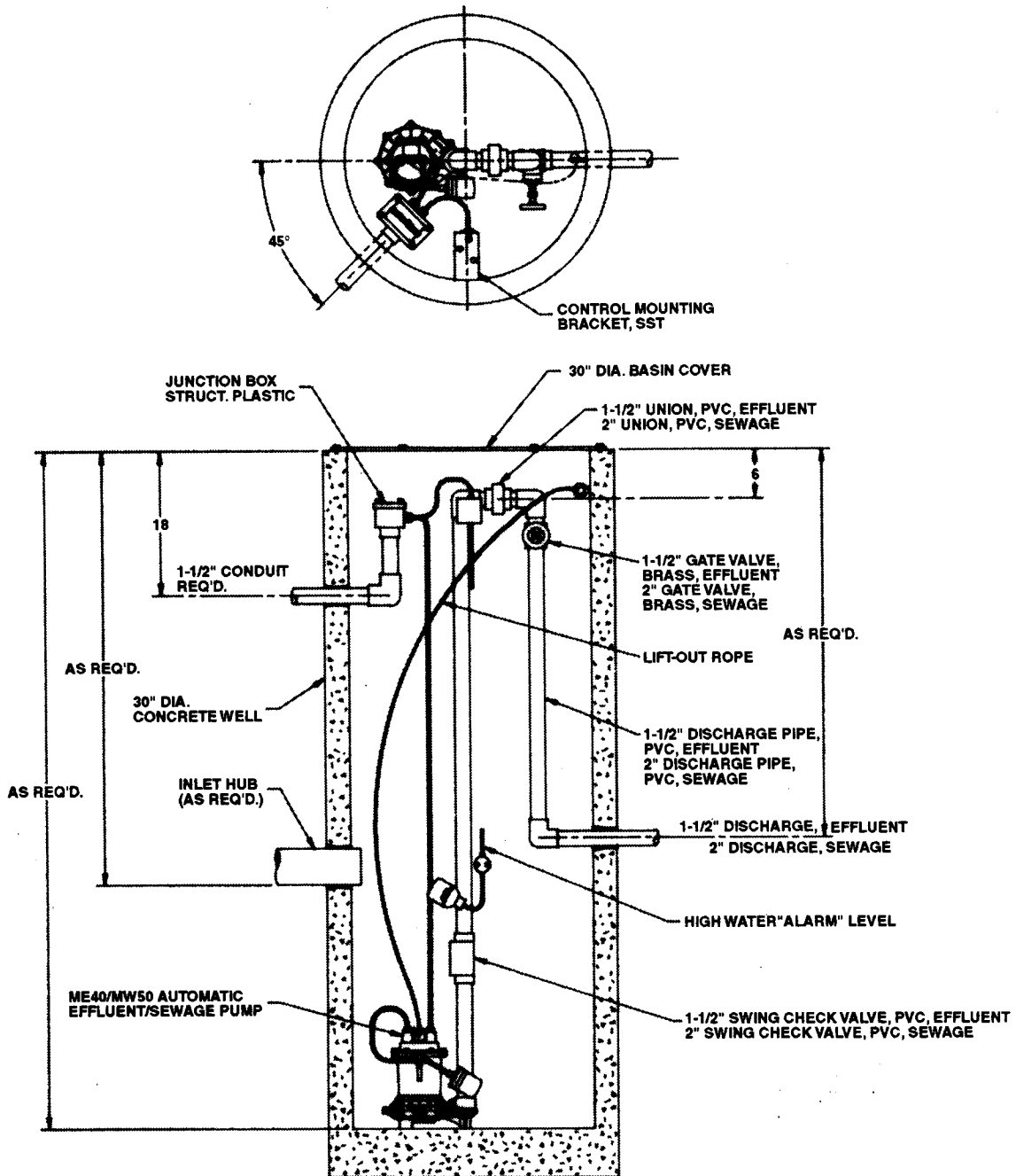

30" DIAMETER SIMPLEX ME40/MW50

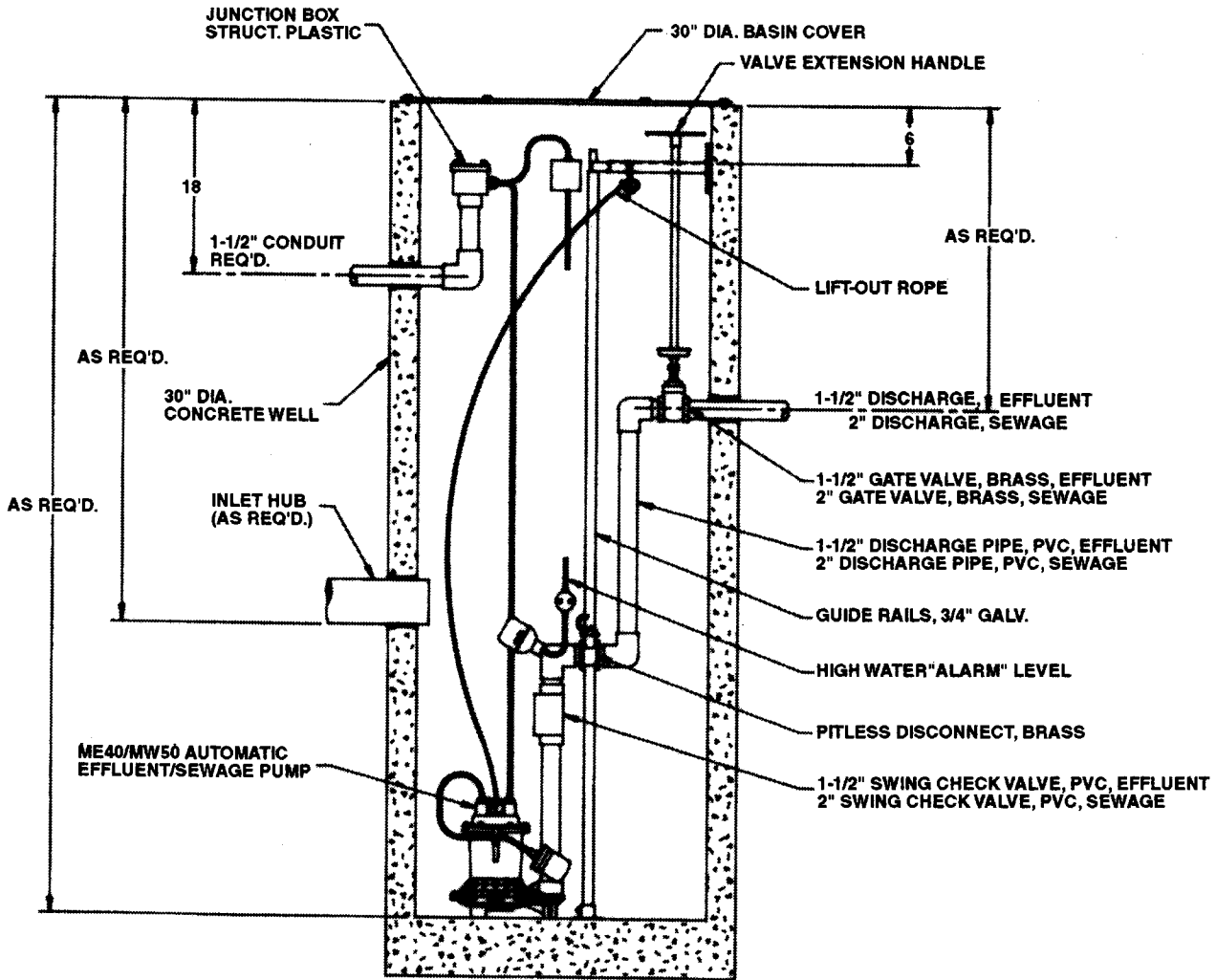
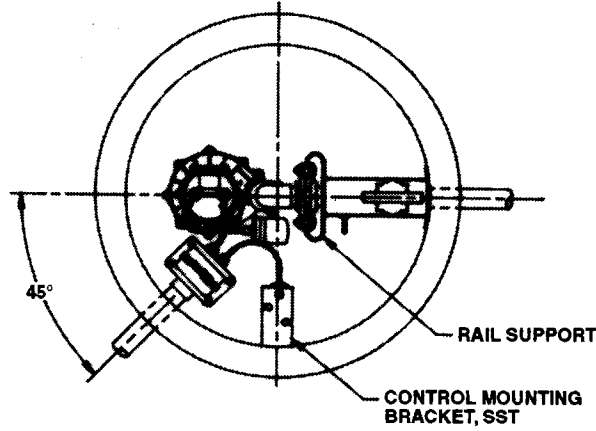

TO REPLACE POWER CORD OR AUTOMATIC CONTROL FLOAT

- (1) Use a wrench to loosen and remove thermoplastic nut from the cap socket. Use your fingers to pull and wiggle the cord end connector from the socket.
- (2) To replace either the power cord or automatic control float, align the half circle notch on the cord end connector with the half circle key in the socket. Press the connector into the socket all the way.
- (3) Slide the thermoplastic washer onto the top of the cord end connector.
- (4) Screw the thermoplastic nut into the socket. Tighten the nut snugly, but do not over-tighten. The nut may be tightened a little more after the connector has set over a period of time.
- (5) If replacing automatic control float be sure to tether float approximately 3-5/8".

FOR SHAFT SEAL ONLY REPLACEMENT

- (1) Remove the six screws from top thermoplastic cap and bump cap with plastic hammer to loosen.
- (2) Lay the cap back, do not disconnect wires from the cap. Pour all the oil from the pump. If the old seal failed there may be water in the oil and the old oil should be discarded.
- (3) Remove the eleven machine screws holding the volute halves together. Separate lower half volute from the upper half by using a rubber hammer and/or prying lightly with a screwdriver.
- (4) Lay pump on its side. Place a flat screwdriver in the slot in the bottom of the shaft and turn the impeller counter-clockwise to remove it from the shaft. A blow from a rubber hammer may be necessary to loosen the impeller.
- (5) Remove the rotating portion (ceramic) of the seal with fingers. Pry on the stationary portion (carbon) with a pair of slotted screwdrivers to remove from volute casing. Discard the old seal assembly parts. NEVER USE OLD SEAL PARTS, REBUILD PUMP WITH ONLY NEW SEAL ASSEMBLY.
- (6) Thoroughly clean the shaft and volute casing with a clean cloth. If the drained oil showed signs of water, then the motor should be air dried for several days to remove any remaining moisture.
- (7) Carefully remove the new seal assembly from the package. Add a film of new oil to the rubber O.D. on the stationary portion (carbon), and insert into the seal cavity on the volute casing. Using a pushing tool (a piece of PVC pipe works well), push on the rubber portion of the stationary seal until it is evenly seated into the seal cavity. With clean cloth, carefully wipe the seal face.
- (8) Remove the rotating portion (ceramic) from the package and carefully wipe with a clean cloth. Add a film of new oil onto the motor shaft. Slide the rotating portion over the shaft with the rubber surface of the seal facing away from the stationary seal face. Center the seal on the shaft.
- (9) Screw the impeller clockwise onto the shaft using a screwdriver to hold the shaft from turning and tighten impeller. Use Loctite or equal on shaft threads.
- (10) Check HUVA cup seal in volute case inlet. If worn, replace.
- (11) Place pump upright on top of lower volute half. Be sure mating parts are together and reassemble the eleven machine screws and tighten.
- (12) Check that the impeller turns freely.

- (13) Replace oil in motor housing using only Myers submersible transformer oil. The oil should be about 1/2" above the upper surface of the bearing plate.
- (14) Reinstall the top thermoplastic cap, making sure the O-ring is in position on the cap. Tighten the top six screws snug, but do not over-tighten.
- (15) Plug pump into receptacle to test operation. Pump must run quiet and free of vibration.

TO REPLACE MOTOR STATOR HOUSING ASSEMBLY AND SEAL

- (1) Stator assembly includes housing, stator, rotor with shaft, thrust washers and metal bearing plate. (See repair parts list).
- (2) Remove the six screws from top thermoplastic cap and bump cap with plastic hammer to loosen.
- (3) Disconnect the four motor lead wires from the cap pin terminals and remove cap. Pour all the oil from the pump.
- (4) Remove the eleven machine screws holding the volute halves together. Separate lower half volute from the upper half by using a rubber hammer and/or prying lightly with a screwdriver.
- (5) Lay pump on its side. Place a flat screwdriver in the slot in the bottom of the shaft and turn the impeller counter-clockwise to remove it from the shaft. A blow from a rubber hammer may be necessary to loosen the impeller. Discard old seal part.
- (6) Remove the four flat head screws holding the upper half of volute to housing. Note position of discharge in relation to switch clamp.
- (7) To assemble the new ceramic seal seat into your new stator housing assembly, clean the seat cavity thoroughly and apply grease to the O.D. of the rubber seal around the ceramic seat. Use fingers or rod of soft material to push the ceramic seat into the housing cavity. Clean seat face to remove any dirt and apply a coating of light oil. NEVER USE OLD SEAL PARTS. USE ONLY COMPLETELY NEW SEALS.
- (8) Assemble the upper half of the volute to housing with the four flat head screws. Position discharge the same as before in relation to switch clamp.
- (9) Make sure the shaft surface is clean and lightly oiled. Press by hand the rotating half of the shaft seal onto the shaft. Be sure the rotating carbon washer is positioned adjacent to the ceramic seat.
- (10) Screw the impeller clockwise onto the shaft using a screwdriver to hold the shaft from turning and tighten impeller. Use Loctite or equal on shaft threads.
- (11) Check HUVA cup seal in volute case inlet. If worn, replace.
- (12) Place pump upright on top of lower volute half. Be sure mating parts are together and reassemble the eleven machine screws and tighten.
- (13) Check that the impeller turns freely.
- (14) Guide the four motor wires up through a common hole in the bearing plate and place the protective plastic tube over the four motor wires.
- (15) Position the O-ring into cap and reconnect the four motor wires as shown in wiring diagram. The two green ground wires connect to the pins nearest the 'G' marked on the cap.
- (16) Put oil in the motor housing using only Myers submersible transformer oil. The oil should be about 1/2" above the surface of the bearing plate.

- (17) Reinstall the top thermoplastic cap, making sure the O-ring is in position on the cap. Tighten the top six screws snug, but do not over-tighten.
- (18) Be sure the 1/8 NPT pipe plug is in the top cap.
- (19) Plug pump into receptacle to test operation. Pump must run quiet and free of vibration.

NOTE: When replacing top cap with a new one, be sure the jumper wire and pipe plug are in place. See wiring diagram. Tether level control to motor housing with float extended approximately 3-5/8".

WIRING DIAGRAM

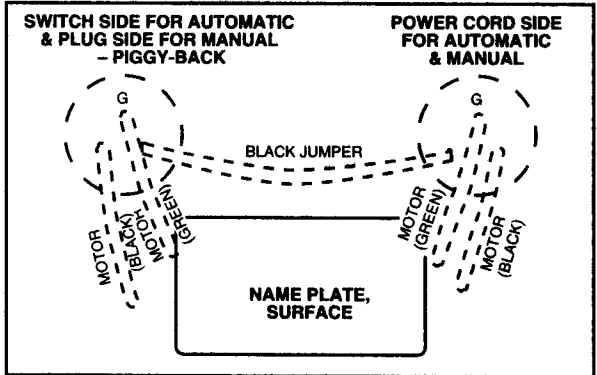

MOTOR RESISTANCE CHART

HP	Speed	V	Ph	Winding Resistance in Ohms	Max. Amps	Locked Rotor Amps
4/10	1600	115	1	1.2	12.0	16.0
4/10	1600	230	1	4.3	6.0	8.2
1/2	1625	115	1	2.0	9.0	17.6
1/2	1625	230	1	9.1	4.5	8.8

ME40 DIMENSIONAL DRAWING

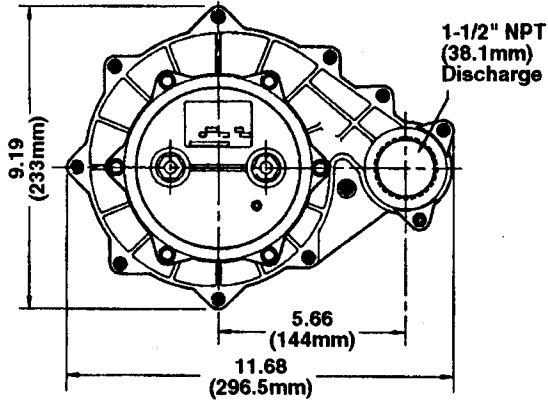
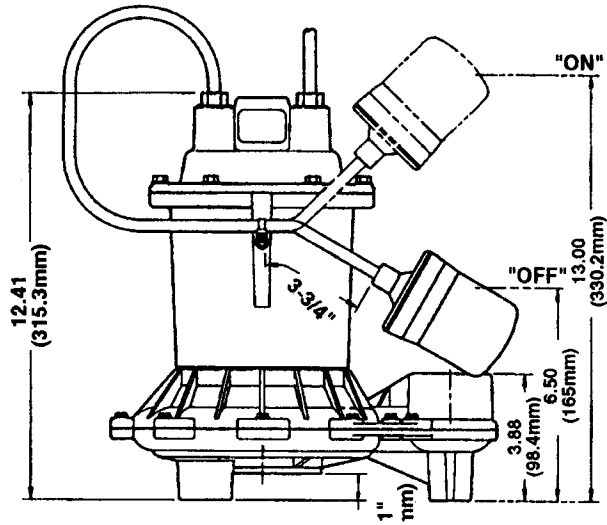

ME40 PERFORMANCE

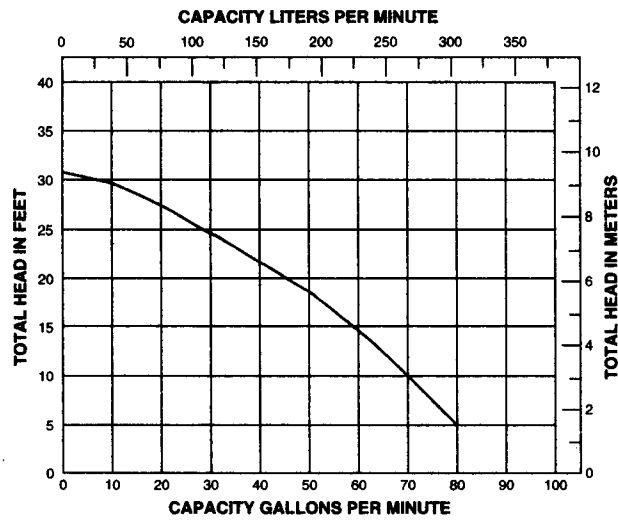

MW50 DIMENSIONAL DRAWING

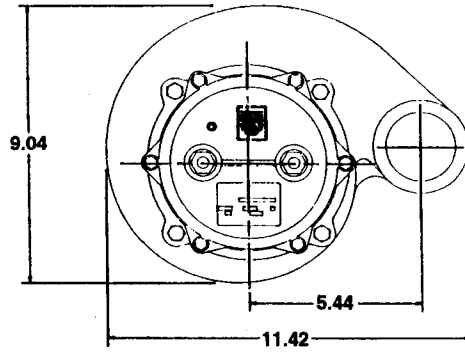
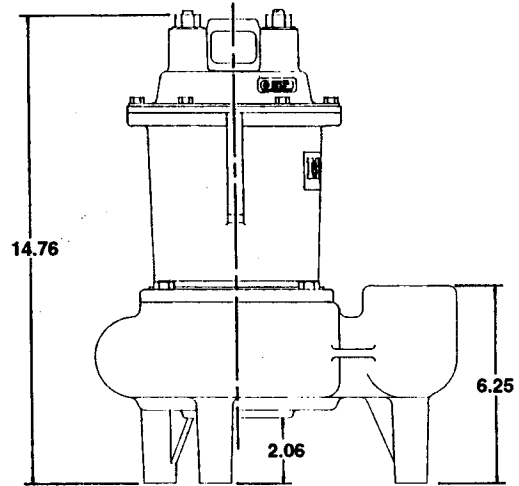

MW50 PERFORMANCE

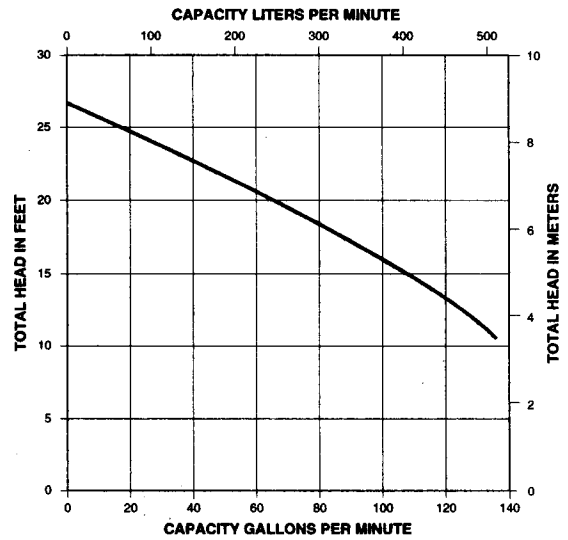

MYERS LIMITED WARRANTY

F.E. MYERS warrants that its products are free from defects in material and workmanship for a period of 12 months from the date of installation or 18 months from the date of manufacture, whichever occurs first.

During the warranty period, and subject to the conditions hereinafter set forth, F.E. MYERS will repair or replace to the original user or consumer parts which prove defective due to defective materials or workmanship of MYERS. This remedy is exclusive and is the only remedy available to any person with respect to such MYERS product. Contact your nearest authorized MYERS distributor or MYERS for warranty service. At all times MYERS shall have and possess the sole right and option to determine whether to repair or replace defective equipment, parts or components.

Start-up reports and electrical system schematics may be required to support warranty claims. This warranty is effective only if MYERS supplied or authorized control panels are used.

LABOR, ETC. COSTS: MYERS shall IN NO EVENT be responsible or liable for the cost of field labor or other charges incurred by any customer in removing and/or reaffixing any MYERS product, part or component thereof.

THIS WARRANTY WILL NOT APPLY: (a) to defects or malfunctions resulting from failure to properly install, operate or maintain the unit in accordance with printed instructions provided; (b) to failures resulting from abuse, accident, or negligence; (c) to normal maintenance services and the parts used in connection with such service; (d) to units which are not installed in accordance with applicable codes, ordinances and good trade practices; or (e) if the unit is moved from its original installation locations, and (f) unit is used for purposes other than for what it was designed and manufactured.

RETURN OR REPLACED COMPONENTS: Any item to be replaced under this Warranty must be returned to MYERS at Ashland, Ohio, or such place as MYERS may designate, freight prepaid.

PRODUCT IMPROVEMENTS: MYERS reserves the right to change or improve its products or any portions thereof without being obligated to provide such a change or improvement for units sold and/or shipped prior to such change or improvement.

WARRANTY EXCLUSIONS: As to any specific MYERS product, after the expiration of the time period of the warranty applicable thereto as set forth above. **THERE WILL BE NO WARRANTIES, INCLUDING ANY IMPLIED WARRANTIES OF MERCHANTABILITY OR FITNESS FOR ANY PARTICULAR PURPOSE.**

Some states do not allow limitations on how long an implied warranty lasts, so the above limitation may not apply to you. No warranties or representations at any time made by any representative of MYERS shall vary or expand the provisions hereof.

LIABILITY LIMITATION: IN NO EVENT SHALL MYERS BE LIABLE OR RESPONSIBLE FOR CONSEQUENTIAL, INCIDENTAL OR SPECIAL DAMAGES RESULTING FROM OR RELATED IN ANY MANNER TO ANY MYERS PRODUCT OR PARTS THEREOF.

Some states do not allow the exclusion or limitation of incidental or consequential damages, so the above limitation or exclusion may not apply to you.

This Warranty gives you specific legal rights and you may also have other rights which vary from state to state.

Direct all notices, etc. to: Warranty Service Department, F.E. Myers, 1101 Myers Parkway, Ashland, Ohio 44805.

Myers®

F.E. Myers, 1101 Myers Parkway, Ashland, Ohio 44805-1969
419/289-1144, FAX: 419/289-6658, TLX: 948-7443