

**Myers®**

**P51, P52 & P102 Series  
Submersible Sump & Effluent  
S.T.E.P. Pumps**

**Installation and Service Manual**

For double seal units with or without seal leak detectors. Single phase power only.

---

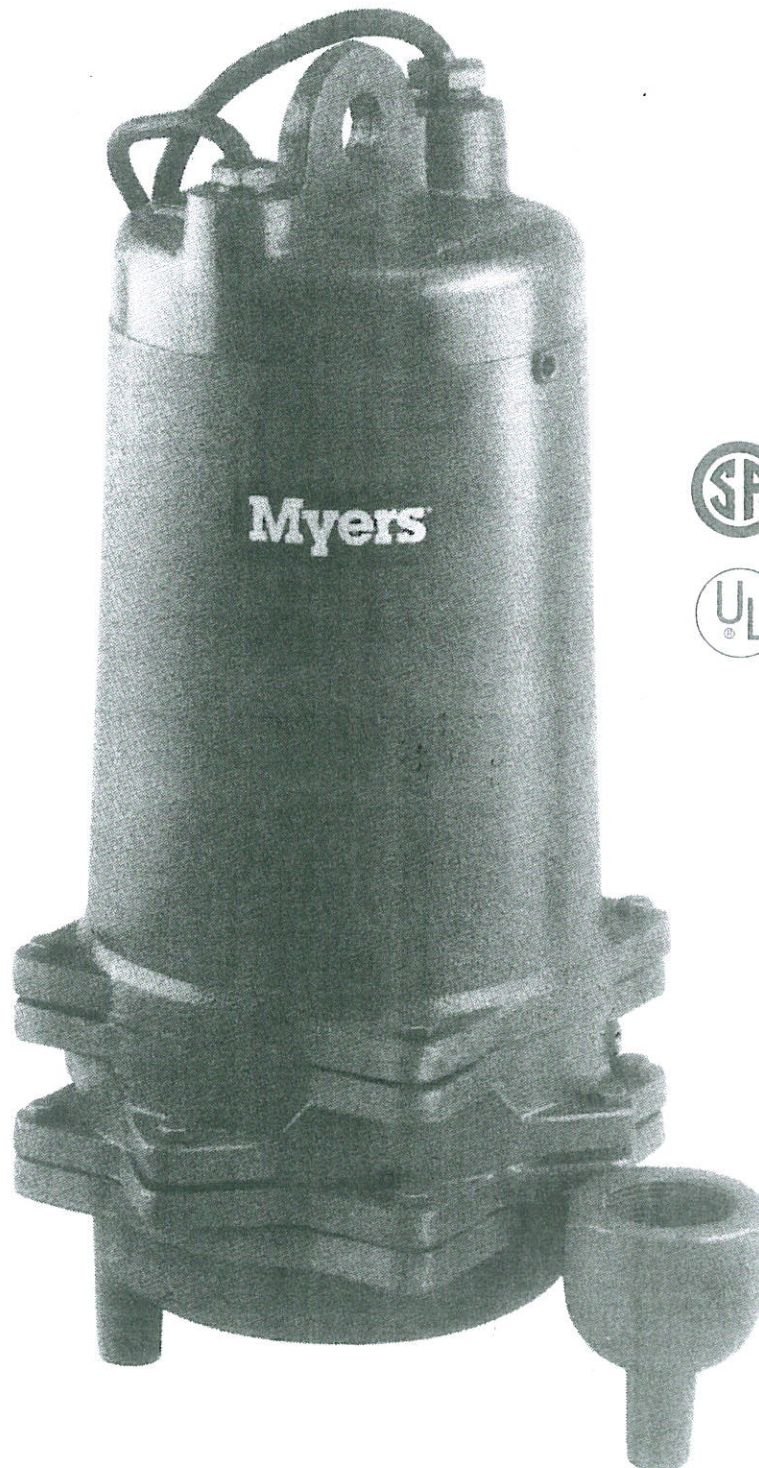

TYPICAL SECTION DRAWING FOR P SERIES DOUBLE SEAL PUMP

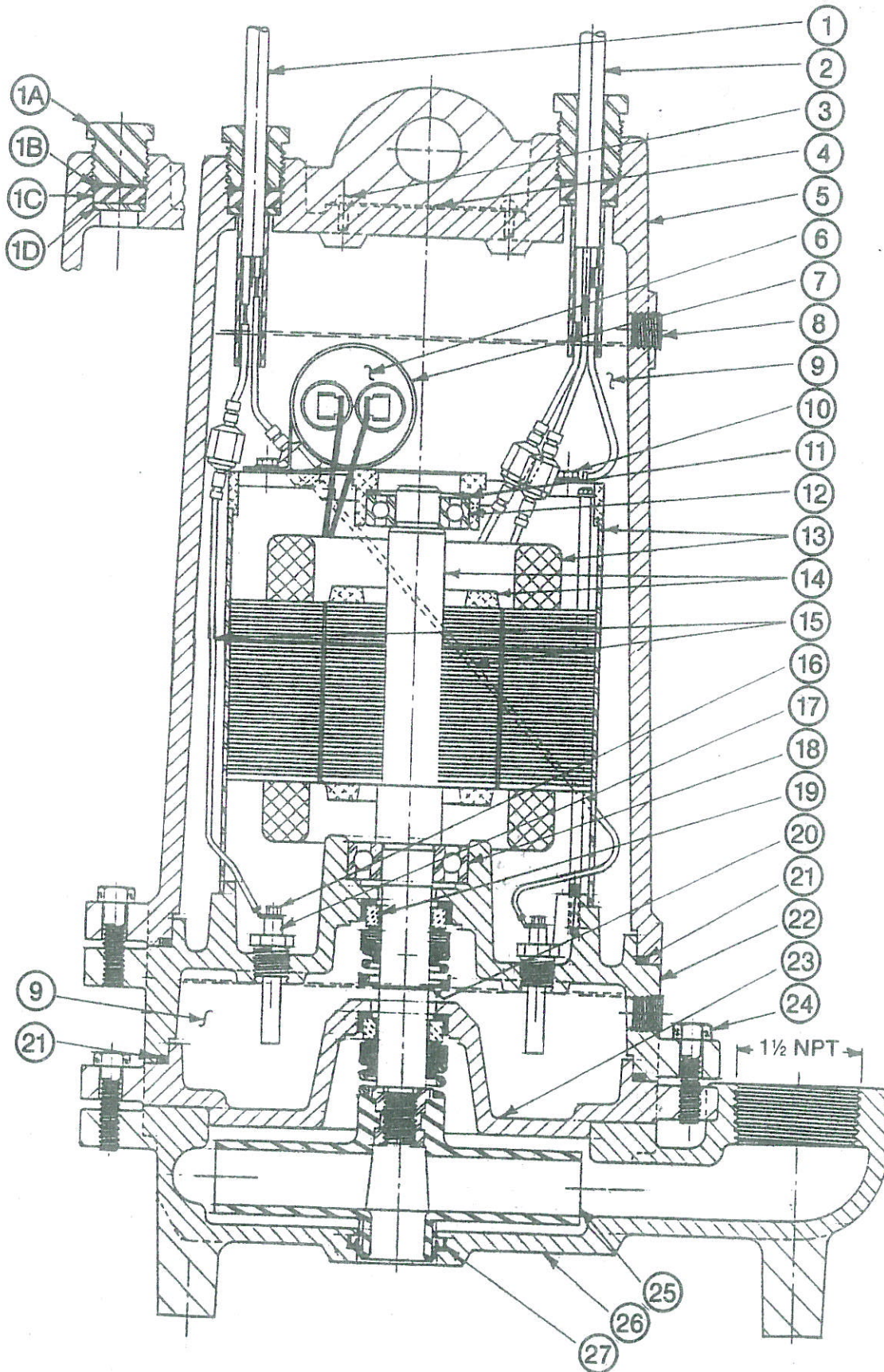

## PARTS LIST

| Ref. No. | Description                        | No. Req'd. | Part Numbers |           |           |           |           |           |
|----------|------------------------------------|------------|--------------|-----------|-----------|-----------|-----------|-----------|
|          |                                    |            | P51D         | P52D      | P102D     | P51       | P52       | P102      |
| 1A       | Nut, cord, solid                   | 1          | -            | -         | -         | 25341A002 | 25341A002 | 25341A002 |
| 1B       | Washer, 1/32 thick                 | 1          | -            | -         | -         | 05030A234 | 05030A234 | 05030A234 |
| 1C       | Gasket, rubber                     | 1          | -            | -         | -         | 05014A193 | 05014A193 | 05014A139 |
| 1D       | Washer, 3/32 thick                 | 1          | -            | -         | -         | 05030A235 | 05030A235 | 05030A235 |
| 1        | Cord, sensor                       | 1          | 25339B000    | 25339B000 | 25339B000 | -         | -         | -         |
| 2        | Cord, power                        | 1          | 25338B002    | 25338B002 | 25338B002 | 25338B000 | 25338B001 | 25338B001 |
| 3        | Screw, drive                       | 2          | 05160A004    | 05160A004 | 05160A004 | 05160A004 | 05160A004 | 05160A004 |
| 4        | Name plate, blank                  | 1          | 25488A000    | 25488A000 | 25488A000 | 25488A000 | 25488A000 | 25488A000 |
| 5        | Housing, motor                     | 2          | 25327D000    | 25327D000 | 25327D000 | 25327D000 | 25327D000 | 25327D000 |
| 6        | Capacitor, 20 mfd.                 | 1          | 23838A000    | 23838A000 | 23838A000 | 23838A000 | 23838A000 | 23838A000 |
| 7        | Clip, capacitor                    | 1          | 20333A004    | 20333A004 | 20333A004 | 20333A004 | 20333A004 | 20333A004 |
| 8        | Plug, 1/4" pipe, w/sensor cord     | 2          | 05022A009    | 05022A009 | 05022A009 | 05022A009 | 05022A009 | 05022A009 |
| 8        | Plug, 1/4" pipe, w/out sensor cord | 4*         | 05022A009    | 05022A009 | 05022A009 | 05022A009 | 05022A009 | 05022A009 |
| 9        | Oil, transformer (5 gal. can)      | 1.125 gal  | 11009A006    | 11009A006 | 11009A006 | 11009A006 | 11009A006 | 11009A006 |
| 10       | Screw, tap., #10 x 3/8"            | 2          | 09822A032    | 09822A032 | 09822A032 | 09822A032 | 09822A032 | 09822A032 |
| 11       | Washer, bearing                    | 1          | 19331A005    | 19331A005 | 19331A005 | 19331A005 | 19331A005 | 19331A005 |
| 12       | Bearing, ball, upper               | 1          | 08565A013    | 08565A013 | 08565A013 | 08565A013 | 08565A013 | 08565A013 |
| 13       | Stator with shell                  | 1          | 25484C000    | 25484C001 | 25484C006 | 25484C000 | 25484C001 | 25484C006 |
| 14       | Rotor with shaft                   | 1          | 25487B000    | 25487B000 | 25487B001 | 25487B000 | 25487B000 | 25487B001 |
| 15       | Wire, electrode                    | 2          | 21792A004    | 21792A004 | 21792A004 | -         | -         | -         |
| 16       | Screw, #6 x 1/4                    | 2          | 05434A025    | 05434A025 | 05434A025 | -         | -         | -         |
| 17       | Probe, seal leak                   | 2          | 25343A000    | 25343A000 | 25343A000 | -         | -         | -         |
| 18       | Bearing, ball, lower               | 1          | 08565A022    | 08565A022 | 08565A022 | 08565A022 | 08565A022 | 08565A022 |
| 19       | Seal, 3/4" shaft                   | 2          | 25370A000    | 25370A000 | 25370A000 | 25370A000 | 25370A000 | 25370A000 |
| 20       | Ring, retaining                    | 1          | 12558A033    | 12558A033 | 12558A033 | 12558A033 | 12558A033 | 12558A033 |
| 21       | Gasket, tetraseal, 7 x 6-3/4 x 1/8 | 2          | 05014A181    | 05014A181 | 05014A181 | 05014A181 | 05014A181 | 05014A181 |
| 22       | Housing, seal                      | 1          | 25369D000    | 25369D000 | 25369D000 | 25369D000 | 25369D000 | 25369D000 |
| 23       | Plate, bottom                      | 1          | 25368D000    | 25368D000 | 25368D000 | 25368D000 | 25368D000 | 25368D000 |
| 24       | Screw, cap, 5/16 x 1-1/4"          | 12         | 19100A012    | 19100A012 | 19100A012 | 19100A012 | 19100A012 | 19100A012 |
| 25       | Impeller, plastic (std. series)    | 1          | 25332B010    | 25332B010 | 25332B000 | 25332B010 | 25332B010 | 25332B000 |
| 25       | Impeller, brass ('B' series)       | 1          | 25332B110    | 25332B110 | 25332B100 | 25332B110 | 25332B110 | 25332B100 |
| 26       | Case, volute                       | 1          | 25330D000    | 25330D000 | 25330D000 | 25330D000 | 25330D000 | 25330D000 |
| 27       | Cup, U, HUVA                       | 1          | 22835A006    | 22835A006 | 22835A006 | 22835A006 | 22835A006 | 22835A006 |
| 35       | Screw, #10-32 x 3/8                | 1          | 06106A042    | 06106A042 | 06106A042 | 06106A042 | 06106A042 | 06106A042 |
| 36       | Washer, flat                       | 1          | 05030A242    | 05030A242 | 05030A242 | 05030A242 | 05030A242 | 05030A242 |

\* 2 pipe plugs assemble in place of seal leak probes when sensor cord is not used.

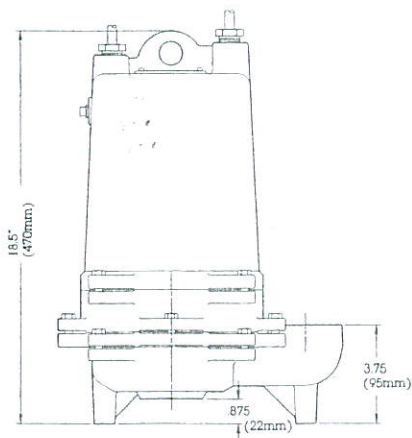
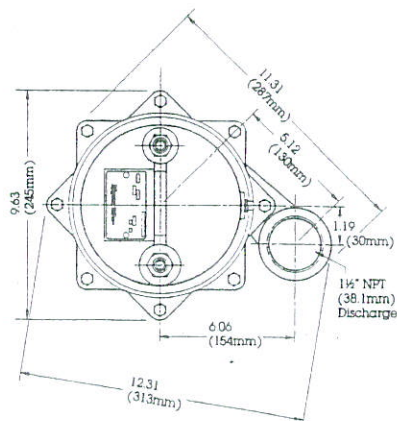

**NOTE: READ THESE INSTRUCTIONS CAREFULLY BEFORE ATTEMPTING TO INSTALL PUMP.**

**DESCRIPTION AND APPLICATION**

Myers 'P' Series Pumps are double seal units designed for use in Septic Tank Effluent Pumping (S.T.E.P.) or normal sump and general dewatering applications where higher pressure is required. **DO NOT USE FOR RAW SEWAGE.**

When used in S.T.E.P. applications, the pump must be installed in a separate tank or compartment at the discharge side of the septic tank. **NEVER INSTALL PUMP IN MAIN TANK WHERE SLUDGE COLLECTS.**

These pumps are available in single phase only as 1/2 HP - 115V, 1/2 HP - 230V, and 1 HP - 230 V, either with seal leak detectors (P51D) or without seal leak detectors (P51). All units with seal leak detectors and all duplex installations must be used with a control box. All power cords (14/3) and seal leak detector cords (16/2) are 20 feet long. All units without seal leak detectors have grounded plugs on the power cord.

Impellers are enclosed single vane type to handle 3/4" spherical solids and are available made of engineered thermoplastic or cast brass. All pumps have a 1-1/2" NPT discharge tapping.

**WARNING! THESE PUMPS ARE NOT APPROVED FOR, AND SHOULD NOT BE USED IN SWIMMING POOLS OR FOUNTAINS.**

**AIR LOCKING**

A sump pump is said to be air locked if water traps air in the pump and it cannot get out, thus preventing the pump from operating.

In installations of this type a 1/8" hole should be drilled in the discharge pipe below the check valve. The check valve should be 12 to 18 inches above pump discharge. Do not put check valve directly into pump discharge opening.

**PACKAGING**

Each pump is packaged separately in a carton marked with a catalog number and Myers engineering number.

| Cat. No. | Eng. No.  | HP  | V   | Ph | Seal Leak Detectors | Impeller Material |
|----------|-----------|-----|-----|----|---------------------|-------------------|
| P51D     | 25345D000 | 1/2 | 115 | 1  | Yes                 | Plastic*          |
| P52D     | 25345D001 | 1/2 | 230 | 1  | Yes                 | Plastic*          |
| P102D    | 25345D002 | 1   | 230 | 1  | Yes                 | Plastic*          |
| P51      | 25345D010 | 1/2 | 115 | 1  | No                  | Plastic*          |
| P52      | 25345D011 | 1/2 | 230 | 1  | No                  | Plastic*          |
| P102     | 25345D012 | 1   | 230 | 1  | No                  | Plastic*          |
| P51DB    | 25345D100 | 1/2 | 115 | 1  | Yes                 | Brass*            |
| P52DB    | 25345D101 | 1/2 | 230 | 1  | Yes                 | Brass*            |
| P102DB   | 25345D102 | 1   | 230 | 1  | Yes                 | Brass*            |
| P51B     | 25345D010 | 1/2 | 115 | 1  | No                  | Brass*            |
| P52B     | 25345D011 | 1/2 | 230 | 1  | No                  | Brass*            |
| P102B    | 25345D012 | 1   | 230 | 1  | No                  | Brass*            |

\* Plastic (Engineered Thermoplastic), Brass (Cast Brass).

**LEVEL CONTROLS**

All pumps must use sealed level control switches for automatic operation. MLC and MFLC controls have sealed switches that are 1 HP rated at 230 volts.

Simplex single phase pumps can be made automatic by attaching MFLC or MLC controls to the pump. These switches have a fixed draw off level of 8 to 10" and can be used up to 1 HP. Simplex systems may also use on/off pilot mercury control switches with control box and magnetic starter. All duplex systems must use pilot mercury control switches with control box and magnetic starters.

Plug-in cords can be used on all the single phase pumps without seal leak detector. This cord has a GROUND pin that plugs into a grounded receptacle. The grounded receptacle cannot be used in the wet sump or basin due to DANGER of current leakage.

Sealed junction boxes must be used in wet sumps or basins to make connections to motor cord. The AWS-1 control also acts as a sealed junction box for connecting power cord to pump cord.

**DOUBLE SEAL PUMPS**

All pumps in this series have two seals with an oil chamber between the seals so that the seal faces of both the lower and upper seals are oil lubricated for longer life and greater protection against water leaking into the motor windings. These double seal units are made with and without a seal leak detector.

The leak detector in the oil seal chamber detects any water leakage into the chamber and turns on a red signal light in the control panel. Pumps should be removed from the sump and seals replaced after the seal light shows in the panel. Control panels must be used for pumps having the seal leak detectors and seal leak detectors must be wired as illustrated in this instruction manual.

Double seal pumps without the seal leak detector should be pulled and the lower seal chamber checked in 12 to 18 months.

**DESIGN OF PRESSURE SEWER SYSTEMS**

MYERS has available complete computer SOFTWARE for designing PRESSURE SEWER SYSTEMS. This gives pipe sizes to use and gives exact flow from any pump or group of pumps in the system when operating simultaneously.

This design DISK for IBM® or COMPATIBLE computers is available to engineers on request.

**MOTOR TYPE**

Motors are 3/4 frame, 1/2 and 1 HP single phase, 60 Hertz, 3450 R.P.M., permanent split-capacitor (PSC) type with built-in on winding overload protection and has class B insulation. Motor does not require a start switch or start relay. It has upper and lower ball bearings and is oil cooled and lubricated.

## SAFETY WARNINGS

**WARNING:** Risk of electric shock. Pumps without seal leak detectors are supplied with a grounding conduction and grounding-type attachment plug on the power cord. To reduce the risk of electric shock, be certain that it is connected only to a properly grounded, grounding-type receptacle. **DO NOT** cut off ground pin or use an adapter fitting. **DO NOT** use an extension cord with this pump. Entire plug may be cut off if a control panel is used.

When wiring this pump follow all local electrical and safety codes and ordinances as well as the most recent National Electric Code (NEC-ANSI/NFPA 70).

All pumps have a GROUND WIRE that is connected to a screw in the metal motor housing. This wire goes to the receptacle or control box which must be connected to a good outside GROUND such as a metal water pipe or GROUND STAKE driven at least 8 feet into the ground.

## UL, CSA & ETL APPROVAL

All pumps have CSA and UL approval. Myers is a SSPMA certified pump member.

## INSTALLATION

**WARNING:** Basin or tank must be vented in accordance with local plumbing codes. These pumps are not designed for and **CANNOT** be installed in locations classified as hazardous in accordance with the National Electric Code ANSI/NFPA 70.

**CAUTION:** Never enter pump chamber after sewage or effluent has been in basin. Sewage water can give off methane, hydrogen sulfide and other gasses which are highly poisonous.

For this reason, Myers recommends installing the P series effluent pumps with a quick removal system. The quick removal system may be a union or Cam-lok® coupling if the piping or discharge hose is within reach from the surface or a rail system type quick disconnect on deeper installations. See installation drawings for suggested installation.

The dosing tank or pumping chamber must be constructed of corrosion resistant materials and must be capable of withstanding all anticipated internal and external loads. It also must not allow infiltration or exfiltration. The tank must have provisions for anti-buoyancy. Access holes or covers must be of adequate size and be accessible from the surface to allow for installation and maintenance of the system. Access covers must be lockable or heavy enough to prevent easy access by unauthorized personnel. The pumping chamber holding capacity should be selected to allow for emergency conditions.

The discharge pipe must be the same size as the pump discharge (1-1/2") or larger. In order to insure sufficient fluid velocity to prevent any residual solids from collecting in the discharge pipe, it is recommended that a minimum flow of 2 feet per second be maintained. (12 GPM through 1-1/2" pipe, 21 GPM through 2" pipe and 46 GPM through 3" pipe). It is recommended that PVC or equal pipe is used for

corrosion resistance. A full flow (ball or gate) shut off valve must be installed to prevent back flow of effluent if the pump must be removed for service. A check valve must be installed on pressure sewer systems and on other systems where conditions allow to prevent backflow and to reduce wear on the pump system.

A high water alarm must be installed on a separate circuit from the pump circuit. The alarm should have the ability to be tested for proper operation.

## POINTS TO CHECK IF PUMP DOES NOT RUN OR DOES NOT RUN PROPERLY

1. **Pump does not run or start when water is up in tank.**
  - a. Check for blown fuse or tripped circuit breaker.
  - b. Check for defective level switch.
  - c. Where control panel is used be sure H-O-A switch is in the AUTO position. If it does not run, turn switch to the HAND position and if the pump runs then the trouble is in the automatic electrical system. Have ELECTRICIAN make electrical checks.
  - d. Check for burned out motor. Occasionally lightning can damage a motor even with lightning protection.
  - e. Where plug-in cords are used be sure contact blades are clean and making good contact. **DO NOT USE PLUG-IN CORDS INSIDE A SUMP OR WET WELL.**
2. **Pump runs but does not deliver flow.**
  - a. Check for air lock. Start and stop pump several times, if this does not help it may be necessary to loosen a union in the discharge line to relieve air lock.
  - b. Check valve may be installed backwards. Check flow arrow on valve body. Check shut-off valve. It may be closed.
  - c. Check vertical elevation. It may be higher than pump can develop. (See pump curve).
  - d. Pump inlet may be plugged. Remove pump to check.
  - e. Level control ball or weight may be stuck on side of basin. Be sure it floats freely.

**CAUTION:** ALWAYS UNPLUG POWER CORDS OR TURN OFF ALL MAIN AND BRANCH CIRCUIT BREAKERS BEFORE DOING ANY WORK ON THE PUMP. If control panel is remote from pump, disconnect lead wires to motor so that no one can turn the circuit breaker back on.

## BEFORE DISMANTLING PUMP FOR REPLACEMENT OF PARTS

Clean pump thoroughly. Knock off all scale and deposits. Use sandblast if possible. Submerge complete unit in Clorox solution for one hour before taking apart.

## 24" DIAMETER SIMPLEX P51 HOSE SYSTEM

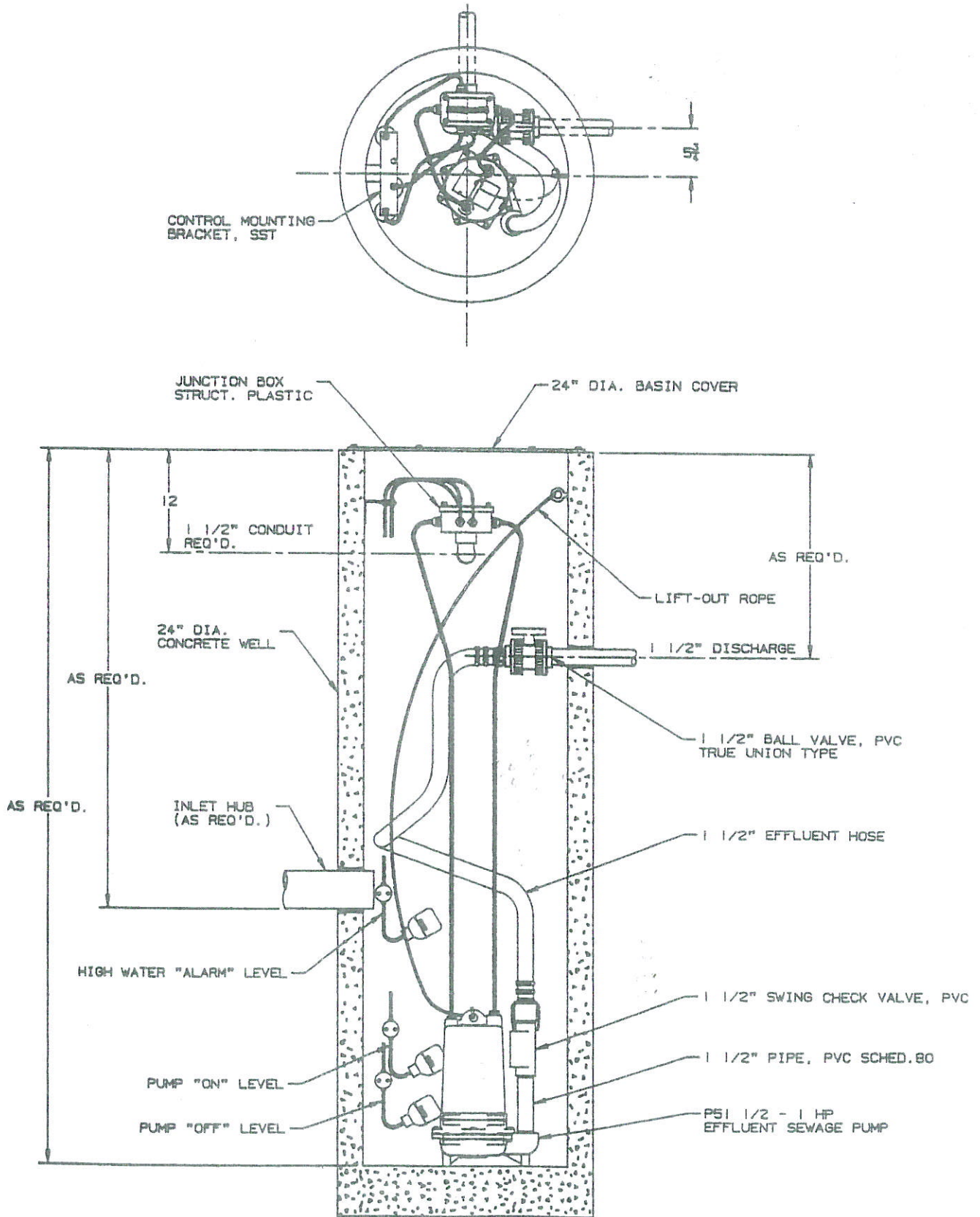

### 30" DIAMETER SIMPLEX P51 RAIL SYSTEM

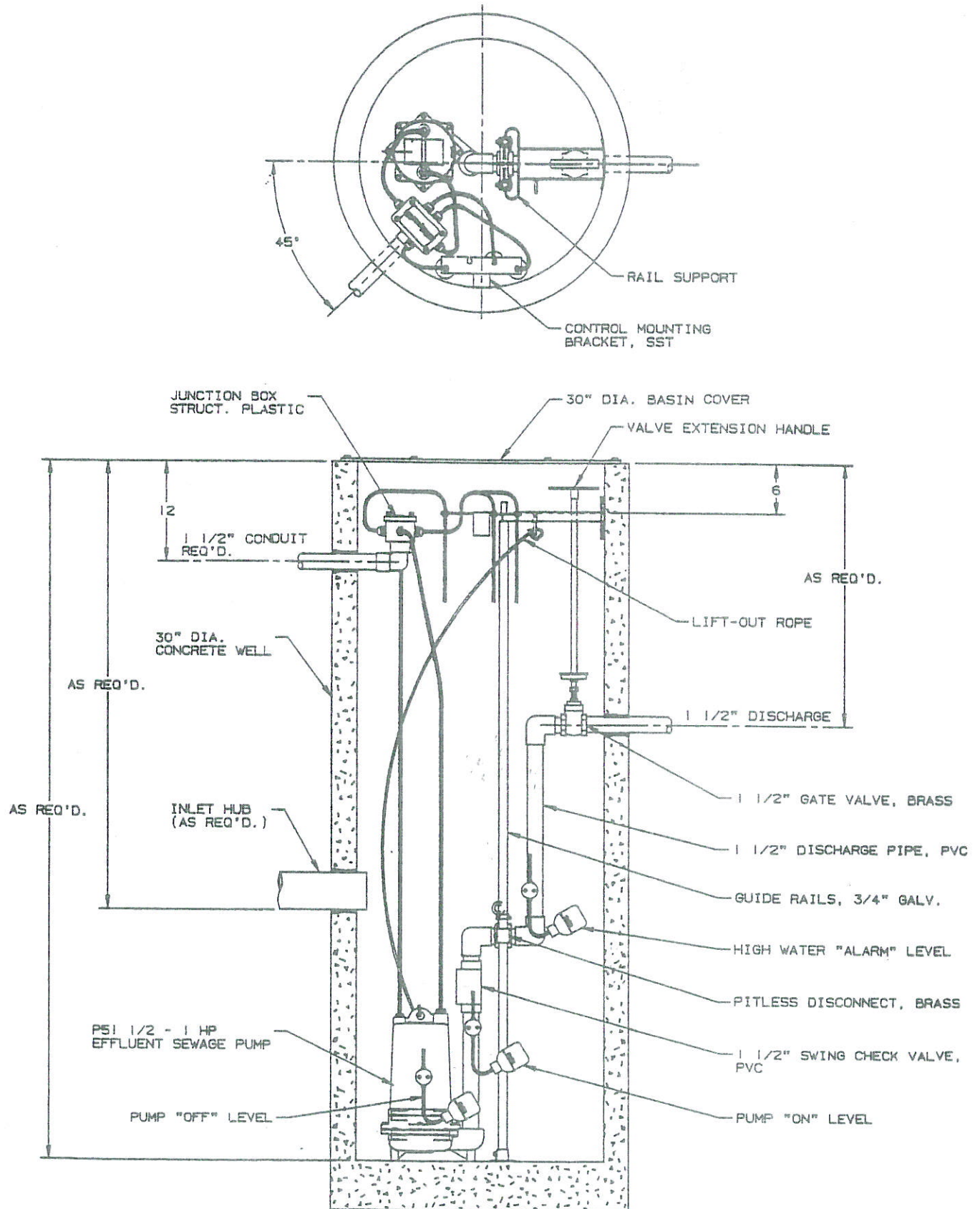

## TO REPLACE CAPACITORS ONLY

All of the motors are of the permanent split capacitor type and have no relays or starting switch. They have only a starting capacitor that is in the circuit for both starting and running conditions.

1. Remove oil fill plug near the top of the motor and pour the oil out.
2. Loosen the plug nuts around the cords until they are loose enough to push the cords down inside of the motor housing.
3. Remove the four bolts from the motor housing and bump the housing with a plastic hammer to loosen. Lay the pump on its side.
4. Remove the housing carefully to be sure that enough cord is pushed into the housing to create no tension on the cords.
5. Slide motor housing up far enough to expose the capacitor and to be able to lay the housing down.

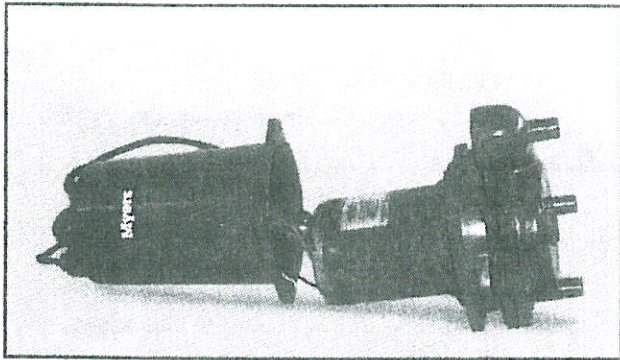

6. Disconnect wiring from capacitor and loosen capacitor clamp and slide out capacitor. Replace with new capacitor, tighten and reconnect. Wiring diagram is given in these instructions.
7. Check all wiring connectors to be sure they are secure.
8. Be sure tetraseal gasket is in place.
9. Slide motor housing back onto pump while pulling the cords out slowly. Assemble the motor housing with the four bolts.
10. Re-assemble cord nuts. Be sure washers are seated and cords are pulled up to stop against the washers. Tighten nuts securely.
11. Put pump upright and refill motor with Myers submersible motor oil. DO NOT OVER FILL WITH OIL. With pump upright fill oil to bottom of oil fill tapping. Replace oil fill plug.
12. Be sure pump turns freely before connecting to power. Turn pump on side and turn impeller, using screwdriver in slotted shaft. Plug pump into receptacle to test operation. Pump must run quiet and free of vibration.

## TO REPLACE POWER CORD AND/OR SEAL LEAK DETECTOR CORD

1. Remove motor housing as described above. Disconnect the push-together terminals and

remove the ground screw from the power cord if being replaced.

2. Completely unscrew cord bushing to be replaced and remove cord assembly from housing. Be sure remaining terminals are secure on the wires.
3. Replace with proper cord with fittings. Push cord into the motor housing far enough to make proper connections. Re-connect ground wire if replacing power cord and securely connect the wires correctly. See wiring diagram in these instructions.
4. Assemble cords and motor housing as described in "Capacitor Replacement." Fill with oil as noted and be sure pump turns freely before connecting to power.

## TO REPLACE MOTOR STATOR AND SHELL

1. Remove motor housing as described above.
2. Disconnect all leads from power and seal leak cords and ground wire and set pump upright.
3. Loosen the four long screws holding the motor and remove slowly. If unit has seal leak probes be sure to feed the wires through the slots as the motor is being removed.
4. Either remove previous capacitor and clamp from old motor and assemble onto new stator and shell or replace with a new capacitor and assemble the two capacitor leads per wiring diagram.
5. Position bearing spring washer on top of upper ball bearing.
6. Tighten terminal screws of seal leak probes and feed wires through the motor slots.

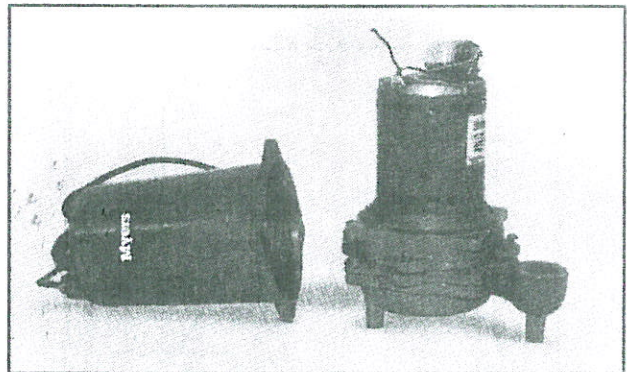

7. Position the 'stator with shell' into place and line up screws with the bosses and tighten the (4) long screws. Extend probe wires out through the slots. Lay unit down in line with motor housing.
8. Be sure pump turns freely with screwdriver in impeller end of shaft.
9. Re-connect all terminals securely per wiring diagram.
10. Be sure tetraseal gasket is in place.
11. Reassemble motor housing and fill with oil as noted above in "Capacitor Replacement."



## SHAFT SEAL REPLACEMENT

1. Remove plugs in motor housing and in seal housing and drain oil.
2. Remove four bolts holding the volute case and bump with a plastic hammer to loosen and remove case.

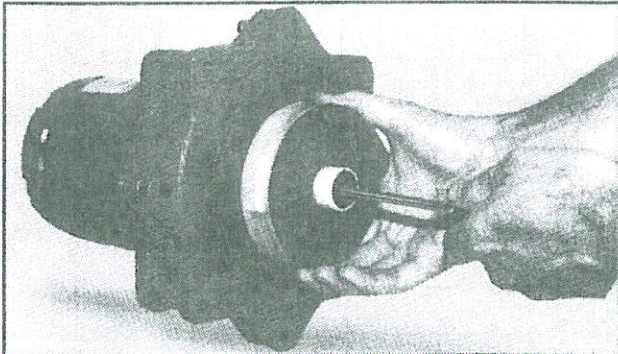

3. Remove Allen head screw by turning counterclockwise. Hold shaft with screwdriver through impeller eye and unscrew impeller, turn counterclockwise.
4. Pry off seal bellows and ceramic seat. Break seats if necessary to get out since they must be replaced with new parts.
5. NEVER USE OLD SEAL PARTS. USE ONLY COMPLETELY NEW SEALS.
6. **If only replacing the lower seal** it is not necessary to disassemble further and it is not necessary to drain oil out of the motor housing, just the seal housing.
7. To remove the upper seal remove four bolts holding the bottom plate and remove bottom plate.

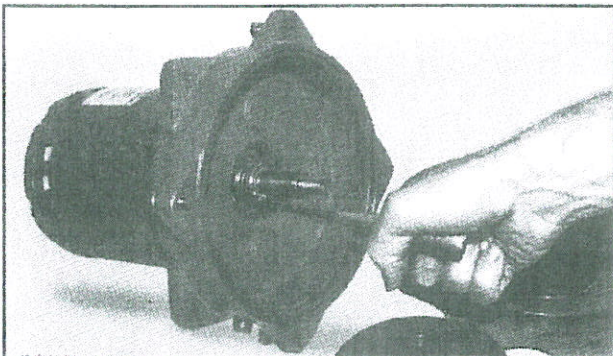

8. Remove snap ring with snap ring pliers. Pry off upper seal bellows and ceramic seat.
9. If no water has entered motor housing (check winding with ohmmeter or megger) wipe seal chambers thoroughly and replace seals. (Use seal retainer plate on upper seal only, do not use on lower seal.) Clean seal faces and use light oil on face before installing bellows part of seal.
10. Check HUVA cup seal in volute case inlet. If worn, replace.
11. Be sure tetraseal seal is in position (replace if worn) and reassemble.
12. Replace oil in motor housing and seal chamber. Use only Myers submersible oil.
13. Be sure pump turns freely before connecting to power.

## WIRING DIAGRAM

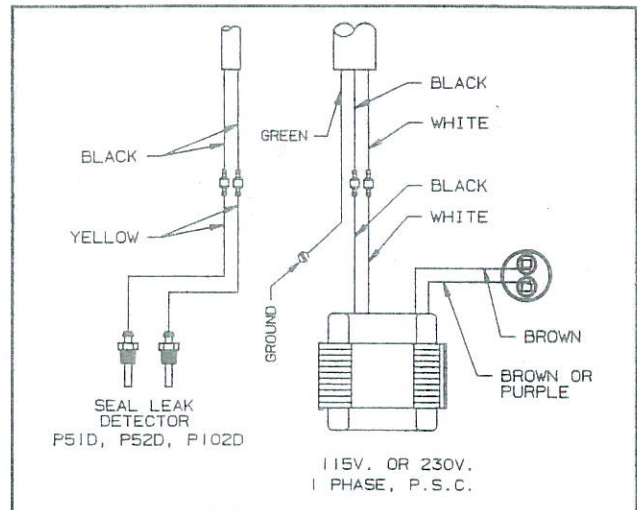

## MOTOR RESISTANCE CHART

| HP  | SPEED | V   | PH | WINDING RESISTANCE<br>IN OHMS |                           | MAX.<br>AMPS | LOCKED<br>ROTOR<br>AMPS |
|-----|-------|-----|----|-------------------------------|---------------------------|--------------|-------------------------|
|     |       |     |    | BLACK TO<br>WHITE             | BRN. TO BRN.<br>OR PURPLE |              |                         |
| 1/2 | 3450  | 115 | 1  | 0.8/0.9                       | 14.7                      | 12           | 29.6                    |
| 1/2 | 3450  | 230 | 1  | 9.8                           | 19.7                      | 6            | 15.0                    |
| 1   | 3450  | 230 | 1  | 3.0/2.6                       | 16.0/14.0                 | 8            | 18.5                    |

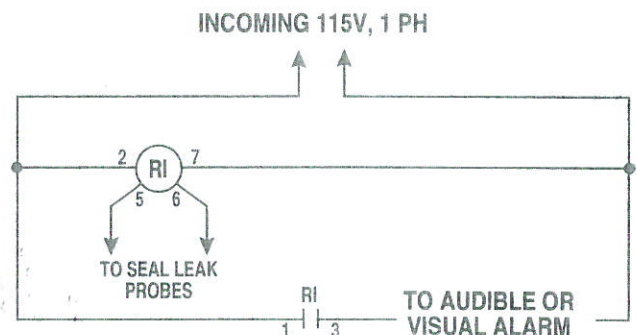

## MOISTURE SENSOR SEAL PROBE CIRCUIT

Relay - SSAC INC. #LLC44A5A  
Socket - STANDARD 8-PIN PLUG IN TYPE  
IF MYERS PANEL IS USED, SEE BELOW.

### Pumps:

P51D, P51DB

### Required Panel:

CMEP(SL)-11S, -11SW, -11D or -11DW

### Pumps:

P52D, P52DB,  
P102D, P102DB

### Required Panel:

CMEP(SL)-21S, -21SW, -21D or -21DW

# PERFORMANCE CURVE

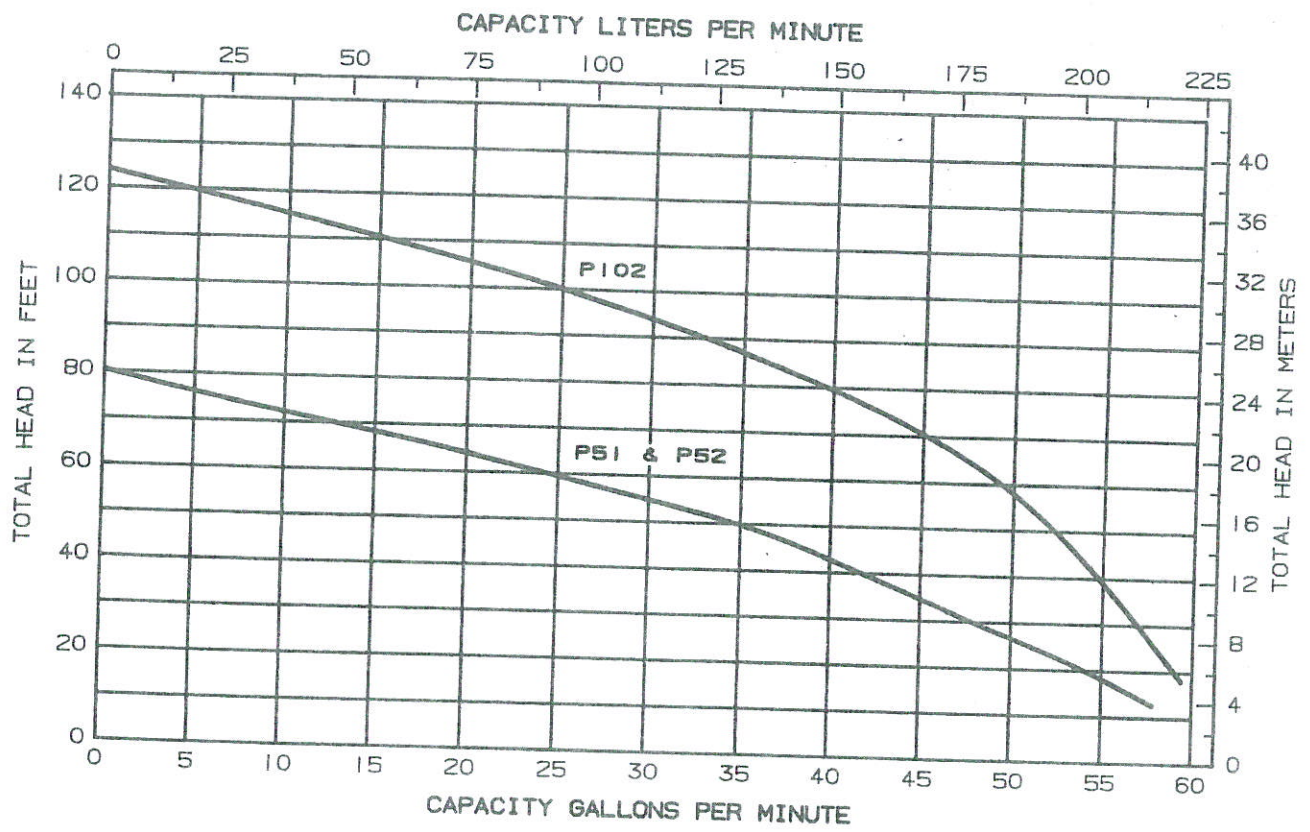

## MYERS LIMITED WARRANTY

F.E. MYERS warrants that its products are free from defects in material and workmanship for a period of 12 months from the date of installation or 18 months from the date of manufacture, whichever occurs first.

During the warranty period, and subject to the conditions hereinafter set forth, F.E. MYERS will repair or replace to the original user or consumer parts which prove defective due to defective materials or workmanship of MYERS. This remedy is exclusive and is the only remedy available to any person with respect to such MYERS product. Contact your nearest authorized MYERS distributor or MYERS for warranty service. At all times MYERS shall have and possess the sole right and option to determine whether to repair or replace defective equipment, parts or components.

Start-up reports and electrical system schematics may be required to support warranty claims. This warranty is effective only if MYERS supplied or authorized control panels are used.

LABOR, ETC. COSTS: MYERS shall IN NO EVENT be responsible or liable for the cost of field labor or other charges incurred by any customer in removing and/or reaffixing any MYERS product, part or component thereof.

THIS WARRANTY WILL NOT APPLY: (a) to defects or malfunctions resulting from failure to properly install, operate or maintain the unit in accordance with printed instructions provided; (b) to failures resulting from abuse, accident, or negligence; (c) to normal maintenance services and the parts used in connection with such service; (d) to units which are not installed in accordance with applicable codes, ordinances and good trade practices; or (e) if the unit is moved from its original installation locations, and (f) unit is used for purposes other than for what it was designed and manufactured.

RETURN OR REPLACED COMPONENTS: any item to be replaced under this Warranty must be returned to MYERS at Ashland, Ohio, or such place as MYERS may designate, freight prepaid.

PRODUCT IMPROVEMENTS: MYERS reserves the right to change or improve its products or any portions thereof without being obligated to provide such a change or improvement for units sold and/or shipped prior to such change or improvement.

WARRANTY EXCLUSIONS: as to any specific MYERS product, after the expiration of the time period of the warranty applicable thereto as set forth above. THERE WILL BE NO WARRANTIES, INCLUDING ANY IMPLIED WARRANTIES OF MERCHANTABILITY OR FITNESS FOR ANY PARTICULAR PURPOSE.

Some states do not allow limitations on how long an implied warranty lasts, so the above limitation may not apply to you. No warranties or representations at any time made by any representative of MYERS shall vary or expand the provisions hereof.

LIABILITY LIMITATION: IN NO EVENT SHALL MYERS BE LIABLE OR RESPONSIBLE FOR CONSEQUENTIAL, INCIDENTAL OR SPECIAL DAMAGES RESULTING FROM OR RELATED IN ANY MANNER TO ANY MYERS PRODUCT OR PARTS THEREOF.

Some states do not allow the exclusion or limitation of incidental or consequential damages, so the above limitation or exclusion may not apply to you.

This Warranty gives you specific legal rights and you may also have other rights which vary from state to state.

Direct all notices, etc. to: Warranty Service Department, F.E. Myers, 1101 Myers Parkway, Ashland, Ohio 44805.

**Myers**<sup>®</sup>

F.E. Myers, 1101 Myers Parkway, Ashland, Ohio 44805-1969  
419/289-1144, FAX: 419/289-6658, TLX: 948-7443