



ME40/ME40AG SERIES Submersible Sump, Effluent & Sewage Pumps

Installation and Service Manual

Automatic and manual models. Single phase power only — 115 or 230 volt.



DESCRIPTION AND APPLICATION

ME40

Myers ME40 Series Pumps are single seal units, automatic or manual, designed for use in effluent dosing. Septic Tank Effluent Pumping (S.T.E.P.) or normal sump and general dewatering applications where higher pressure is required. **DO NOT USE FOR RAW SEWAGE.**

When used in effluent dosing or S.T.E.P. applications, the pump must be installed in a separate tank or compartment at the discharge side of the septic tank. **NEVER INSTALL PUMP IN MAIN TANK WHERE SLUDGE COLLECTS.**

Impellers are enclosed two-vane type to handle 3/4" spherical solids and are made of engineered thermoplastic. All pumps have a 1-1/2" NPT discharge tapping. **NOTE: DO NOT OVERTIGHTEN DISCHARGE PIPE INTO PUMP PLASTIC DISCHARGE FITTING.**

General

These pumps are available in 115 volt or 230 volt, single phase, 4/10 HP motors. All units are single seal only, available in automatic or manual with either 10' or 20' power cords. All power cords have either 115 volt or 230 volt grounded plugs.

These pumps are NOT for use in swimming pools or fountains.

ME40AG

The ME40AG Series Pumps are single seal units designed for use in continuous run agricultural evaporative cooling applications. They will run continuously in elevated temperatures with clean sump water.

The wetted pump components are the same as already described for the ME40 series.

AIR LOCKING

A sump pump is said to be air locked if water traps air in the pump and it cannot get out, thus preventing the pump from operating.

The ME40/ME40AG pumps have a 1/16" air vent hole in the impeller chamber to let out trapped air. If this hole becomes plugged, the pump may air lock. As a secondary precaution a 1/8" hole should be drilled in the discharge pipe below the check valve. The check valve should be 12 to 18 inches above pump discharge. Do not put check valve directly into pump discharge opening.

PACKAGING

Each pump is packaged separately in a carton marked with a catalog number and Myers engineering number.

Catalog No.	Engineering No.	HP	V	Ph	Cord Lgth.	Type
ME40A-11	25300D000	4/10	115	1	10'	Auto
ME40M-11	25300D001	4/10	115	1	10'	Manual
ME40AC-11	25300D010	4/10	115	1	20'	Auto
ME40MC-11	25300D011	4/10	115	1	20'	Manual
ME40AC-21	25300D012	4/10	230	1	20'	Auto
ME40MC-21	25300D013	4/10	230	1	20'	Manual
ME40P-1	25300D900	4/10	115	1	10'	Auto
ME40PC-1	25300D901	4/10	115	1	20'	Auto
ME40P-2	25300D902	4/10	230	1	10'	Auto
ME40PC-2	25300D903	4/10	230	1	20'	Auto
ME40AG-11	27234D001	4/10	115	1	20'	Manual
ME40AG-21	27234D002	4/10	230	1	20'	Manual

LEVEL CONTROLS

All pumps must use sealed level control switches for automatic operation. All automatic pumps have built-in level control float switches. The power cord has a GROUND PIN that plugs into a grounded receptacle. The grounded receptacle cannot be used in the wet sump or basin due to DANGER of current leakage.

Manual pumps can be made automatic with MLC or MFLC controls with a series plug. Plug the MLC or MFLC witch cord series plug into a proper voltage GROUNDED RECEPTACLE. Then plug the pump cord plug into the back of the switch cord series plug. **NOTE:** The float control must be tethered a minimum 4" to pump or discharge pipe. Control must float free from pump and basin wall.

On all duplex units or simplex installations with additional options like high water alarm, the power cord plug must be cut off and wired into a control panel or into a sealed junction box if used in wet sump or basin. The AWS-1 control also acts as a sealed junction box for connecting power cord to pump cord.

NOTE: The ME40 sump/effluent pump can be easily changed from one style, automatic or manual, to the other by only interchanging the plug ends of the float control with the manual plug. The ball float must be tethered with a cable clamp, as shown. **DO NOT REMOVE THE MOTOR CAP.**

The ME40P pumps have a mechanical (mercury free) float switch with a 10' or 20' cord with a 115 volt or 230 volt piggyback plug with the switch mounted to the pump. Plug the switch cord plug into a proper voltage, properly grounded outlet and plug the power cord into the back of the switch cord and tape the cords to the discharge pipe every 12".

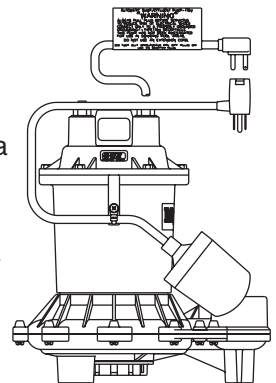

DESIGN OF PRESSURE SEWER SYSTEMS

Myers has available complete computer software for designing PRESSURE SEWER SYSTEMS. This gives pipe sizes to use and gives exact flow from any pump or group of pumps in the system when operating simultaneously. This design DISK for IBM® or COMPATIBLE computers is available to engineers on request.

MOTOR TYPE

The motors used in the ME40/ME40AG pumps are pressed into the cast iron housing and surrounded by dielectric oil for the greatest heat dissipation. The ME40 uses a shaded pole, 4/10 HP, 1550 RPM motor. The ME40AG uses a permanent split capacitor, 4/10 HP, 1625 RPM motor. Both units have Class A motor insulation, are available in single phase 115 or 230 volt with overload protection, and use a lower ball bearing - upper sleeve bearing. These pumps have no starting switches and do not require a control panel for simplex installation.

SAFETY WARNINGS

WARNING: Risk of electric shock. Pumps are supplied with a grounding conductor and grounding-type attachment plug on the power cord. To reduce the risk of electric shock, be certain that it is connected only to a properly grounded, grounding-type receptacle. **DO NOT** cut off ground pin or use an adapter fitting. **DO NOT** use an extension cord with this pump. Entire plug may be cut off if a control panel is used.

When wiring this pump, follow all local electrical and safety codes and ordinances as well as the most recent National Electric Code (NEC-ANSI/NFPA 70).

All pumps have a GROUND WIRE that is connected to the motor. This wire goes to the receptacle or control panel which must be connected to a good outside GROUND such as a metal water pipe or GROUND STAKE DRIVEN AT LEAST 8 feet into the ground.

UL AND CSA APPROVAL

All pumps have UL and CSA approval. Myers is a SSPMA certified pump member.

INSTALLATION

WARNING: Basin or tank must be vented in accordance with local plumbing codes. These pumps are not designed for and **CANNOT** be installed in locations classified as hazardous in accordance with the National Electric Code ANSI/NFPA 70.

CAUTION: Never enter pump chamber after sewage or effluent has been in basin. Sewage water can give off methane, hydrogen sulfide, and other gasses which are highly poisonous. For this reason, Myers recommends installing effluent pumps with a quick removal system. The quick removal system may be a union or Cam-lok® coupling if the pipe or discharge hose is within reach from the surface, or a rail system type quick disconnect on deeper installations. See installation drawings for suggested installation.

The dosing tank or pumping chamber must be constructed of corrosion resistant materials and must be capable of withstanding all anticipated internal and external loads. It also must not allow infiltration or exfiltration. The tank must have provisions for anti-buoyancy. Access holes or covers must be adequate size and be accessible from the surface to allow for installation and maintenance of the system. Access covers must be lockable or heavy enough to prevent easy access by unauthorized personnel. The pumping chamber holding capacity should be selected to allow for emergency conditions.

The discharge pipe must be the same size as the pump discharge, 1-1/2" or larger. In order to insure sufficient fluid velocity to prevent any residual solids from collecting in the discharge pipe, it is recommended that a minimum flow of 2' per second be maintained. (12 GPM through 1-1/2" pipe, 21 GPM through 2" pipe and 46 GPM through 3" pipe). It is recommended that PVC or equal pipe is used for corrosion resistance. A full flow (ball or gate) shut-off valve must be installed to prevent back flow of effluent if the pump must be removed for service. A check valve must be installed on pressure sewer systems and on other systems where conditions allow to prevent back flow and to reduce wear on the pump system.

A high water alarm must be installed on a separate circuit from the pump circuit. The alarm should have the ability to be tested for proper operation.

SCREEN

ME40AG pumps have a suction screen included in the packaging. To secure the screen in place use two screws (provided). Screen installation, maintenance, and cleaning is the responsibility of the pump owner.

BEFORE DISMANTLING PUMP FOR REPLACEMENT OF PARTS

Clean pump thoroughly. Knock off all scale and deposits. Submerge complete unit in Clorox solution for one hour before taking apart.

ME40 TYPICAL INSTALLATION



DIMENSIONS

[Dimensions in mm]

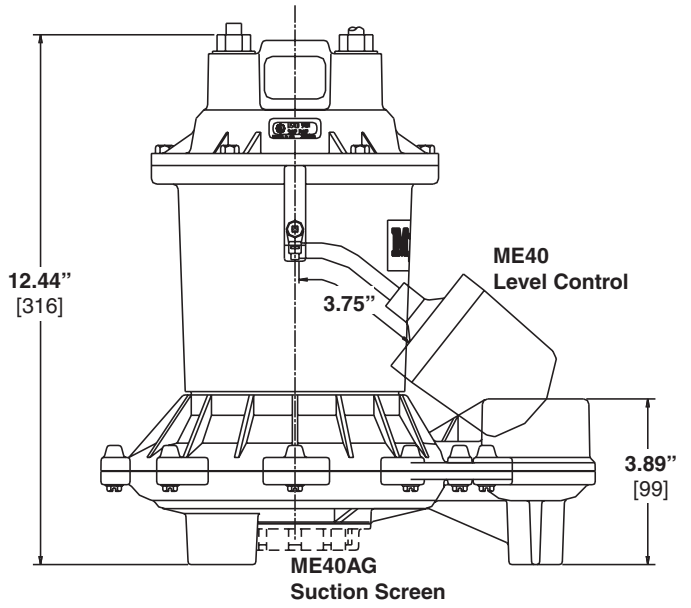
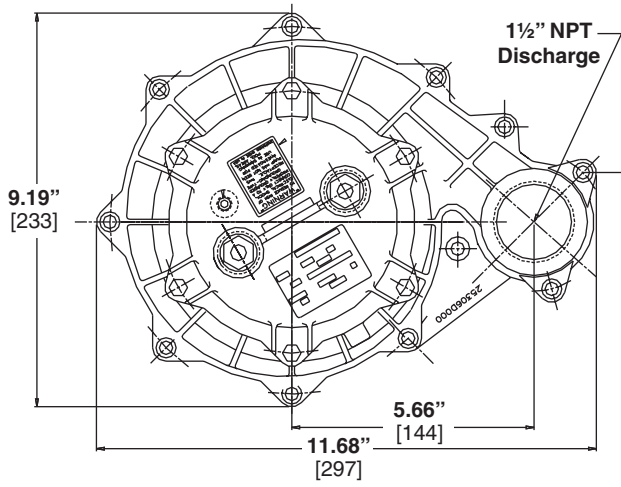

ME40 PERFORMANCE CURVE

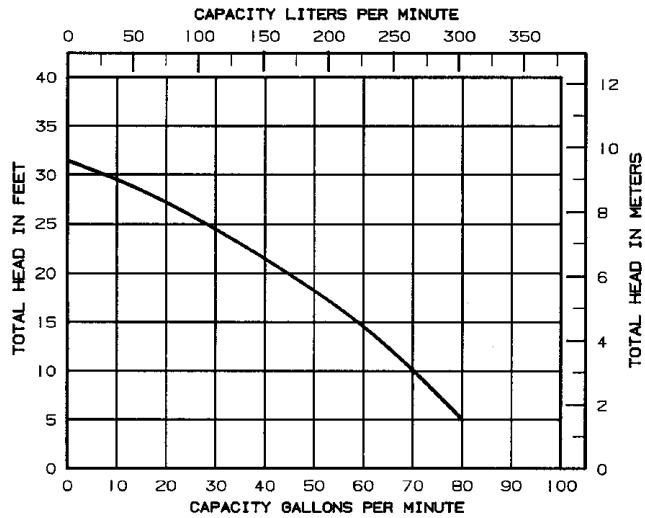

ME40AG PERFORMANCE CURVE

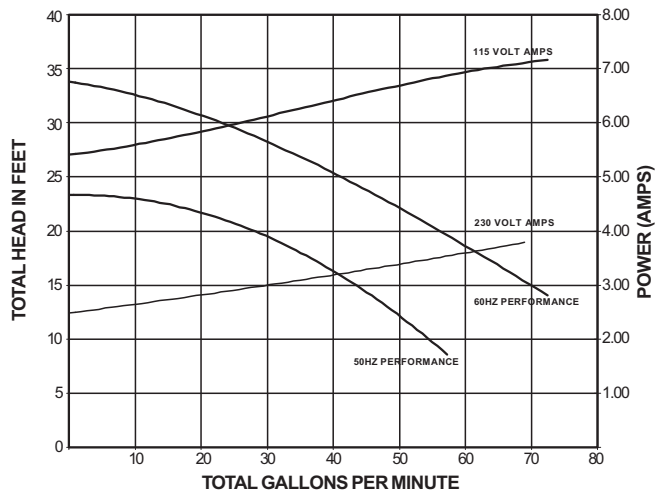

TROUBLE CHECK LIST

CONDITION	PROBABLE CAUSE
Pump does not run or start when water is up in tank.	<ol style="list-style-type: none"> 1. Check for blown fuse or tripped circuit breaker. 2. Check for defective level switch. 3. Where control panel is used be sure H-O-A switch is in the AUTO position. If it does not run, turn switch to the HAND position and if the pump runs then the trouble is in the automatic electrical system. have ELECTRICIAN make electrical checks. 4. Check for burned out motor. Occasionally lightning can damage a motor even with lightning protection. 5. Where plug-in cords are used be sure contact blades are clean and making good contact. DO NOT USE PLUG-IN CORDS INSIDE A SUMP OR WET WELL. 6. Level control ball or weight may be stuck on side of basin. Be sure it floats freely.
Pump runs but does not deliver flow	<ol style="list-style-type: none"> 1. Check for air lock. Start and stop pump several times, if this does not help it may be necessary to loosen a union in the discharge line to relieve air lock. 2. Check valve may be installed backwards. Check flow arrow on valve body. Check shut-off valve. It may be closed. 3. Check vertical elevation. It may be higher than pump can develop. (see pump curve) 4. Pump inlet may be plugged. Remove pump to check.

CAUTION: ALWAYS UNPLUG POWER CORDS OR TURN OFF ALL MAIN AND BRANCH CIRCUIT BREAKERS BEFORE DOING ANY WORK ON THE PUMP. If control panel is remote from pump, disconnect lead wires to motor so that no one can turn the circuit breaker back on.

TO REPLACE POWER CORD OR AUTOMATIC CONTROL FLOAT

1. Use a wrench to loosen and remove thermoplastic nut from the cap socket. Use your fingers to pull and wiggle the cord end connector from the socket.
2. To replace either the power cord or automatic control float, align the half circle notch on the cord end connector with the half circle key in the socket. Press the connector into the socket all the way.
3. Slide the thermoplastic washer onto the top of the cord end connector.
4. Screw the thermoplastic nut into the socket. Tighten the nut snugly, but do not over tighten. The nut may be tightened a little more after the connector has set over a period of time.
5. If replacing automatic control float be sure to tether float approximately 3-5/8".

FOR SHAFT SEAL ONLY REPLACEMENT

1. Remove the six screws from top thermoplastic cap and bump cap with plastic hammer to loosen.
2. Lay the cap back, do not disconnect wires from the cap. Pour all the oil from the pump. If the old seal failed there may be water in the oil and old oil should be discarded.
3. Remove the eleven machine screws holding the volute halves together. Separate lower half volute from the upper half by using a rubber hammer and/or prying lightly with a screwdriver.
4. Lay pump on its side. Place a flat screwdriver in the slot in the bottom of the shaft and turn the impeller counterclockwise to remove it from the shaft. A blow from a rubber hammer may be necessary to loosen the impeller.
5. Remove the rotating portion (carbon) of the seal with pliers. Pry out the stationary portion (ceramic) with a pair of slotted screwdrivers to remove from volute casing. Discard the old seal assembly parts. **NEVER USE OLD SEAL PARTS, REBUILD PUMP WITH ONLY NEW SEAL ASSEMBLY.**
6. Thoroughly clean the shaft and volute casing with a clean cloth. If the drained oil showed signs of water, then the motor should be air dried for several days to remove any remaining moisture.

7. Remove the seal from the package being careful not to touch the carbon or ceramic faces with fingers or anything dirty. Add a film of oil to the perimeter of the rubber cup holding the ceramic and insert into the motor housing. Use a push tool the same size as the ceramic face (a short piece of PVC pipe works well).
8. With a clean dry cloth, wipe away any smudging or oil from the seal faces. Add a film of new oil onto the motor shaft. With the carbon facing towards the ceramic, slide the rotating part onto the motor shaft. Push it on far enough to attach impeller.
9. Screw the impeller clockwise onto the shaft using a screwdriver to hold the shaft from turning and tighten impeller. Use Loctite or equal on shaft threads.
10. Place pump upright on top of lower volute half. Be sure mating parts are together and reassemble the eleven machine screws and tighten.
11. Check that the impeller turns freely.
12. Replace oil in motor housing using only Myers submersible transformer oil. The oil should be about 1/2" above the upper surface of the bearing plate.
13. Reinstall the top thermoplastic cap, making sure the o-ring is in position on the cap. Tighten the top six screws snug, but do not overtighten.
14. Plug pump into receptacle to test operation. Pump must run quiet and free of vibration.

TO REPLACE MOTOR STATOR HOUSING ASSEMBLY AND SEAL

1. Stator assembly includes housing, stator, rotor with shaft, thrust washers and metal bearing plate. (See repair parts list)
2. Remove the six screws from top thermoplastic cap and bump cap with plastic hammer to loosen.
3. Disconnect the four motor lead wires from the cap pin terminals and remove cap. Pour all the oil from the pump.
4. Remove the eleven machine screws holding the volute halves together. Separate lower half volute from the upper half by using a rubber hammer and/or prying lightly with a screwdriver.

5. Lay pump on its side. Place a flat screwdriver in the slot in the bottom of the shaft and turn the impeller counterclockwise to remove it from the shaft. A blow from a rubber hammer may be necessary to loosen the impeller. Discard old seal part.
6. Remove the four flat head screws holding the upper half of volute to housing. Note position of discharge in relation to switch clamp.
7. To assemble the new ceramic seal seat into your new stator housing assembly, clean the seat cavity thoroughly and follow Steps 7 & 8 "For Shaft Seal Only Replacement". NEVER USE OLD SEAL PARTS. USE ONLY COMPLETELY NEW SEALS.
8. Assemble the upper half of the volute to housing with the four flat head screws. Position discharge the same as before in relation to switch clamp.
9. Make sure the shaft surface is clean and lightly oiled. Press by hand the rotating half of the shaft seal onto the shaft. Be sure the rotating carbon washer is positioned adjacent to the ceramic seat.
10. Screw the impeller clockwise onto the shaft using a screwdriver to hold the shaft from turning and tighten impeller. Use Loctite or equal on shaft threads.
11. Place pump upright on top of lower volute half. Be sure mating parts are together and reassemble the eleven machine screws and tighten.
12. Check that the impeller turns freely.
13. Guide the four motor wires up through a common hole in the bearing plate and place the protective plastic tube over the four motor wires.
14. Position the o-ring into cap and reconnect the four motor wires as shown in wiring diagram. The two green ground wires connect to the pins nearest the 'G' marked on the cap.
15. Put oil in the motor housing using only Myers submersible transformer oil. The oil should be about 1/2" above the surface of the bearing plate.
16. Reinstall the top thermoplastic cap, making sure the o-ring is in position on the cap. Tighten the top six screws snug, but do not overtighten.
17. Be sure the 1/8" NPT pipe plug is in the top cap.
18. Plug pump into receptacle to test operation. Pump must run quiet and free of vibration.

NOTE: When replacing top cap with a new one, be sure the jumper wire and pipe plug are in place. See wiring diagram. Tether level control to motor housing with float extended 3-5/8" to 4".

WIRING DIAGRAM

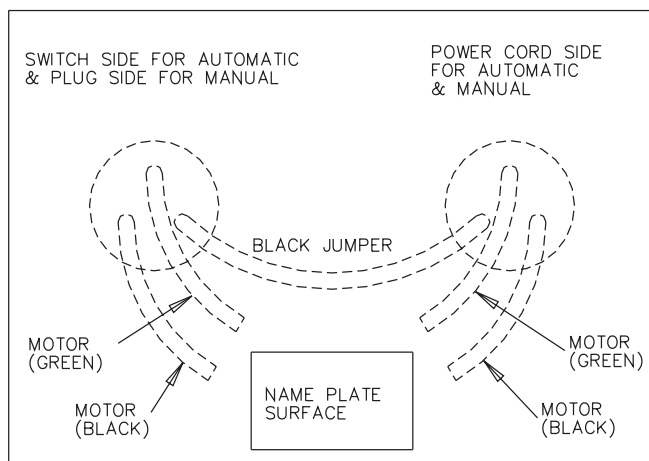

MOTOR REISTANCE CHART

Model	HP	Speed	V	Ph	Winding Resistance in Ohms	Max. Amps	Locked Rotor Amps
ME40	4/10	1550	115	1	1.2	12.0	16.0
ME40	4/10	1550	230	1	4.3	6.0	8.2
ME40AG	4/10	1650	115	1	2.0	8.0	17.6
ME40AG	4/10	1650	230	1	9.1	4.0	8.8

TYPICAL SECTION DRAWING FOR ME40 SERIES Shaded Pole Motor

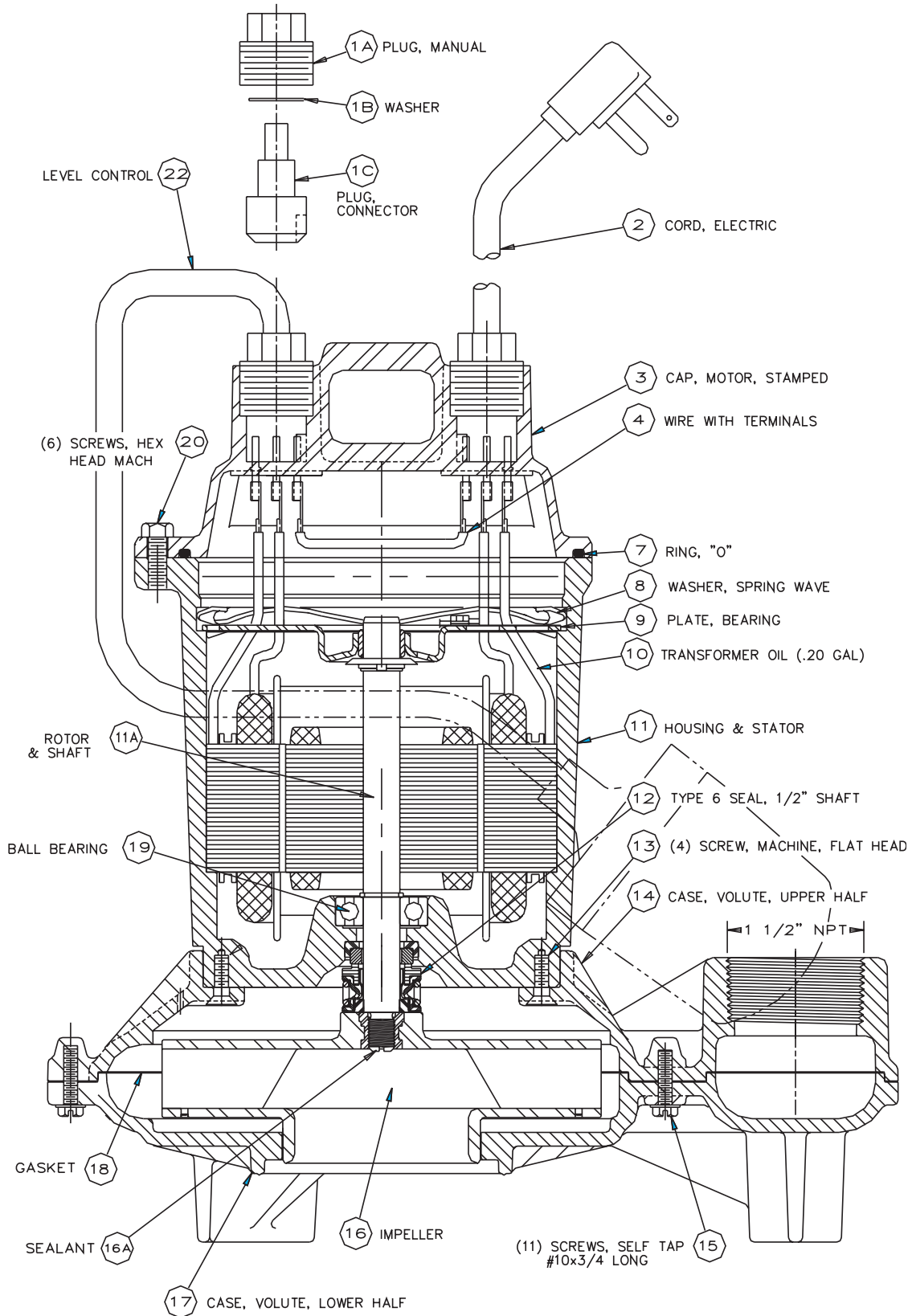

TYPICAL SECTION DRAWING FOR ME40AG SERIES PSC Motor

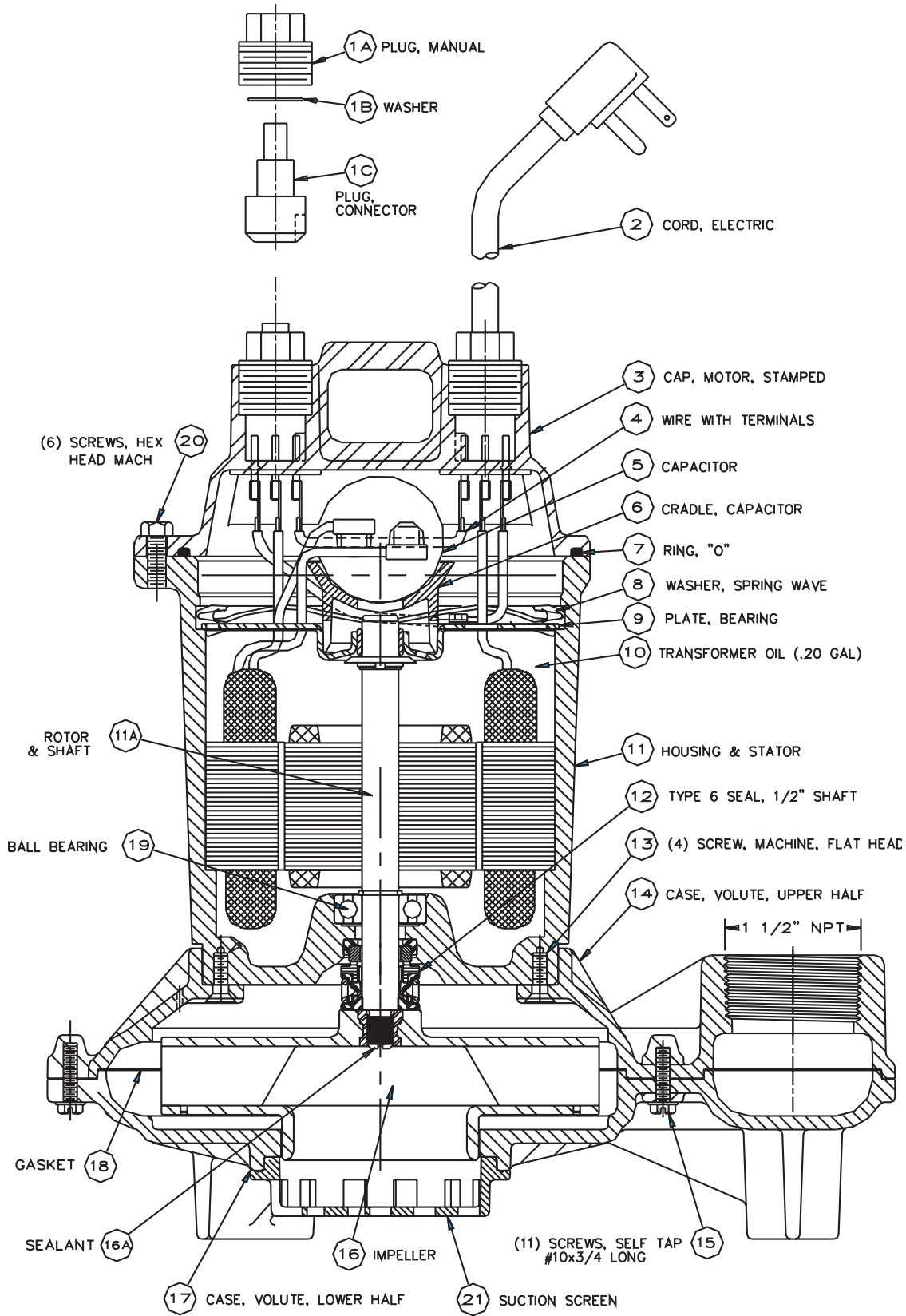

PARTS LIST ME40/ME40AG

Ref. No.	Description	No. Req'd	Part Numbers
1A	Plug, nut (manual only)	1	24448A000
1B	Washer (manual only)	1	05030A213
1C	Plug, connector (manual only)	1	24449A000
2	Cord, electric	1	See Chart
3	Cap, motor (not stamped)	1	24431C000
4	Wire with terminals	1	09859A800
5	Capacitor (115 volt)	1	26446A000
5	Capacitor (230 volt)	1	23290A000
6	Cradle, capacitor (230 volt)	1	26298B000
7	O-Ring, 5-1/2 x 5-1/4 x 1/8	1	05876A146
8	Washer, spring wave	1	19331A011
9	Plate, bearing	1	24661B000
10	Oil, transformer (1 gal.)	.2 gal.	11009A008
11	Housing, with rotor & stator	1	See Chart
	Stator only	1	See Chart
	Rotor & shaft, ME40	1	25309A000
	Rotor & shaft, ME40AG	1	26166B000
	Housing only	1	27313C000

Ref. No.	Description	No. Req'd	Part Numbers
12	Seal, shaft	1	21607A015
13	Screw, machine, flat head	4	07597A030
14	Case, volute, upper half	1	25306D000
15	Screws, self tap #10 x 3/4	11	05910A012
16	Impeller	1	25301B900
16A	Sealant, Loctite 242	1	14550A001
17	Case, volute, lower half	1	25307D001
18	Gasket, Vellumoid	1	25328C000
19	Ball bearing	1	000650241
20	Screws, hex head mach.	6	18475A003
21	Suction screen	1	25307A015
22	Level control	1	See Chart

CHART

Pump Catalog Number	Pump Engineering Numbers	Pump Type	② Cord, Electric	Cord Length	⑪ Housing w/Rotor & Stator	Stator Only	⑫ Level Control
ME40A-11	25300D000	Automatic	21628B017	10'	27313C010	21599B022	25798A550
ME40M-11	25300D001	Manual	21628B027	10'	27313C010	21599B022	---
ME40AC-11	25300D010	Automatic	21628B018	20'	27313C010	21599B022	25798A550
ME40MC-11	25300D011	Manual	21628B018	20'	27313C010	21599B022	---
ME40AC-21	25300D012	Automatic	21628B019	20'	27313C011	21599B023	25798A550
ME40MC-21	25300D013	Manual	21628B019	20'	27313C011	21599B023	---
ME40P-1	25300D900	Automatic	21628B041	10'	27313C010	21599B022	21813B130
ME40PC-1	25300D901	Automatic	21628B018	20'	27313C010	21599B022	21813B131
ME40PC-2	25300D903	Automatic	21628B019	20'	27313C011	21599B023	21813B133
ME40AG-11	27234D001	Manual	21628B044	20'	27313C012	26165B000	---
ME40AG-21	27234D002	Manual	21628B043	20'	27313C013	26165B001	---

LIMITED WARRANTY

F.E. MYERS warrants to the original consumer purchaser ("Purchaser" or "You") of the products listed below, that they will be free from defects in material and workmanship for the Warranty Period shown below.

Product	Warranty Period
Sump/Sewage/Effluent Products	24 months from date of manufacture
Fibrewound Tanks	5 years from date of original installation
Steel Pressure Tanks	5 years from date of original installation
Jet pumps, small centrifugal pumps, submersible pumps and related accessories	<i>whichever occurs first:</i> 12 months from date of original installation, or 18 months from date of manufacture

Our warranty will not apply to any product that, in our sole judgement, has been subject to negligence, misapplication, improper installation, or improper maintenance. Without limiting the foregoing, operating a three phase motor with single phase power through a phase converter will void the warranty. Note also that three phase motors must be protected by three-leg, ambient compensated, extra-quick trip overload relays of the recommended size or the warranty is void.

Your only remedy, and F.E. MYERS's only duty, is that F.E. MYERS repair or replace defective products (at F.E. MYERS's choice). You must pay all labor and shipping charges associated with this warranty and must request warranty service through the installing dealer as soon as a problem is discovered. No request for service will be accepted if received after the Warranty Period has expired. This warranty is not transferable.

F.E. MYERS SHALL NOT BE LIABLE FOR ANY CONSEQUENTIAL, INCIDENTAL, OR CONTINGENT DAMAGES WHATSOEVER.

THE FOREGOING WARRANTIES ARE EXCLUSIVE AND IN LIEU OF ALL OTHER EXPRESS AND IMPLIED WARRANTIES, INCLUDING BUT NOT LIMITED TO THE IMPLIED WARRANTIES OF MERCHANTABILITY AND FITNESS FOR A PARTICULAR PURPOSE. THE FOREGOING WARRANTIES SHALL NOT EXTEND BEYOND THE DURATION EXPRESSLY PROVIDED HEREIN.

Some states do not allow the exclusion or limitation of incidental or consequential damages or limitations on the duration of an implied warranty, so the above limitations or exclusions may not apply to You. This warranty gives You specific legal rights and You may also have other rights which vary from state to state.

This warranty supersedes and replaces all previous warranty publications.

F.E. MYERS
1101 Myers Parkway, Ashland, OH 44805-1989
Phone: 888-987-8677 • Fax: 888-840-7867 • www.femyers.com

Myers®

F. E. Myers, 1101 Myers Parkway, Ashland, OH 44805-1969
888-987-8677, FAX: 888-840-7867, www.femyers.com

Myers (Canada), 269 Trillium Drive, Kitchener, Ontario N2G 4W5
519/748-5470, FAX: 519/748-2553