

MBSP-PLUS SERIES

SPECIFICATIONS

| | | |
|-------------------------|---|------------|
| Applications | Emergency Dewatering | |
| Capacities | 2700 GPH | 10,220 LPH |
| Shut-off Head | 18' | |
| Liquids Handling | sump drain water | |
| Continuous Liquid Temp. | up to 77°F | up to 25°C |
| Motor | 12V DC, 18A | |
| Charger | Fully automatic, computerized monitoring, control and alarm system; input - 115V AC, 60Hz; output - 12V AC, 8A (5 stages) | |
| Check Valve | included | |
| Housing | thermoplastic | |

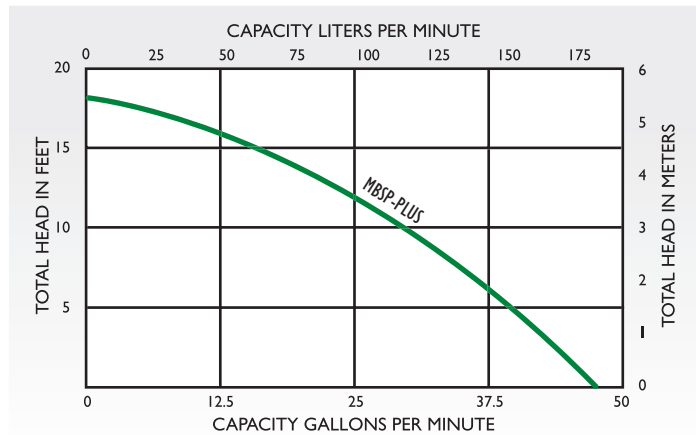

FEATURES

- 2700 GPH (10,220 LPH), 8A 5-stage charging system
- Thermoplastic pump with steel case charger enclosure
- 1-1/4" (32 mm) NPT threaded discharge; adapts to 1-1/4" (32 mm) and 1-1/2" (38 mm) NPT
- High volume ideal for active sump pits
- 8A multi-stage charging system (UL/CUL approved) with steel enclosure provides the strongest battery charge
- Plug-in style connectors for quick and easy installation
- Audio and visual alarms keep you informed of status at all times
- Check valve and battery case included
- Fits most new and existing sump pits



MBSP-PLUS SERIES

TYPICAL INSTALLATION

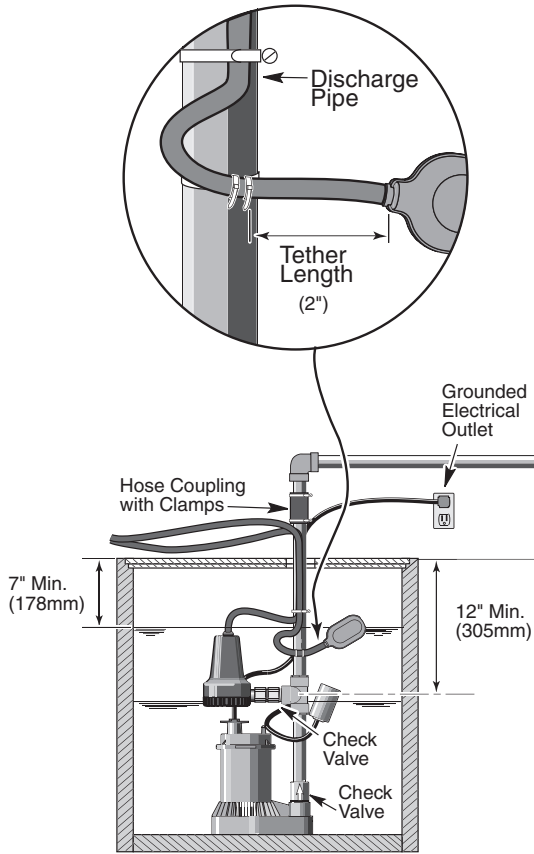

Carton Dimensions:
16-3/4" x 20-1/8" x 9-1/2"

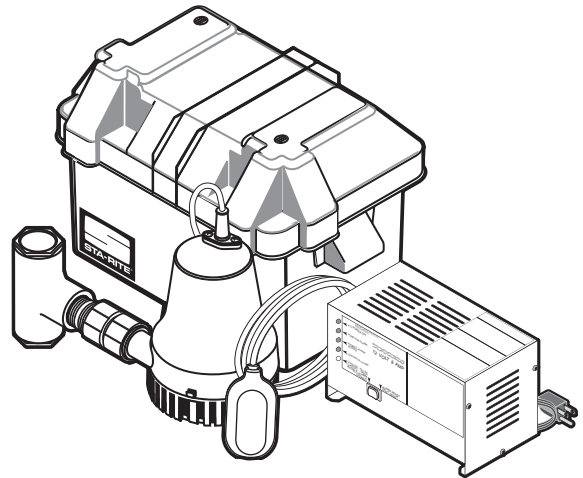

Dimensions (in inches) are for estimating purposes only.