

PRE-PLUMBED SUMP BASIN PACKAGE

PSB1822

The Myers® Pre-plumbed Sump Basin Package is a rugged, high-quality system ideal for basement sumps and dewatering. The basin features an approved radon-proof design. The unit comes field-ready with a 1-1/2" NPT threaded discharge flange and a 2" NPT vent flange (adaptable to 3") and includes a 1-1/2" sump check valve.



APPLICATIONS

Basement sumps, dewatering, new or existing installations

SPECIFICATIONS

- Capacities – 32 GPM (121 LPM)
- Shut-off Head – 22' (6.7 m)
- Operation – On: 9.5" (241 mm)
Off: 2.5" (63 mm)
- Solids Handling – 1/4" (6.35 mm)
- Liquids Handling – Drain water
- Intermittent Liquid Temperature – Up to 140°F (60°C)
- Motor/Electrical Data – 1/4 HP, 115V, 1Ø, 60Hz
- Shaft Seal – Carbon and ceramic
- Housing – Cast iron
- Power Cord – 10', SJTW, SJTW-A
- Discharge, NPT – 1-1/2" (38 mm)
- Basin Size – 18" x 22" structural foam; 20-gallon capacity

FEATURES

Fully Assembled

The fully assembled system includes: pump, basin, sealed cover, internal basin discharge pipe and check valve

Stackable Design

Allows for compact inventory and shipping

Heavy-duty SP25 Pump

- Long-life carbon/ceramic seal protects motor against leakage
- Features an energy-saving, permanent split capacitor run motor
- Internal heat sensor prevents overheating and includes automatic reset
- Recessed impeller designed to resist clogging

BASIN

- 18" x 22" corrosion-resistant structural foam construction
- 20-gallon capacity
- Hub adapter: 4" snap-in type with stainless steel clamp – fits 4" DWV SCH. 40 plastic pipe
- Flanges: 1-1/2" NPT threaded discharge and 2" NPT vent flange (converts to 3"); includes gas-tight cord grommet
- Check valve fits 1-1/2" black, galvanized, and DWV SCH. 40 pipe

BASIN COVER

Gas-tight, single-piece design with seal; structural foam construction

ORDERING INFORMATION

Catalog Number	HP	Volts	Phase/Cycles	Amps	Discharge Size	Switch Type	Cord Length	Approx. Wt. Lbs.
PSB1822	1/4	115	1/60	6.5	1-1/2"	Tethered Automatic	10'	27

In order to provide the best products possible, specifications are subject to change. Myers® is a registered trademark of Pentair Water.

PRE-PLUMBED SUMP BASIN PACKAGE

DIMENSIONS

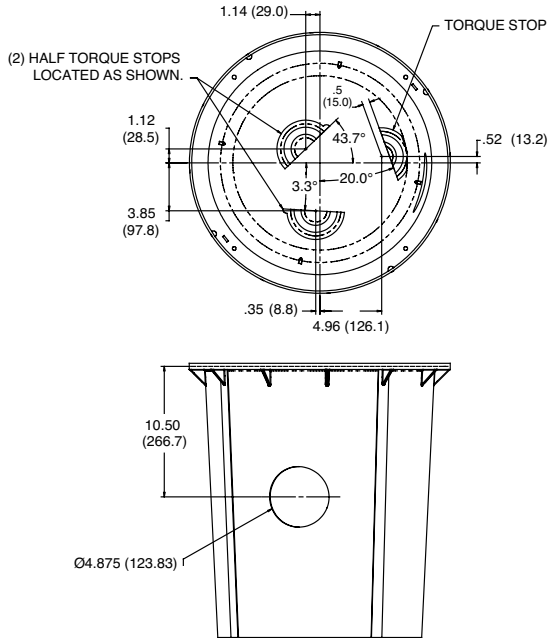

SECTIONAL VIEW

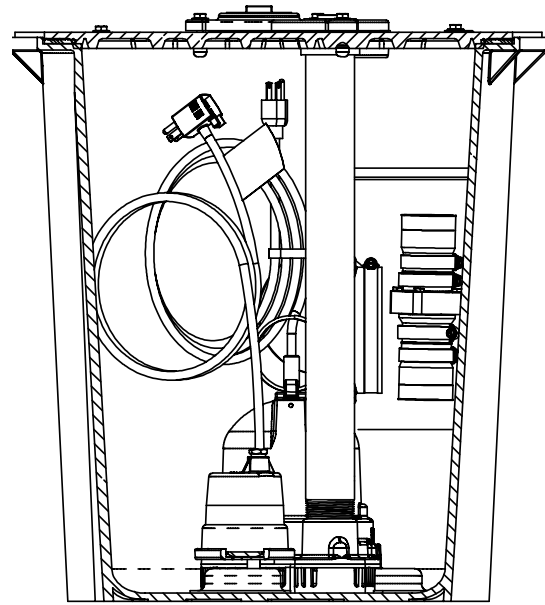

PUMP PERFORMANCE

