



ITT

BRGSPUMP

Food Processing

Goulds Pumps

G&L Series GSP

Sanitary Pumps



Goulds Pumps is a brand of ITT Corporation.

www.goulds.com

Engineered for life

Applications

- The G&L Series GSP pumps are mainly used in the food, beverage, cosmetic, agricultural and fine chemical industries, where clean or slightly charged, polluted, abrasive or viscous liquids are to be transferred.

Some actual applications are: milk, egg, soya, beer, wort, wine, fruit juices, soft drinks, alcohol, yeast, starch, vegetable and ethereal oils, sugar solutions, brine, blood, light chemicals, solvents, detergents, demineralized water and CIP-solutions.

Perfectly Cleanable

Material: 316L Stainless Steel

- Pump casings: thick cold-rolled plate: 100% non-porous and extremely smooth.
- Impellers: Investment cast, machined and polished.

Finish: Electrolytically polished

All stainless steel parts are degreased, pickled, passivated and electropolished. This leads to:

- Extremely low microroughness resulting in a substantially increased resistance to the adhesion of products. The result: excellent ease of cleaning and the ultimate bacteriological purity.
- A highly increased corrosion resistance due to the higher percentage of the noble materials chromium and nickel at the surface and due to the total absence of tension concentrations, caused by mechanical polishing or glass bead blasting.

CIP-Cleanable

- The large seal cavity of the GSP Series pump is designed in such a way that there is enough turbulence to clean the inner seal. EHEDG-testing has confirmed this.

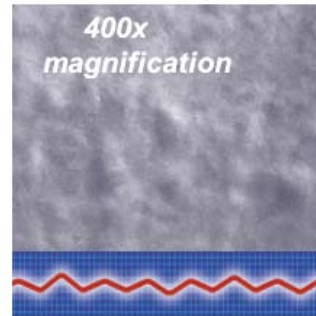
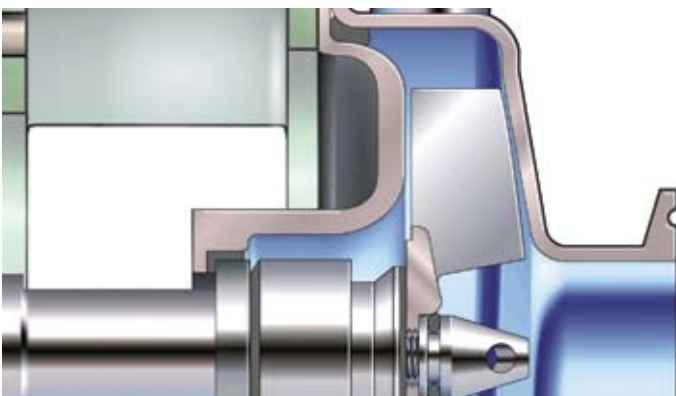

Electro – polished

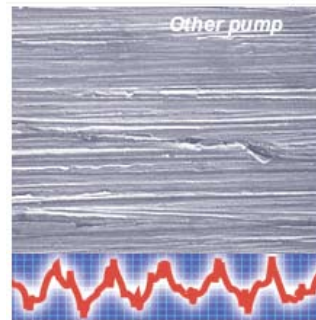

Mechanical polishing 240 grit

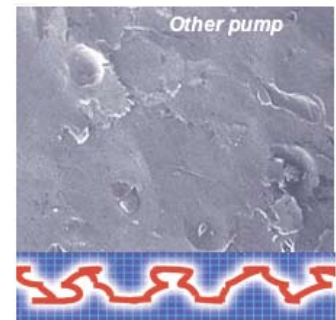

Glass bead blasted

Internal Bellows Seal

- The impeller and the shaft are in one piece, which avoids the pumped product making contact with the shaft (no doweled or screwed machined surfaces that can be bacteria traps).
- The open seal chamber provides internal self-flushing.
- The internal design assures seal retention during water hammer.
- The internal seal prevents product build-up on the shaft which could cause bacterial growth, pitting corrosion and shaft wear. Ideal for start-stop duties.

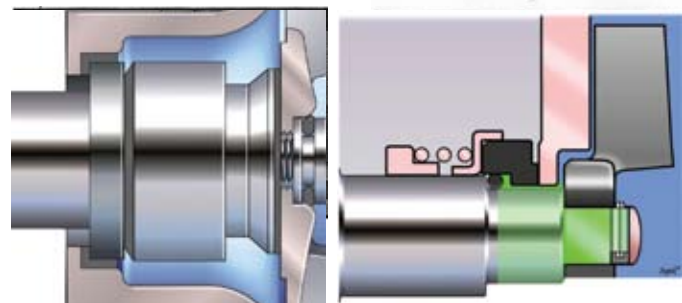

Goulds Pumps GSP

Other Pump

Performance Curves

End Suction Pumps – Performance curves at 3500 RPM

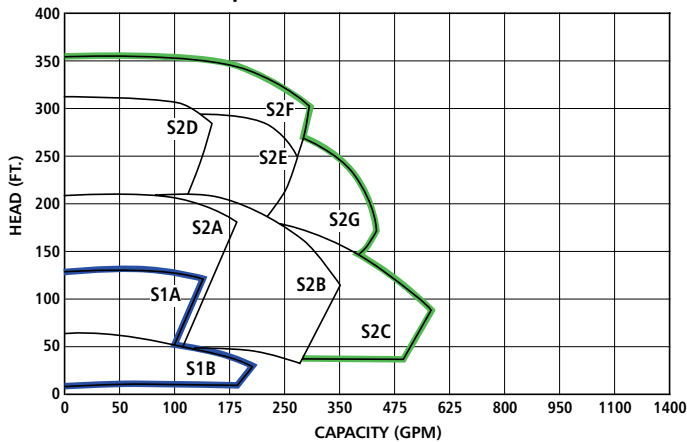

End Suction Pumps – Performance curves at 1750 RPM

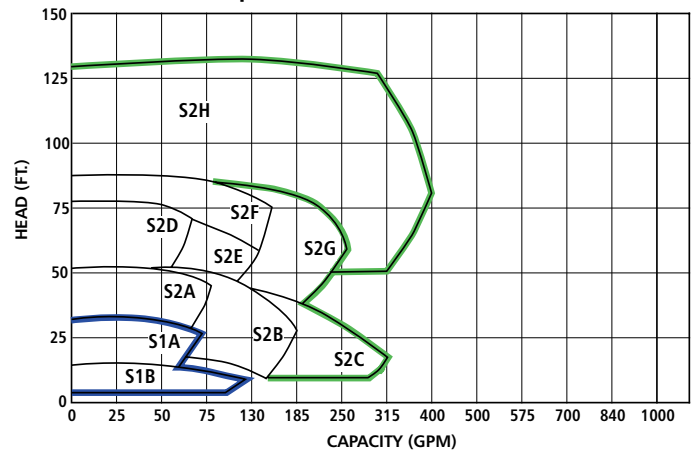

Performance to Match your Need

Optimum Efficiency

- Ten casing sizes in two ranges are available to match pump performance to hydraulic requirement. This provides the best system efficiency and lowest energy use.
- Volute casing provides 70% average best efficiency for lower operating costs.

Gentle Product handling

- Volute type casing leading to higher efficiency, less turbulence and hence reduced risk of product damage.
- Open impeller



S1 Series

- A compact close-coupled 316L pump mounted to a NEMA 56J frame motor.
- Two sizes are available from ½ to 5 HP.
- Flows to 180 GPM, heads to 130 ft.
- Non-clogging open impeller.
- Easy to clean internal seal design.
- 3A approved to standard 02-10.
- High efficiency volute casing design.

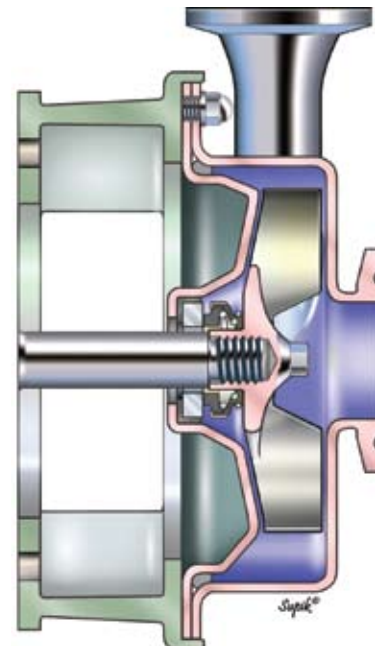

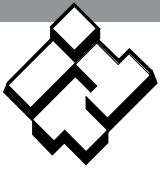

ITT

Food Processing

S2 Series

- A compact close-coupled 316L pump mounted to a NEMA JM frame motor.
- Eight sizes are available from 3–25 HP
- Flows to 575 GPM, heads to 350 feet
- Easy to clean internal seal design
- 3-A approved to standard 02-10
- High efficiency volute casing design
- Non-clogging open impeller

Open Impeller

- Low NPSH-values
- Excellent air handling
- non-clogging
- No axial stress on the motor bearings
- Low pressure in seal cavity: extended seal life
- 3A and EHEDG approved

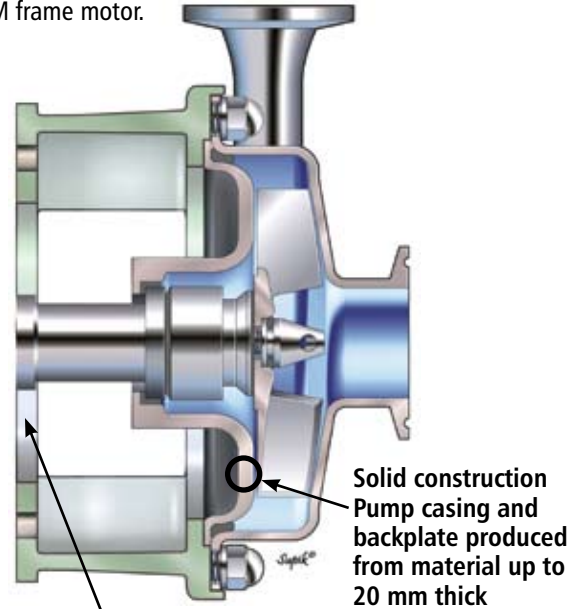
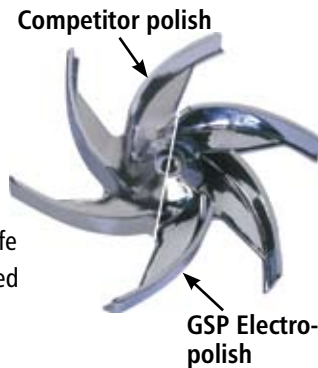

- Stainless steel adapter with drain openings
- Direct mount to NEMA JM Frame Motors
 - Easy drainage of any leakage

External Cleanability

- Electro-polished external pump surfaces.
- Pump stand features polished edges to assure there are no crevices where bacteria could grow.
- Optional motor housing permits spray wash with use of commonly available drip proof or fan cooled motors.
- Mounting feet for either permanent mounting or movement to different use areas designed to comply with 3-A standard 88-00.



Goulds Pumps and the ITT Engineered Blocks Symbol are registered trademarks and tradenames of ITT Corporation.

SPECIFICATIONS ARE SUBJECT TO CHANGE WITHOUT NOTICE.

BRGSPUMP June, 2008

© 2008 ITT Corporation

Engineered for life