



ITT

BHSJ

Residential Water Systems

Goulds Pumps

HSJ Multi-Stage Convertible Jet Pumps - 60 Hz



Basic Convertible Pump

FEATURES

- **High Capacity and Pressure:** Specifically designed to deliver high capacities at greater pressures.
- **Stainless Steel Pump Shaft:** Hex design provides positive drive for impellers and eliminates clearance adjustments.
- **Easy to Service:** Can be taken apart for service by removing four bolts.
- **Corrosion Resistant:** Glass filled thermo-plastic impellers. Stainless steel wear rings and coverplates. Electrocoat paint process applied inside and out and then baked on.
- **Powered for Continuous Operation:** Pump is designed for continuous operation. All ratings are within the motor manufacturer's recommended working limits.
- **Convertible:** Designed for use on shallow or deep well applications using appropriate Goulds Pumps fittings. See the performance charts on the following pages for fitting order numbers.

 **GOULDS PUMPS**

Goulds Pumps is a brand of ITT Corporation.

www.goulds.com

Engineered for life

Goulds Pumps

HSJ Multi-Stage Convertible Jet Pumps

APPLICATIONS

Specifically designed for:

- Homes, Farms, Cottages, Booster service

SPECIFICATIONS

Pump:

- Pipe connections:
1 1/4" NPT suction, 1" NPT discharge,
1" NPT drive (pressure).
- Pressure switch:
3/4 – 1 1/2 HP, AS4; 2 HP, AS10,
both preset (30-50 PSI).

Motor:

- NEMA standard.
- 3/4-1 1/2 HP – 115/230 V
- 2 HP – 230 V only
- 60 Hz, capacitor start.
- Single phase, 3500 RPM.
- Built-in overload with automatic reset.
- Stainless steel shaft.
- Rotation: clockwise when viewed from motor end.

Maximum temperature: 140°F.

SYSTEM COMPONENTS

- **Basic Pump Unit:** Includes pump, motor, pressure switch, tubing, fittings, pressure gauge and bushing.
- **Shallow Well Package:** Includes adapter, nozzle, venturi, bolts, gasket and pipe plugs.
- **Deep Well Jet Assembly Package:** Twin Pipe includes: jet body, nozzle, venturi and foot valve. Packer includes: jet body with built-in check valve, nozzle and venturi.

Additional Accessories Required:

- Packer System – well casing adapter AWJ2 (2") and turned coupling 64655 or AWCJ3 (3").
- For Deep Well Systems – a pressure control valve such as an AV22KIT or AV22 plus a JDW tubing kit.

AGENCY LISTINGS



Canadian Standards Association



Underwriters Laboratories[®]

Goulds Pumps is ISO 9001 Registered.

MODEL INFORMATION

CSA Listed Order No.	U.L. Listed (Indoor use) ^① Order No.	HP	Stages
HSJ07N	HSJ07NUL	3/4	2
HSJ10N	HSJ10NUL	1	2
HSJ15N	HSJ15NUL	1 1/2	3
HSJ20N	HSJ20NUL	2	3



AV22

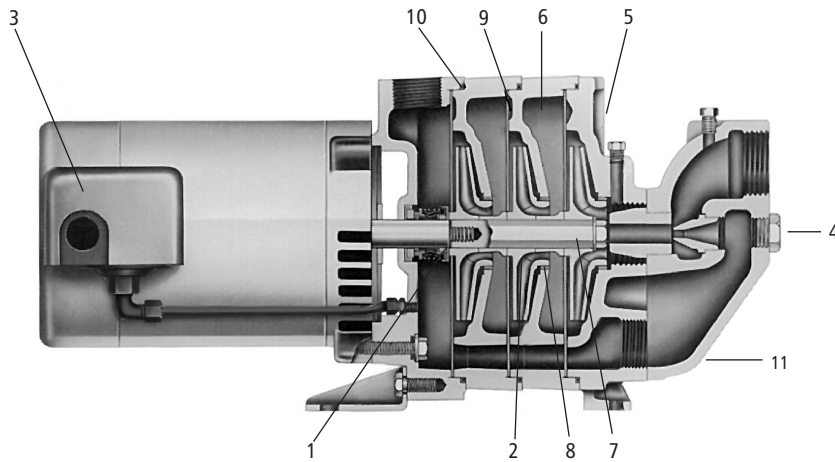

Shallow Well Model

COMPONENTS

Item No.	Description
1	Mechanical seal
2	Impeller
3	Pressure switch
4	Nozzle clean-out plug
5	Casing
6	Intermediate stage
7	Hex shaft extension
8	Wear ring
9	Cover plate
10	O-rings
11	Shallow Well Adapter

DIMENSIONS AND WEIGHTS

HP/Model	¾-HSJ07N	1-HSJ10N	1½-HSJ15N	2-HSJ20N
Weight	53	58	72	75
Length ^①	15	16	17	19
Width	8	8	8	8
Height	9	9	9	9

(All dimensions are in inches and weights in lbs. Do not use for construction purposes.)

① Add 4" for shallow well adapter.

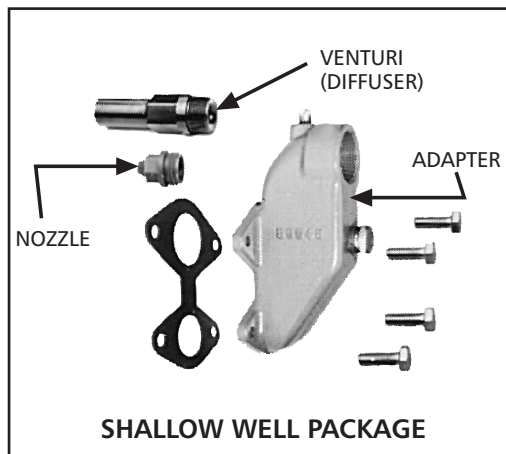

Goulds Pumps

HSJ Multi-Stage Convertible Jet Pumps

PERFORMANCE RATINGS – SHALLOW WELL SYSTEM

HP/Model	¾ HP – HSJ07N					1 HP – HSJ10N					1½ HP – HSJ15N					2 HP – HSJ20N								
Shallow Well Package	FHSJ07					FHSJ10					FHSJ15					FHSJ20								
Adapter	4K62										4K62													
Nozzle	AN012					AN012					AN012					AN012								
Venturi	AD3432					AD3437					AD3439					AD3448								
	Discharge Pressure – PSI										Discharge Pressure – PSI													
Total Suction Lift (feet)	30	40	50	60	Max. Shut off (PSI)	30	40	50	60	Max. Shut off (PSI)	30	40	50	60	70	80	Max. Shut off (PSI)	30	40	50	60	70	80	Max. Shut off (PSI)
	Gallons per minute					Gallons per minute					Gallons per minute					Gallons per minute								
5'	18.5	18.3	14.6	8.0	76	22.8	22.7	19.8	12.2	79	22.8	22.8	22.8	21.7	17.0	11.2	104	28.2	28.0	25.8	22.7	21.2	16.2	105
10'	15.9	15.8	12.7	6.7	74	20.7	20.3	17.5	10.3	77	20.7	20.7	20.7	20.0	16.3	9.0	102	24.8	24.7	24.2	23.3	18.7	13.7	103
15'	13.8	13.8	11.0	5.6	71	18.0	17.8	15.2	9.2	74	18.0	18.0	18.0	17.7	14.2	–	99	21.3	21.3	20.8	20.7	18.7	13.7	101
20'	13.8	11.3	9.2	–	68	14.5	14.3	12.8	–	71	15.0	15.0	15.0	15.0	12.0	–	97	18.0	17.7	17.5	17.0	16.2	10.8	98
25'	8.6	8.6	5.7	–	65	11.5	11.4	8.3	–	68	11.2	11.2	11.2	11.0	–	–	95	12.3	12.0	11.9	11.7	10.5	–	95

Deep Well Twin Pipe System

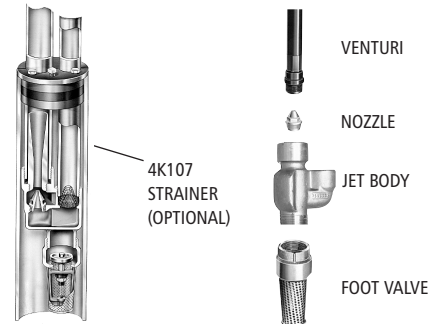

PERFORMANCE RATINGS — TWIN PIPE SYSTEMS – 4" WELL

HP/Model		¾ HP – HSJ07N			1 HP – HSJ10N			1½ HP – HSJ15N			2 HP – HSJ20N		
Jet Assembly Package (1)		FT4-48	FT4-47	FT4-06	FT4-47	FT4-24	FT4-08	FT4-45	FT4-30	FT4-29	FT4-45	FT4-30	FT4-29
Pressure Suction	Pipe Size (in.)	1"											
		1¼"											
Nozzle		AN012	AN013	AN014	AN013	AN015		AN013					
Venturi (Diffuser)		AD727	AD724	AD720	AD724		AD720	AD726	AD722	AD719	AD726	AD722	AD719
Pressure Control Valve Setting (PSI)		37	40			43		62	65	67	76	78	80
Depth to Jet Assembly (based on submergence of 5 feet)	Feet	Gallons Per Minute (GPM) 30-50 Pressure Switch Setting											
	30	15.1			16.0			13.0			13.0		
	40	13.5			15.2			13.0			13.0		
	50	11.8			14.7			13.0			13.0		
	60	10.7			13.7			12.8			12.8		
	70	8.5	9.0		11.7	11.7		12.2			12.8		
	80		7.5			10.5		10.6			12.0		
	90		6.2	6.2		9.0		9.2	9.3		11.3		
	100			5.8		7.5			9.0		9.5	9.5	
	110			5.0		6.3	6.0		8.0			9.4	
	120			4.6			5.0		7.0			8.5	
	130			4.0			4.3		6.2	5.8		7.7	
	140						4.0			5.6		6.8	
	150						3.5			5.2		6.0	5.7
	160									4.7			5.5
	170									4.2			5.3
	180									3.7			5.0
190									3.2			4.5	
200												3.8	

(1) Jet assembly package includes jet body (AT4), venturi, nozzle and foot valve.

NOTE: An offset of 50 feet will result in a decrease of about 25% from ratings as shown.

Goulds Pumps

HSJ Multi-Stage Convertible Jet Pumps

Deep Well Packer System



PERFORMANCE RATINGS — PACKER SYSTEM

HP/Model	¾ HP – HSJ07N						1 HP – HSJ10N						1½ HP – HSJ15N						2 HP – HSJ20N					
Well Casing (in.)	2 ①		3				2 ①		3				2 ①		3				2 ①		3			
Suction Pipe Size (in.)	1¼		1½				1¼		1½				1¼		1½				1¼		1½			
Jet Assembly Package (1)	FP2-51	FP2-50	FP2-06	FP3-40	FP3-42	FP2-50	FP2-07	FP2-08	FP3-40	FP3-49	FP2-49	FP2-30	FP2-29	FP3-47	FP3-46	FP3-34	FP2-49	FP2-30	FP2-29	FP3-47	FP3-46	FP3-34		
Jet Body (Only)	AP2			AP3			AP2			AP3			AP2			AP3			AP2			AP3		
Nozzle	AN012	AN013	AN014	AN013	AN014	AN013	AN014	AN015	AN013	AN015	AN013													
Venturi	AD727	AD724	AD720	AD724	AD722	AD724	AD720	AD724	AD723	AD726	AD722	AD719	AD727	AD722	AD719	AD726	AD722	AD719	AD727	AD722	AD719			
Pressure Control Valve Setting (PSI)	40		36	40		45		40	43	62	65	67	62	64	66	76	78	80	75	78	80			
Depth to Jet Assembly (based on submergence of 5 feet)	Feet	Gallons Per Minute (GPM) 30-50 Pressure Switch Setting																						
	30	14.9			15.3		15.8			16.3		13.0			14.7			13.0			14.7			
	40	13.1			13.5		14.0			16.0		13.0			14.5			13.0			14.7			
	50	11.6			12.5		12.5			15.5		12.9			14.3			13.0			14.7			
	60	10.5			12.2		11.2	11.3		14.2		12.7			14.3			13.0			14.5			
	70	8.4	8.8		11.8			10.0		12.5		11.8			14.2			12.8			14.5			
	80		7.6		10.2	8.5		8.7		10.0		10.2			12.2			11.8			13.5			
	90		6.0	6.2		7.8		7.3		8.3	9.0	8.3	9.1		10.0			10.5			12.7			
	100			5.7		6.9		5.5			8.2		8.3		7.8	9.1		8.5	9.1		10.5			
	110			4.3		6.0		4.2	4.8		7.3		7.3			8.8			8.9		8.3	9.1		
	120			3.8		5.3			4.0		6.7		6.2			7.6			7.9			9.1		
	130			2.2		4.5			3.5		5.8		5.4	5.6		6.9			6.9			8.8		
	140								3.0		4.8			5.3		6.2			6.0			8.2		
	150								2.4		4.1			4.8	5.4	5.6		5.2	5.6			7.3		
	160													4.3		5.5			5.4			6.5		
	170													3.6		5.0			4.9			5.7		
	180													3.0		4.7			4.3			5.6		
190															4.3			3.8			5.5			
200															3.8			3.3			5.3			
210															3.3						4.8			
220																					4.5			
230																					4.0			

NOTE: An offset of 50 feet will result in a decrease of about 25% from ratings as shown.

① Special turned (diameter) couplings are required on 2" packer systems, order no. 64655 in Jet and Sub price book.

NOTES



ITT
2881 East Bayard Street, Seneca Falls, NY 13148
Phone: (315) 568-7123 • Fax: (315) 568-7973
www.goulds.com

Goulds Pumps is a registered trademark of ITT Corporation. ITT, the Engineered Blocks Symbol and Engineered for Life are registered trademarks of ITT Manufacturing Enterprises, Inc.

Copyright © 2009 ITT Corporation BHSJ June, 2009 Printed in U.S.A.
SPECIFICATIONS ARE SUBJECT TO CHANGE WITHOUT NOTICE.

