



# ITT

BBF03S

## Residential Water Systems

# Goulds Pumps

## BF03S Shallow Well Jet Pump



### FEATURES

- **Self-Adjusting Capacity:** Automatically adjusts to the water demand within the pump's capacity.
- **Compact:** Can be easily installed in locations where other larger pumps are difficult to install.
- **Tankless:** Self-contained water system, no separate tank required.
- **Exclusive Air Handling Ability:** When pump is primed it never needs priming again even if the water level drops below the end of the suction pipe. It resumes pumping as soon as the water level rises again. Gas or air in the water will not air-bind the pump.
- **Protected Mechanical Seal:** Water is retained in the casing so the seal can never run dry.
- **Easy to Service:** Pump has nozzle clean-out plug. Provides easy access to nozzle and diffuser for cleaning. Back pull-out design - pipes do not have to be disturbed.
- **Powered for Continuous Operation:** Pump ratings are within the motor's working limits, can be operated continuously without damage.
- **Corrosion Resistant:** Electro-coat paint is applied inside and out, then baked on.



Goulds Pumps is a brand of ITT Corporation.

[www.goulds.com](http://www.goulds.com)

*Engineered for life*

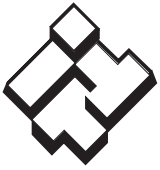

# ITT

## GOULDS PUMPS Residential Water Systems

### APPLICATIONS

Specifically designed for:

- Small homes
- Camps
- Mobile homes

### PUMP SPECIFICATIONS

- Pipe connections:  
 $\frac{3}{4}$ " suction,  
 $\frac{3}{4}$ " discharge
- Pressure switch: AS3 (20-40)

### MOTOR SPECIFICATIONS

- NEMA standard
- 115/230V, 60 Hz
- Single phase
- 3500 RPM
- Built-in overload with automatic reset.
- Capacitor start type
- Stainless steel shaft
- $\frac{1}{2}$  HP - see page 3 ①

### SYSTEM COMPONENTS

- **Basic Pump Unit:** Includes pump, motor, pressure switch, tubing and fittings, air volume control valve, suction check valve, nozzle and diffuser.

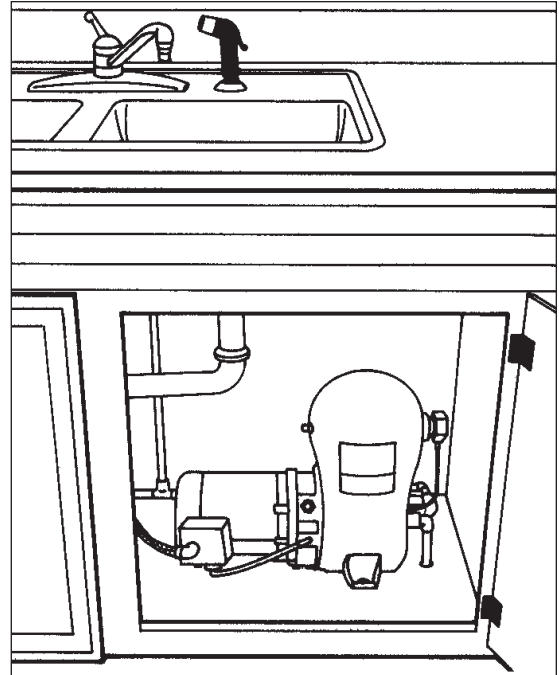

### DIMENSIONS AND WEIGHTS

(All dimensions in inches and weight in lbs.) (Do not use for construction purposes.)

HP/Model	① $\frac{1}{2}$ HP - BF03S
Weight	69
Length	20
Width	10 $\frac{1}{2}$
Height	15



# ITT

## GOULDS PUMPS Residential Water Systems

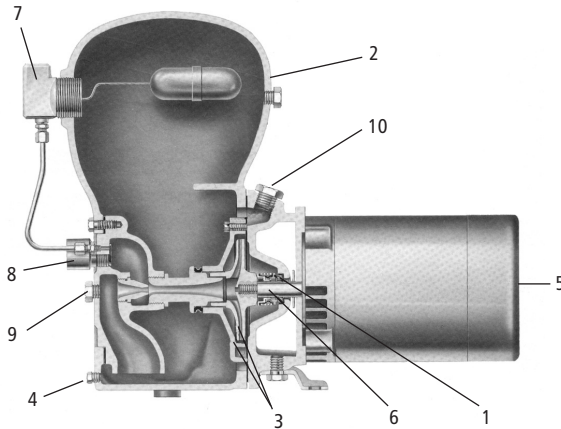

### COMPONENTS

1. Mechanical Seal
2. Casing
3. Impeller and Guide Vane
4. Drain Plug
5. Two-Compartment Motor
6. Stainless Steel Shaft
7. Air Volume Control
8. Check Valve
9. Nozzle Clean-Out Plug
10. Priming Plug

*Repair parts may be found in RJETPARTS book.*

### PERFORMANCE RATINGS

HP/Model	① 1/2 HP - BF03S		
Shallow Well Package	None Required		
Adapter	Built-In		
Nozzle	AN015		
Venturi (Diffuser)	4K5		
Total Suction Lift (Feet)	Discharge Pressure (PSI)		Maximum Shut-Off (PSI)
	20	30	
	Gallons Per Hour / GPM		
5	525 / 8.8	380 / 6.3	51
10	480 / 8.0	330 / 5.5	49
15	410 / 6.8	290 / 4.8	46
20	350 / 5.8	255 / 4.3	44
25	265 / 4.4	220 / 3.7	42

① Pump now uses a 1/2 HP motor due to 1/3 HP motors being obsolete.

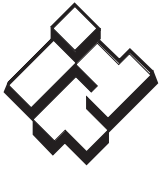

**ITT**

**Residential Water Systems**



Goulds Pumps and the ITT Engineered Blocks Symbol are registered trademarks and tradenames of ITT Corporation.

SPECIFICATIONS ARE SUBJECT TO CHANGE WITHOUT NOTICE.

**BBF03S June, 2008**

© 2008 ITT Corporation

*Engineered for life*