

# 1 HP CAST IRON CONVERTIBLE WELL JET PUMP

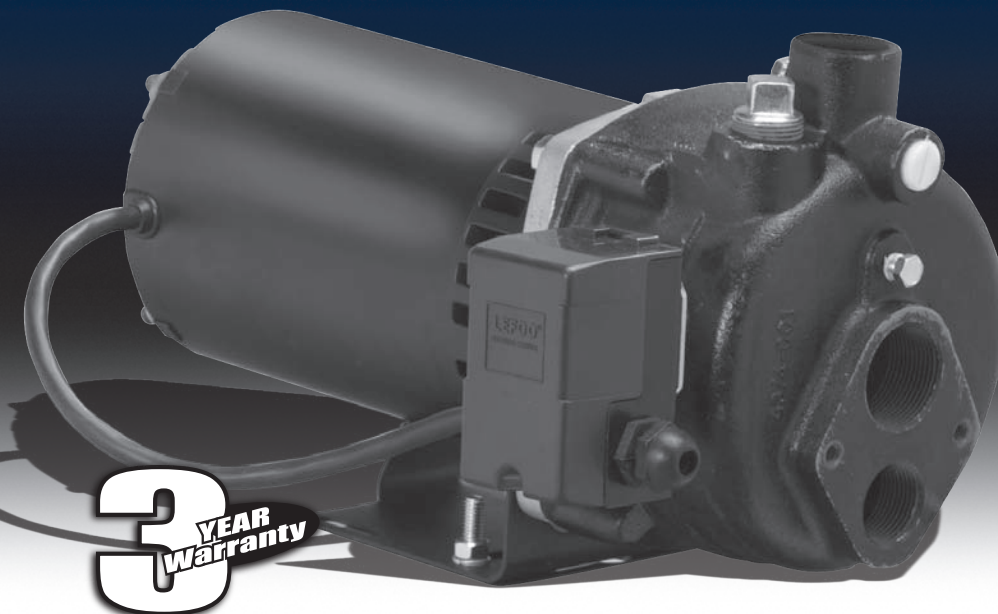

• **8.8 GPM @ 5' (50 PSI)**

- **Durable Cast Iron Volute**
- **Corrosion-Resistant, Reinforced Thermoplastic Impeller and Diffuser**
- **High Efficiency Square Flange Motor is Thermally Protected to Prevent Overheating and Universally Available if Replacement is Ever Required**
- **Pressure Switch Pre-Set at 30-50 PSI for Automatic Operation When Used With Water System Tank**
- **Dual Voltage (120/240), Factory Wired for 120 Volts**
- **Dedicated Priming Port for Convenient Volute Filling**
- **Brass Wear Ring**
- **3/4" NPT Discharge**
- **1 - 1/4" NPT Suction**
- **1" NPT Drive**
- **0' - 90' Well Depth**



**3**  
YEAR  
Warranty

[www.blueangelpumps.com](http://www.blueangelpumps.com)

# 1 HP CAST IRON CONVERTIBLE WELL JET PUMP



## CBS100

- 30/50 PSI Pressure Switch
- 120/240 Dual Voltage
- 3/4" NPT Discharge
- 1-1/4" Suction
- 0-90' Well Depth
- Shipping Weight, 40 lbs
- 3 Year Warranty

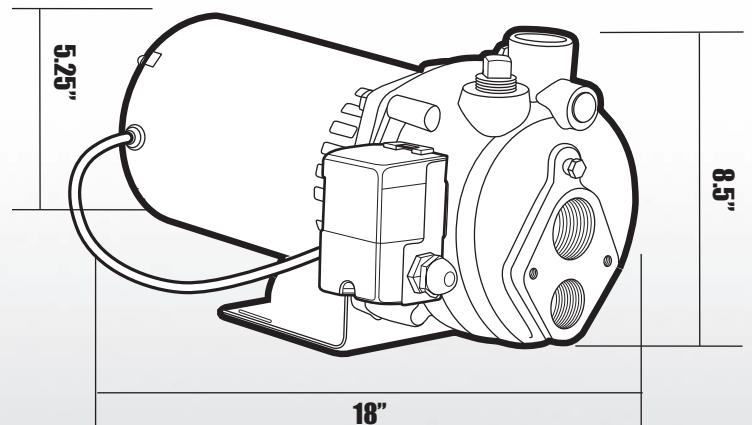

### MOTOR SPECIFICATIONS

MOTOR	RPM	VOLTS	AMPS	Hz
Split Phase	3450	120/240	13/6.5	60

### PERFORMANCE (GPM)

	WELL DEPTH												
	0'	5'	10'	15'	20'	25'	30'	40'	50'	60'	70'	80'	90'
30 PSI	17.6	16.7	15.8	15.0	14.1	13.5	12.5	10.7	8.6	6.4	4.9	3.9	3.0
40 PSI	14.0	13.5	12.5	11.6	10.7	9.8	8.8	6.4	4.9	3.9	3.0	2.1	1.2
50 PSI	9.8	8.8	7.4	6.4	5.5	4.9	4.4	3.9	3.0	2.1	1.2	-	-

REQUIRES APPROPRIATE JET ASSEMBLY  
 FOR PUMP AND SYSTEM ACCESSORIES SEE ACCESSORIES SECTION  
 BLUE ANGEL™ PUMPS • 101 Production Drive • Harrison, OH 45030 • 1-888-636-6628

© 2008 Blue Angel Pumps All Rights Reserved

