

# 2 HP CAST IRON PERMANENT LAWN SPRINKLING PUMP

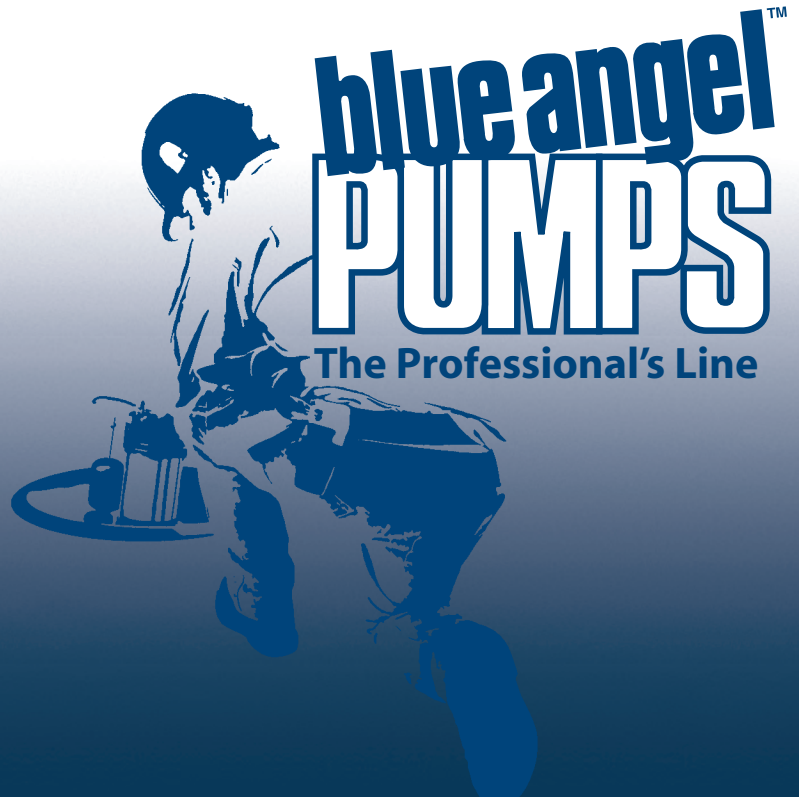

# blueangel<sup>™</sup> PUMPS

The Professional's Line

- **51 GPM @ 5' (40 PSI)**

- **Durable Cast Iron Volute**

- **Corrosion-Resistant, Reinforced Thermoplastic Impeller and Diffuser**

- **High Efficiency Square Flange Motor is Thermally Protected to Prevent Overheating and Universally Available If Replacement is Ever Required**

- **240 Volt Motor**

- **2" NPT Suction with 1-1/2" NPT Discharge**

- **Designed to Operate Underground Sprinkling Systems, Draw Water from Well, Lake or Ponds for Watering, Pool Filling or Any Other Applications Where High Water Volume is Needed**



**1** YEAR  
Warranty

[www.blueangelpumps.com](http://www.blueangelpumps.com)

# 2 HP CAST IRON PERMANENT LAWN SPRINKLING PUMP



## BWLS200

- Cast Iron Construction
- Suction Lift Up To 25'
- 118' Total Dynamic Head
- 240 Volt Motor
- 2" Suction
- 1-1/2" Discharge
- Shipping Weight, 60 lbs
- 1 Year Warranty

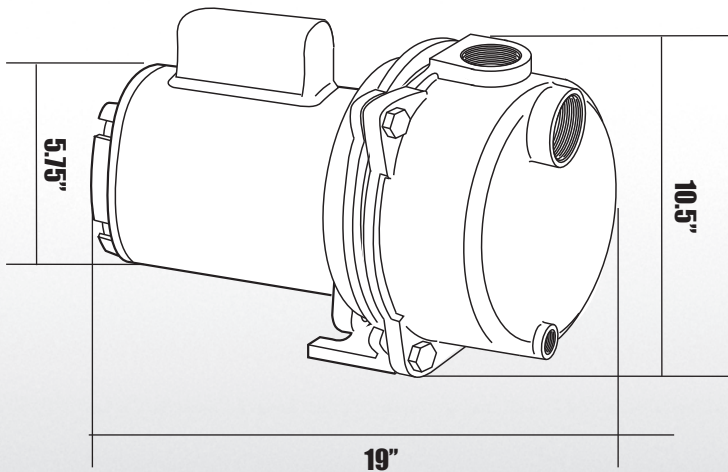

## MOTOR SPECIFICATIONS

MOTOR	RPM	VOLTS	AMPS	Hz
Split Phase	3450	240	11.5	60

## PERFORMANCE GPM

DISCHARGE PRESSURE	FLOW CAPACITY (GPM) SUCTION LIFT (FT)				
	5'	10'	15'	20'	25'
40 PSI	51	48	42.8	36.8	-
30 PSI	71.8	68.2	65	58.5	55
20 PSI	92.7	87	83	64	60
10 PSI	96.3	90.2	87.2	68.7	66.3

ACTUAL PERFORMANCE WILL BE AFFECTED BY INSTALLATION  
FOR PUMP AND SYSTEM ACCESSORIES SEE ACCESSORIES SECTION  
BLUE ANGEL™ PUMPS • 101 Production Drive • Harrison, OH 45030 • 1-888-636-6628

© 2008 Blue Angel Pumps All Rights Reserved

