

1.5 HP CAST IRON PERMANENT LAWN SPRINKLING PUMP

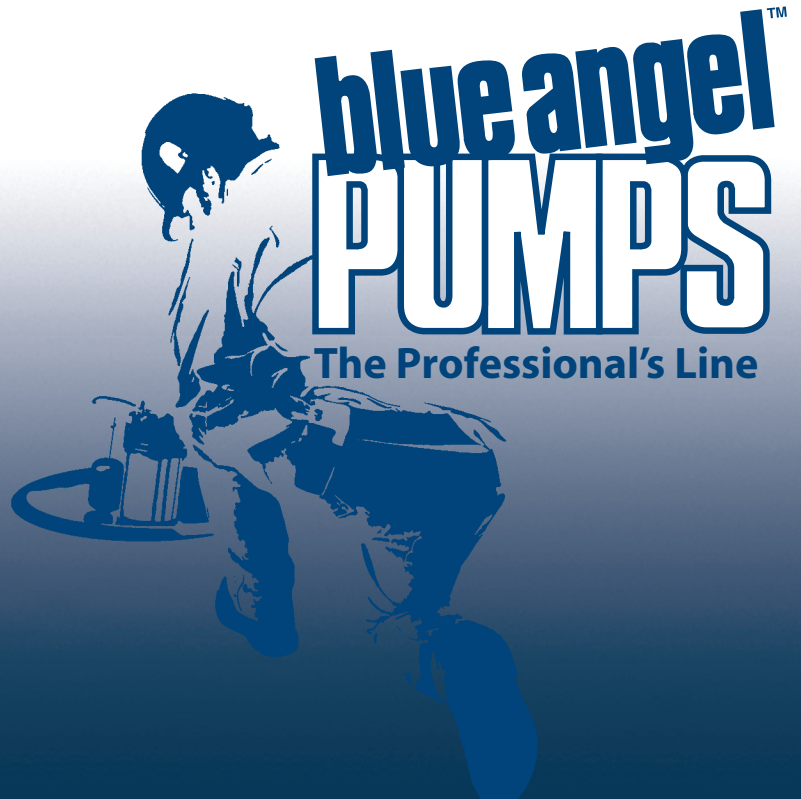

• **34.3 GPM @ 5' (40 PSI)**

• **Durable Cast Iron Volute**

• **Corrosion-Resistant, Reinforced Thermoplastic Impeller and Diffuser**

• **High Efficiency Square Flange Motor is Thermally Protected to Prevent Overheating and Universally Available If Replacement is Ever Required**

• **Dual Voltage Motor, Factory Wired for 240 Volts**

• **2" NPT Suction with 1-1/2" NPT Discharge**

• **Designed to Operate Underground Sprinkling Systems, Draw Water from Well, Lake or Ponds for Watering, Pool Filling or Any Other Applications Where High Water Volume is Needed**



1 YEAR
Warranty

www.blueangelpumps.com

1.5 HP CAST IRON PERMANENT LAWN SPRINKLING PUMP



BWLS150

- Cast Iron Construction
- Suction Lift Up To 25'
- 115' Total Dynamic Head
- Factory Wired for 240 Volts
- 2" Suction
- 1-1/2" Discharge
- Shipping Weight, 60 lbs
- 1 Year Warranty

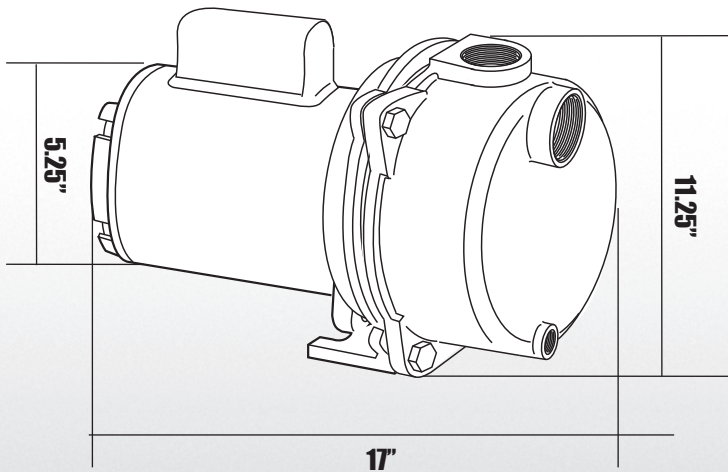

MOTOR SPECIFICATIONS

MOTOR	RPM	VOLTS	AMPS	Hz
Split Phase	3450	120/240	18.0/9.5	60

PERFORMANCE GPM

DISCHARGE PRESSURE	FLOW CAPACITY (GPM) SUCTION LIFT (FT)				
	5'	10'	15'	20'	25'
40 PSI	34.3	25.3	-	-	-
30 PSI	58	53.2	48.3	44.7	39.8
20 PSI	74.7	71.8	67.3	62	55
10 PSI	79.8	76.8	72	65	63.5

ACTUAL PERFORMANCE WILL BE AFFECTED BY INSTALLATION
FOR PUMP AND SYSTEM ACCESSORIES SEE ACCESSORIES SECTION
BLUE ANGEL™ PUMPS • 101 Production Drive • Harrison, OH 45030 • 1-888-636-6628

© 2008 Blue Angel Pumps All Rights Reserved

